



X Series

CPD10/15/18/20/25/30/35-XC4(-I)
CPD10/15/18/20/25/30/35-XD2(-I)
CPD40/45/50-XC4(-I) CPD20/25-XC4-JC(I)
CPD20-XXC4(-I) CPD25-XLC4(-I) CPD50-XXC4(-I)
CPD20-XXD24(-I) CPD25-XLD2(-I)

Electric Forklift Truck OPERATION AND MAINTENANCE MANUAL



Original Instruction

HANGCHA GROUP CO., LTD.

OM21-X01 (08 / 2021)

FOREWORD

Thanks for you purchasing our X series electric four-wheel forklift truck.

X series electric four-wheel forklift truck is our company's new product. It has the character of small turning radius, beautiful shape, small dimensions, low gravity, good stability, superior performance.

This operation manual is the explanations that how to use 1.0t~5.0t X series electric four-wheel forklift truck correctly. It will instruct you how to operate safety and precautionary maintenance. To ensure safety and exert the truck's potential, all the personnel that in charge of operation, maintenance and management must read this manual thoroughly before starting work with the forklift.

As the improvements of products of our company, maybe there are some differs between this operation manual with your forklift truck.

The company will continue to carry out equipment research and development, so the company reserves the right to modify the form, configuration and technology.

If you have any questions please keep touches with HANGCHA GROUP CO., LTD.sales department or let the agents know.

CONTENT

1.Specified purpose	1
General.....	1
Use as required	1
Allowed conditions of use	1
The obligations and responsibilities of the equipment user	2
Attachment installation	2
2.Introduce	1
Main components	1
Displays and Controls.....	2
Multi-function display	4
Controls	17
Seat	25
Safe belt	27
3.Nameplate and Safety Labels	29
4.Technical Specifications	31
5.Safety Instructions	54
6.Forklift Transport,Lifting & Towing	61
Transport	61
Lifting.....	61
Towing.....	62
7.The Structure and Stability of Truck	63
8.Running-in of the new truck	66
9.Daily Maintenance	67
10.Driving and Operation	73
Driving	73
Traveling.....	73
Turning	73
Stopping or parking	73
Loading.....	74
Stacking load.....	74
Un-stacking load.....	75
Check after operation	76
11.Deposit	77
12.Battery	78
13.Lithium battery	85
14.Maintenance summarization	97
Preventive maintenance schedule.....	99

Replace the key safe parts termly	106
Table for oil used in the truck	107
Table for bolts tightening torque	108
15.The use, Install and Safety Rules of attachment	109
Attachment assy	109
Attachment use	109
Check and maintenance:.....	110
16.Battery automatic filling water system(Optional)	111
17. Relevant safety command and standard (CE models).....	116

1. Specified purpose

General

Truck in this manual is only for lifting and transporting loads.

It must be used, operated and maintained according to the information in this manual. Any other uses are outside the design envelope and can lead to injury to persons or damage to equipment and property.

Use as required

The usable range of forklift trucks:

- Lift loads.
- Transport loads in short distance.
- It is forbidden to drive when the cargo is in the lifting state.
- Do not carry people.
- Do not push and pull loads.
- The cargo must be fixed on the trailer when the trailer is towed.
- Do not exceed the allowed trailer load.

Warning

- The maximum traction load is indicated on the model plate and must not exceed this value.
- The goods must rest on the back of the fork holder and in the middle of the fork.

Allowed conditions of use

Forklift use conditions:

- The allowable temperature range is between -20 ° C and 50 ° C.
- The allowable air humidity is no more than 90% (20 ° C).
- The allowable wind speed is no more than 12m/s.
- Use only on flat ground with sufficient carrying capacity.
- Use only on roads with a good view and approved by the equipment user.
- Max. uphill grade when driving without load is 25%.

- It is prohibited to travel crosswise or obliquely. When go uphill with loads, keep the forks forward; when go downhill, travel in reverse.

 **Warning**

- In extreme environments, especially when using the truck in an environment with severe dust or corrosion and rust, additional special equipment must be installed and approved by the manufacturer.
- It's prohibited to use this equipment in the anti-explosion area.
- Do not operate the truck outdoors or in hazardous areas in bad weather (storms, lightning strikes).

The obligations and responsibilities of the equipment user

In this operating instruction, "the user of the equipment" refers to any natural person or legal entity that directly uses or appoints others to use the forklift truck. In special circumstances such as leasing and renting, the "user of the equipment" represents the party who is obligated to perform the operational obligations based on the terms of the contract between the owner of the equipment and the user.

The user of the equipment must ensure that the forklift truck is only used for the intended purpose and removes the danger that may endanger the life and health of the user or the third party. In addition, equipment users must also strictly abide by the accident prevention regulations, other safety technical regulations, and guidelines for the operation, maintenance and repair of the equipment.

The truck can only be operated by personnel who have received special training. The user of the equipment must ensure that all operators carefully read and fully understand the contents of these operating instructions.

 **Caution**

- If you do not comply with the operating instructions, our company's warranty will automatically expire. Without the company's permission, if the customer and/or third party perform non-standard operations on the equipment, the company will not bear any responsibility for the resulting losses.

Attachment installation

The mounting or installation of any attachments which will interfere with, or supplement, the functions of the truck is permitted only after written approval by the manufacturer has been obtained. If necessary, the approval of local authorities has to be obtained. The results of the government department's review do not represent the opinions of the company.◦

2.Introduce

Main components



Item	Description
1	Fork
2	Load backrest
3	Mast
4	Rearview mirror
5	Overhead guard
6	Driver's seat
7	Counterweight cover
8	Counterweight
9	Towing pin
10	Rear wheel
11	Battery behind cover hood
12	Front wheel

Displays and Controls

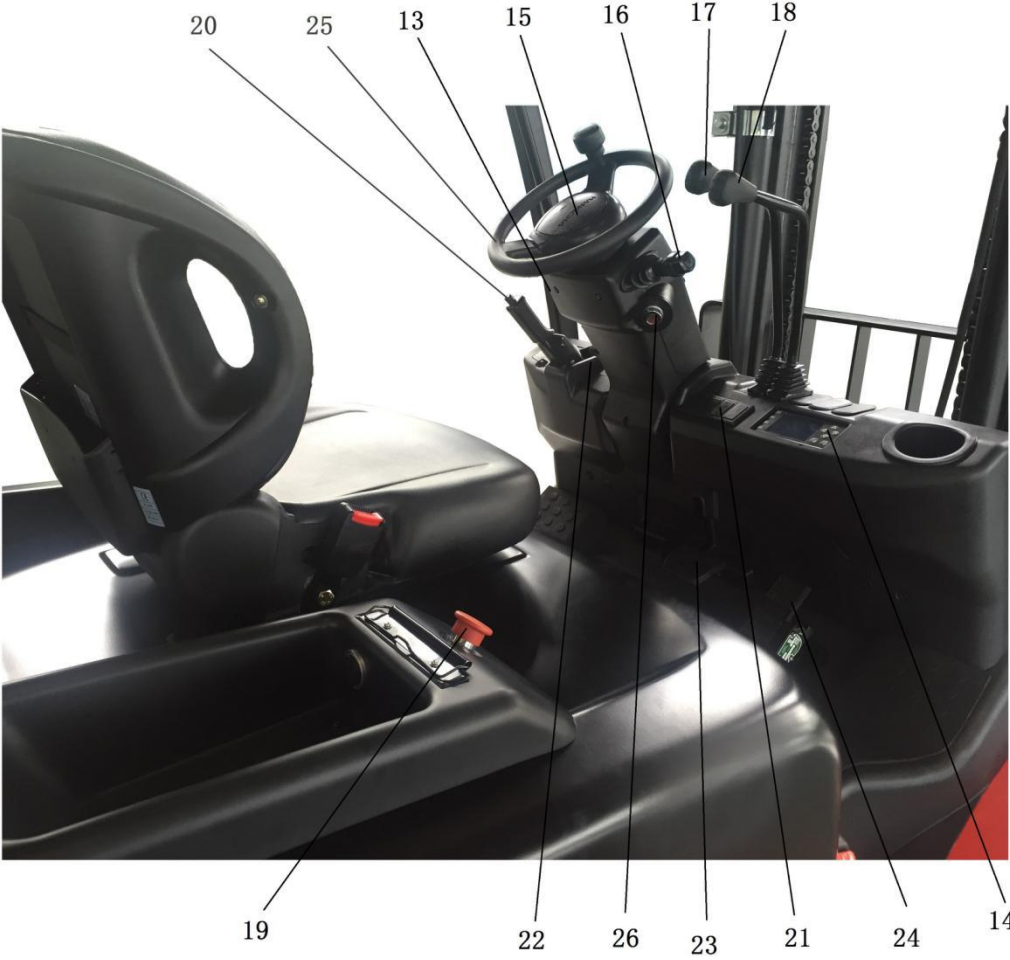

27



28



29



30

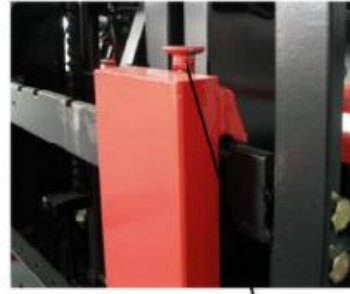



31



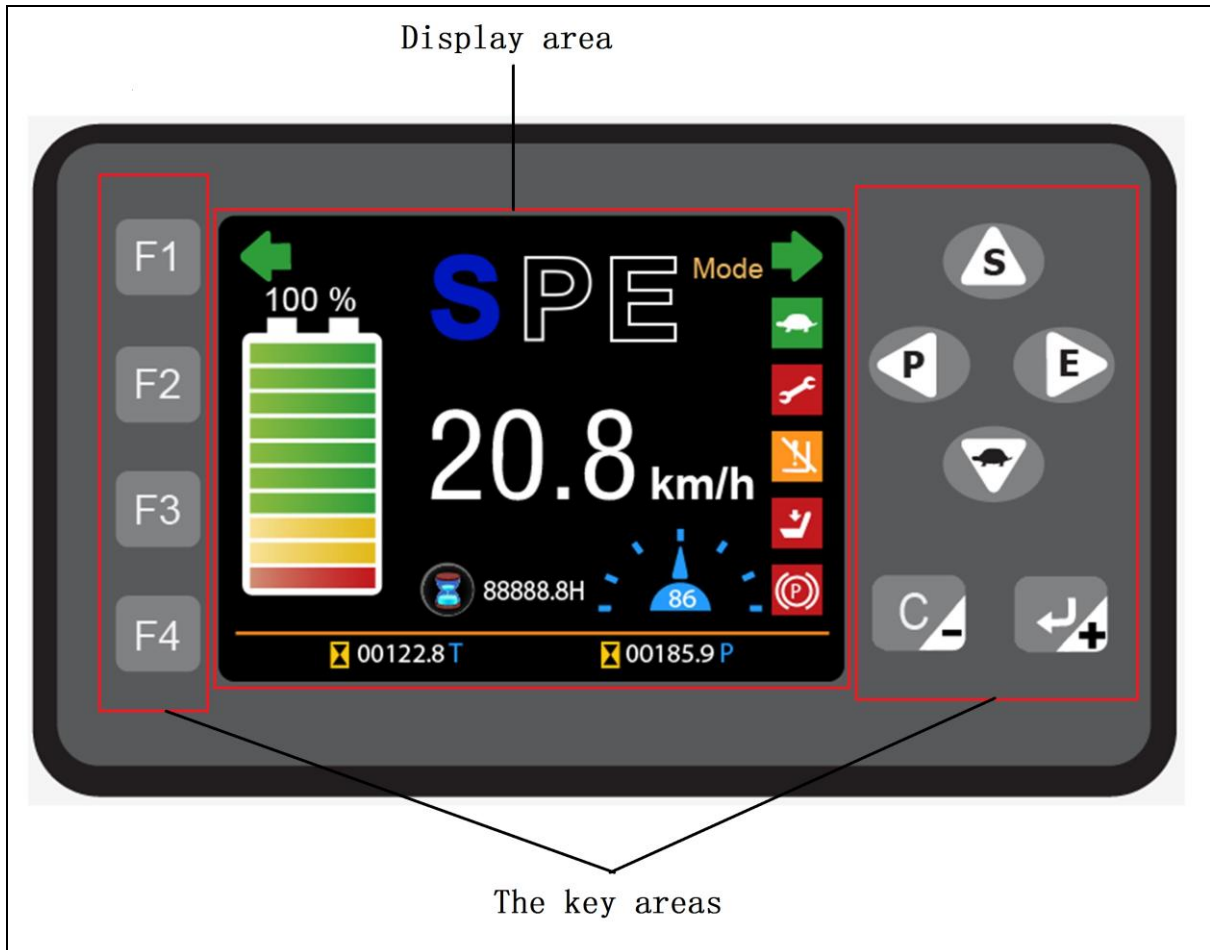

Item	Control / Display
13	Travel direction switch
14	Multi-function display
15	Horn
16	Combination light switch
17	Lifting lever
18	Tilting lever
19	Emergency disconnect switch
20	Hand brake (non -E series forklift truck)
21	Warning light switch
22	Steering column positioning device
23	Brake pedal
24	Accelerator pedal
25	Steering wheel
26	Key switch
27	Locker of battery cover hood
28	Side door lock
29	Air spring
30	Fuse box
31	Fork stopper

Multi-function display

The multi-function display shows the battery capacity, the service hours, the operating mode, the travel speed and fault code information. Graphic illustrations on the multi-function display act as warning indicators. Through the multi-function display on the right button can also check fault code and parameter setting.



F1	Enter/exit the operation menu; when the meter is in the password input interface, press F1 to enter the number "1".
F2	Enter/exit the meter menu; when the meter is in the password input interface, press F2 to enter the number "2".
F3	Enter/exit the controller menu; when the meter is in the password input interface, press F3 to enter the number "3".
F4	Enter/exit the controller menu; when the meter is in the password input interface, press F4 to enter the number "4". When the meter is in the menu interface and the menu option is a modifiable parameter, press F4 to adjust the parameter change. The step size can be set to change the single digit, tens, hundred or thousand digits of the parameter.
	The setting mode is super mode; when the meter is in the password interface, press ▲ to switch the user password or OEM password input setting; when the meter is in the menu interface, press ▲ to move the menu option up.

	<p>The setting mode is slow mode; when the meter is in the password interface, press ▼ to switch the user password or OEM password input setting; when the meter is in the menu interface, press ▼ to move the menu option down.</p>
	<p>The setting mode is power mode; when the meter is in the password interface, press the key to switch the user password or OEM password input setting; when the meter is in the menu interface, press the key to return to the previous menu.</p>
	<p>The setting mode is economic mode; when the meter is in the password interface, press the key to switch the user password or OEM password input setting; when the meter is in the menu interface, press the key to enter the next level menu.</p>
	<p>When the meter is in the password interface, it is used to delete the entered password; when the meter is in the menu interface, it is used to reduce the parameter setting value or return to the previous menu.</p>
	<p>Enter the fault interface; when the meter is in the password interface, it is used to check the input password; when the meter is in the menu interface, it is used to increase the parameter setting value or enter the next level menu.</p>

Main display interface

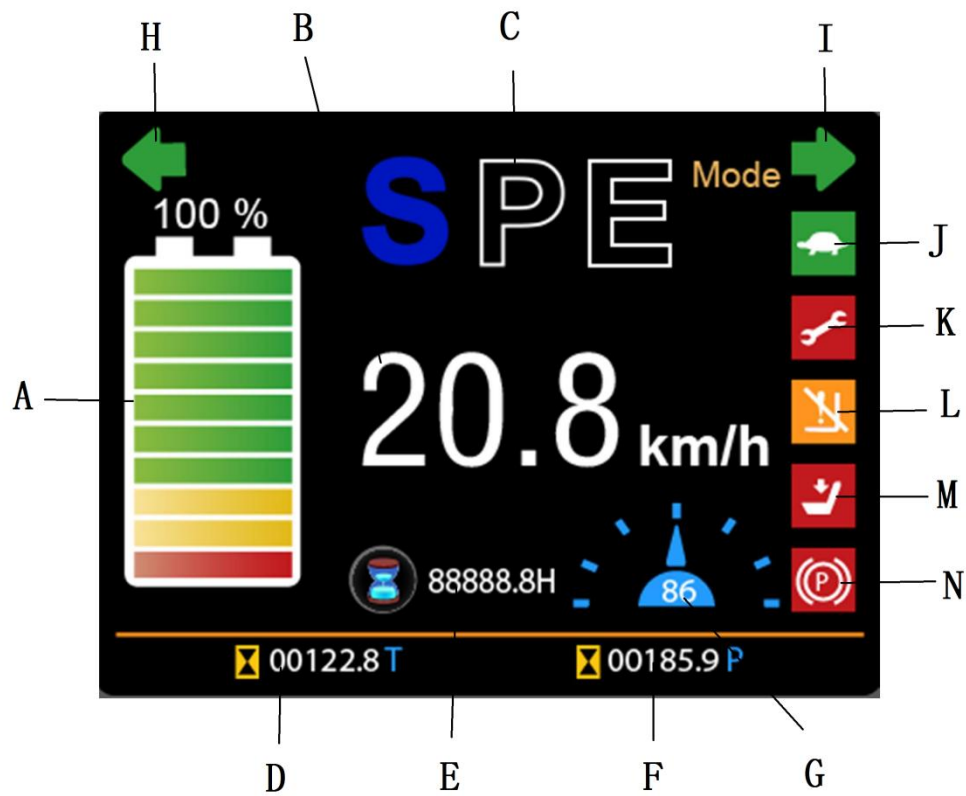

A	Battery level display	H	Left turn indication
B	Travel speed display	I	Right turn indication
C	Operating mode display	J	Turtle speed mode indication
D	Traction controller running hours display	K	Fault repair indication
E	Vehicle running hours display	L	Battery below 10%, lift lock indication
F	Pump controller operating hours display	M	Seat indication
G	Vehicle steering angle display	N	Park indication

Battery level display [A]



Shows the remaining capacity of the battery.

As shown in the above figure, when the battery power is less than 20%, the entire battery indicator will flash. At this time, please stop working and charge immediately. It is recommended to charge when two grids remain (the remaining battery is about 30%), otherwise the battery life will be greatly shortened.



CAUTION

- **Charging in time is very important, otherwise it will affect the lift-span of battery!**

Travel speed display [B]

20.8 km/h

Normal work, display the truck travel speed.

Operating mode display [C]



As the diagram shows

S mode is super mode, thus the truck's acceleration, deceleration rate, max climbing gradient and so on is much higher. It is applied for transporting mass of good in short time and climbing big gradient slop, but it costs more energy, so the mode will not be used in normal state except emergency.

P mode is power mode. All kinds of index are lower than that of super mode. It is applied for the case of long distance transporting and needing higher power or speed.

E mode is economical mode. All the parameters are optimized. Working in this mode can save power so it is applied for a long time work after charging, and it is suggested to work in this mode in normal work-time.

SPE mode: The truck is in Safety Mode. In this mode, maximum traveling speed is limited to 7km/h. it is very good for working in a crowd warehouse or other compact space. In this mode, the slow indicator[F]  will be on.



CAUTION

- **The default mode is mode E. after power cutting every time, the work mode resets to mode E no matter which mode it is before power cutting, but the switch key is still in the mode before turn off.**

Traction controller running hours display [D]

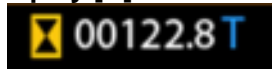

The hourglass icon indicates the hour meter function.
Display the cumulative working time of the traction controller

Vehicle running hours display [E]

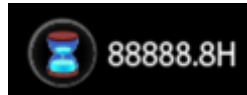

The hourglass icon indicates the hour meter function.
When the vehicle key switch is turned on, the hour meter starts counting, and the minimum resolution is 0.1 hour.

Pump controller operating hours display [F]

The hourglass icon indicates the hour meter function.
Display pump controller cumulative working time.

Vehicle steering angle display [G]



Steering wheel (rear wheel) steering angle and steering direction display.
As the steering wheel turns, the centered arrow symbol rotates around the center of the circle.
1. Steering direction display: the arrow is turned to the left around the center of the circle, then it is turned left; when it is deflected to the right, it is turned right.
2. Steering angle display: The larger the deflection angle, the larger the turning angle.

Left turn indication [H]



When the vehicle turns left, turn on the left turn signal and the indicator lights up.

Right turn indication [I]



When the vehicle turns right, turn on the right turn signal and the indicator lights up.

Crawl speed indicator [J]



When the truck in SPE mode, the crawl speed indicator light up.

Fault indicator [K]



The light up when the controller is wrong or operation mistake, and the fault code shows in the main display screen.

Lifting low speed indicator [L]



When there is 10% power, the indicator is on, and the mast lifting speed drops, to remind user to charge the battery as soon as possible.

Seat switch indicator[M]

When operator leaves the seat, the light will be on, and the truck will be unable to travel or lift. This function needs the seat to equip with seat switch.

Parking brake applied indicator[K]



When parking brake applied, the light up.

Battery low capacity indicator



This indicator lights up when the power is less than 20%.

Menu password interface

When the meter is in the main interface, press F2 or F3, the meter will enter the password interface before entering the corresponding meter or controller menu. Only when the user inputs the correct password, the meter will enter the corresponding menu interface. The password interface is displayed as follows:

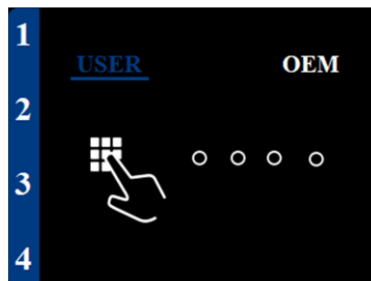









OEM password

The meter sets menu options at different permission levels for the users. As shown in the figure above, when “User Password/USER” is selected and the corresponding user password is entered, the meter enters the user level menu; after “OEM password/ OEM is selected, enter the corresponding OEM password, the meter enters the OEM level menu. If the password is entered incorrectly, the meter will prompt the password error and you need to re-enter the correct password.

Password interface button function

When the meter is in the password input interface, the function of each button is as follows:

F1	Enter the number "1" for the password.
F2	Enter the number "2" for the password.
F3	Enter the number "3" for the password.
F4	Enter the number "4" for the password.
	Switch user password/OEM password.
	Switch user password/OEM password.
	Switch user password/OEM password.
	Switch user password/OEM password.
	Delete the entered password; if the password has been deleted, press the C/- button to return the meter to the main interface.
	When the 4-digit password is all entered, press  and the meter will automatically verify that the password is entered correctly. If the password is correct, the meter enters the corresponding menu. If the password is entered incorrectly, the meter prompts the password error. Note: When the password input is less than 4 digits,  is invalid pressed.

Fault interface



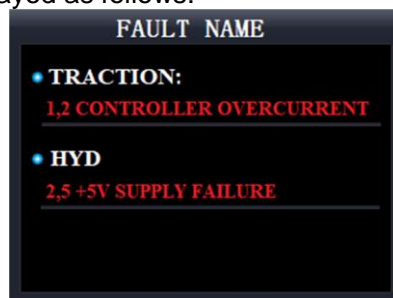



When the meter is in the main interface, press /+ to enter the fault interface. The fault code and the corresponding fault name are displayed according to the currently received controller fault code. The fault interface is displayed as follows:



When the meter is in the fault interface, press  again and the meter will return to the main interface display.

Key function

When the meter is in the main interface, you can enter the following 4 menu interfaces by pressing F1~F4.

F1	Enter/exit the operation menu.
F2	Enter/exit the meter menu.
F3	Enter/exit the controller menu.
F4	Enter/exit the controller monitoring menu; when the meter is in the meter menu or controller menu interface, if the current menu option is a modifiable parameter, press F4 to adjust the parameter change step size to set the single digit, tens, hundreds, or kilobyte value of the parameter separately.
	Move the menu option up.
	Move the menu option down.
	Return to the previous menu.
	Enter the next level menu.
	When the current menu option is a modifiable parameter, it is used to reduce the parameter setting value, otherwise it will be returned to the previous menu.
	When the current menu option is a modifiable parameter, it is used to increase the parameter setting value, otherwise it will enter the next level menu.

The multi-function display shows the battery capacity, the service hours, the operating mode, the travel speed and fault code information. Graphic illustrations on the multi-function display act as warning indicators. Through the multi-function display on the right button can also check fault code and parameter setting.

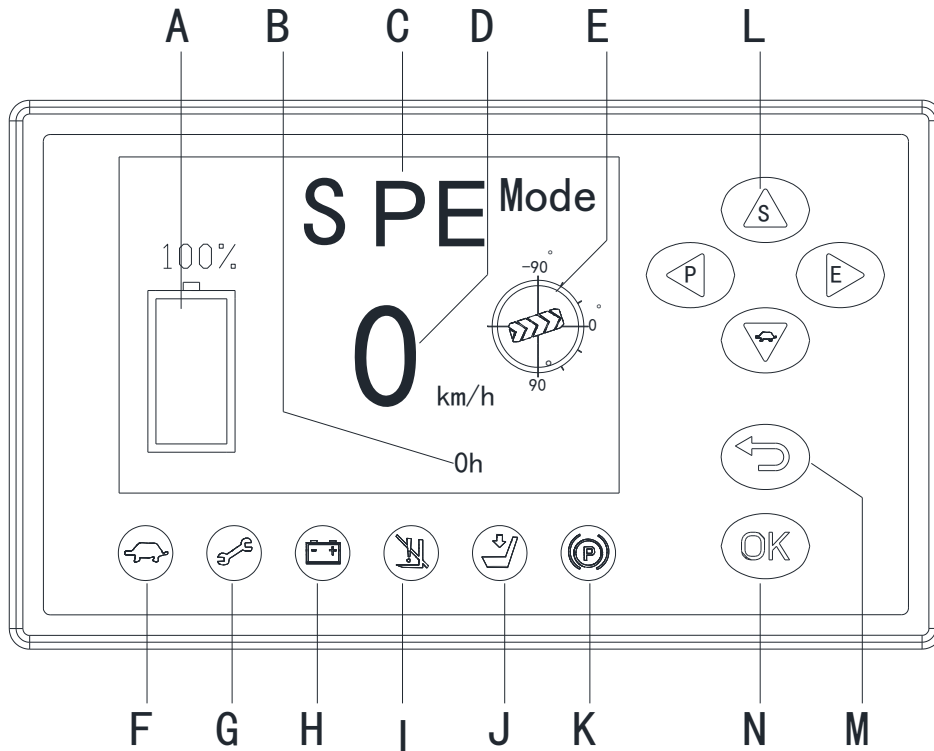

Item	Display	Item	Display
A	Battery capacity display	H	Battery low capacity indicator
B	Service hours display	I	Lifting low speed indicator
C	Operating mode display	J	Safety switch indicator
D	Travel speed or fault code display	K	Parking brake applied indicator
E	Steering wheel angle display	L	Mode settings or direction choosing button
F	Crawl speed indicator	M	return key
G	Fault indicator	N	Menu key

Main display interface



Battery capacity display[A]

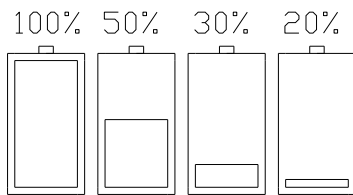

Indicates the available residual capacity.

As the following diagram shows, from the left to the right, the battery decreases from full state to the only one case, which represents that the battery leaves only 20%. Thus the whole battery indicator bar will twinkle, and the state indicator lamp will be bright, now please stop working and charge immediately.

 **CAUTION**

- **Charging in time is very important, otherwise it will affect the lift-span of battery!**

Service hours display[B]

0h

Hourglass icon indicates that timing function.

When you turn off the key switch, the hour meter will work and the minimum unit is 0.1

hour.

Operating mode display[C]

S P E S P E S P E S P E

As the diagram shows, the pictures from the left to the right represent the mode of **S** mode → **P** mode → **E** mode → **SPE** mode.

S mode is super mode, thus the truck's acceleration, deceleration rate, max climbing gradient and so on is much higher. It is applied for transporting mass of good in short time and climbing big gradient slope, but it costs more energy, so the mode will not be used in normal state except emergency.

P mode is power mode. All kinds of index are lower than that of super mode. It is applied for the case of long distance transporting and needing higher power or speed.

E mode is economical mode. All the parameters are optimized. Working in this mode can save power so it is applied for a long time work after charging, and it is suggested to work in this mode in normal work-time.

SPE mode: The truck is in Safety Mode. In this mode, maximum traveling speed is limited to 7km/h. it is very good for working in a crowd warehouse or other compact space. In this mode, the slow indicator[F]  will be on.

 **CAUTION**

- **The default mode is mode E. after**

power cutting every time, the work mode resets to mode E no matter which mode it is before power cutting, but the switch key is still in the mode before turn off.

Travel speed or fault code display[D]

Travel speed display



Normal work, display the truck travel speed.

Fault code display

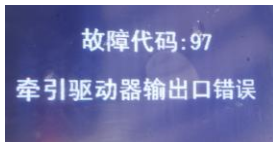

Failure occurs, display the controller's fault code.

Indicator light



Crawl speed indicator[F](Green)



When the truck in SPE mode, the crawl speed indicator light up.

Fault indicator[G](Red)



The light up when the controller is wrong or operation mistake, and the fault code shows in the main display screen.

Battery low capacity indicator[H](Red)



When there is only one line for the power, the indicator will be on to remind the user to charge the battery.

Lifting low speed indicator[I](Red)



When there is 10% power, the indicator is on, and the mast lifting speed drops, to remind user to charge the battery as soon as possible.

Seat switch indicator[J](Red)



When operator leaves the seat, the light will be on, and the truck will be unable to travel or lift. This function needs the seat to equip with seat switch (optional).

Parking brake applied indicator[K]





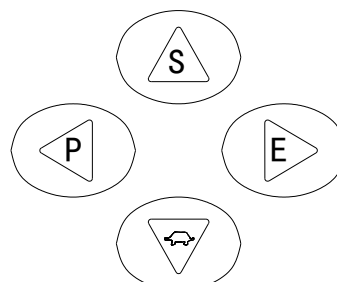

When parking brake applied, the light up.

Button

Mode settings or direction choosing button[L]





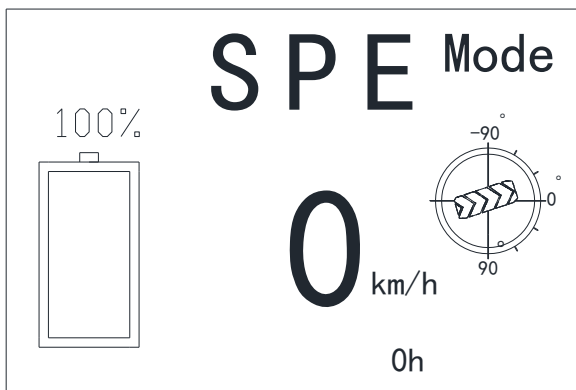

Mode settings

In the main display interface, the button , , , , corresponding **S** mode, **P** mode, **E** mode, **SPE** mode.

For example: In the main display interface, press the button , the screen shows as follows:



Direction choosing

In the menu interface, the button , , , , corresponding up, left, right, down four direction choosing button keys.

Menu button[M]

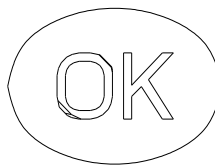

(1) In the main interface, press the menu key [M], enter the password, and then press the menu key to enter the main menu page.





(2) **Language switch setting:** This instrument supports two languages, Chinese and English, which will be adjusted to the language you need when leaving the factory. If you need to switch the language, please refer to the following example for operation.

For example: The language from English switch to Chinese.



① On the main page, press the menu key () to enter the main menu. The main menu display is as follows:

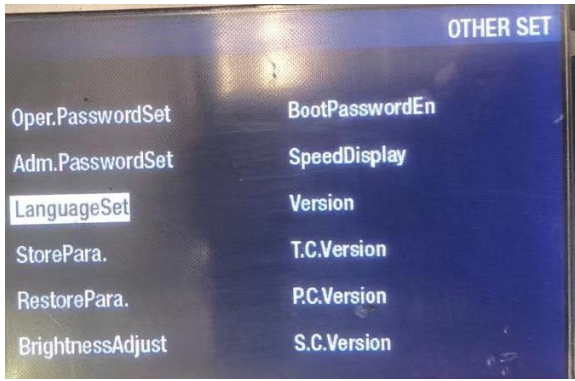

② Use the up key () or down key () to select "other settings".

③ Press the menu key () to enter other setting menus.



⑥ Use the up key () or down key () to select the Chinese language.

⑦ Refer to steps ⑤ ④ ③ ② ①, press the return key () to return to the main interface.

④ Select the "Language" option by moving up

() or down ().

Press the menu key () to enter the language setting state.

Controls

Rearview mirror [4]

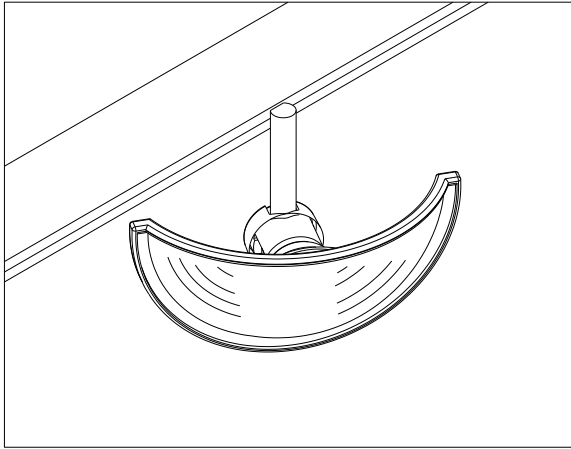

Used for observing rear condition or back up. Adjust rearview mirror before operating forklift, and make sure the rearview mirror vision in the best position.

Travel direction switch [13]

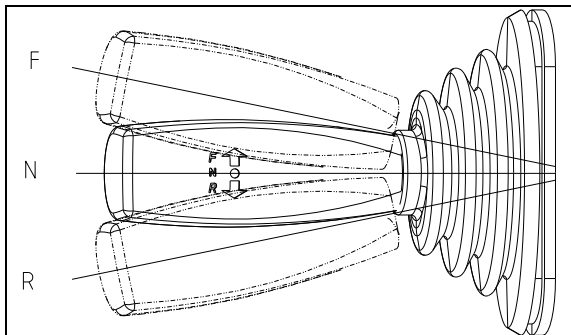

Sets the required travel direction.

The travel direction switch is used for switching between forward and backward moves. When the travel direction switch is pushed forward and accelerator pedal pressed, the forklift trucks moved forward. When the travel direction switch is pushed backward, the forklift trucks moved backward.

! CAUTION

- While traveling, if change the travel direction switch, electric braking will operate, speed will lower until

stop, then travel to the opposite direction.

! WARNING

- Turning the key switch “on” does not make the forklift truck move, if the travel direction switch is not in the neutral position or the accelerator pedal is being pressed. In this case, the travel direction switch should be returned to neutral and move you foot from the accelerator pedal. Then the truck can be operated.

Combined light switch [16]

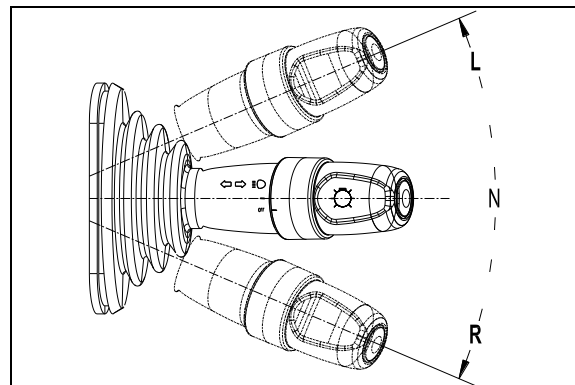

Control the turn signal lights, headlights and front small lights working condition.

This combined light switch is composed of turning light switch and big/small lamp switch. Turning light indicates the traveling direction. When turn on the switch, the lamp flashes. The light switch has two shifts. First shift small lights on; second shift headlights and small lights both up.

Forward	Left turning lamp flashes
Neutral	Lamp goes off
Backward	Right turning lamp flashes

! CAUTION

- The turn signal switch does not automatically return to the neutral position. Reset it by your hand.

Lifting lever [17]

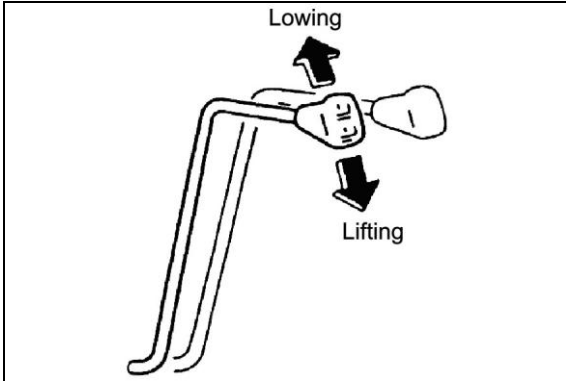

Lifts / lowers the forks.

The forks can be raised or fell by pulling backwards or pushing the lever. Lifting speed can be controlled by tilt backwards angle of lever and the lowering speed can be controlled by tilt forwards angle of the lever.

Tilting lever [18]

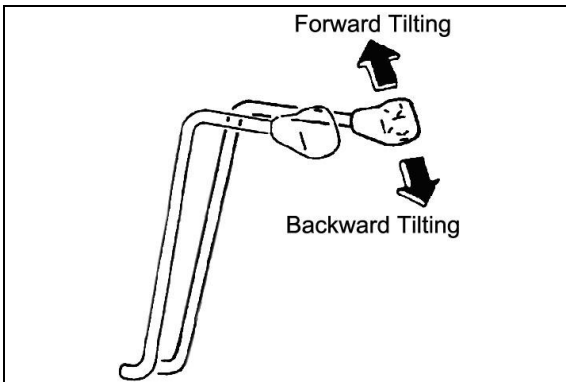

Tilts the forks forward / backward.

The forks can be tilted by operation of this tilt lever. Pulling on this lever backwards will tilt the forks backwards, and pushing it forwards will tilt the forks forwards. The tilt speed can be controlled by tilt angle of the lever.

! CAUTION

- The tilt lock mechanism built in the hydraulic control valve does not allow the mast to tilt forwards while

the electricity is being shut down even if the tilt lever is pushed forwards.

Emergency disconnect switch [19]

Switches power supply on and off.

When happen emergency, presses down the emergency disconnect switch, and then the main power of the truck will be cut off, the truck stops working.

! CAUTION

- Please don't use the emergency disconnect switch to substitute the function of key switch.

Hand brake [20](1.0t~3.5t non -E series forklift truck)

Secures the truck when stationary.

Use this parking brake lever to park the lift truck. And the parking brakes are applied on the front two wheels by pulling up on this lever. To release the parking brakes, move the lever forwards.

There is a micro switch at the left side of the parking brake lever, tense the lever makes running invalid.

For the truck of CE: if you leave the seat without tensing the lever, it will warn and remind you to tense the lever.

! WARNING

- If parking on a grade is unavoidable, be sure to block the wheel.

Parking brake switch(1.0t~3.5t For -E series forklift truck, 4.0t~5.0t)

Secures the truck when stationary.

Automatic start parking brake switch after power off. When the operator leaves the seat, press the parking brake switch to manually

start the parking brake.

Steering column positioning device [22]

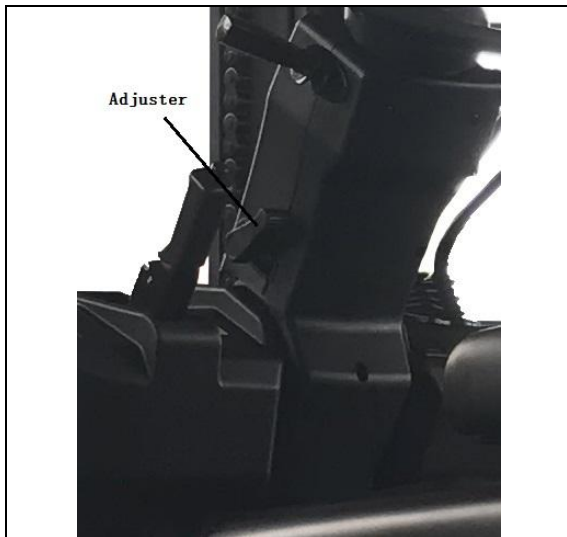

Adjusts and fixes the steering column to the required distance.

The tilting angle of the steering column is adjustable to suit individual operators. Turn the hand lever upward to release the steering column and locked by turning it downward.

Brake pedal [23]

Decelerates the truck.

Press this pedal to slow or stop the truck. At the same time, the brake light comes on.



CAUTION

- No permitted to press the brake pedal and the accelerator pedal at same time, otherwise, it is harmful to the traveling motor.

Accelerator pedal [24]

Provides infinitely variable control travel speed.

As the accelerator pedal is slowly pressed, the drive motor start turning and the forklift truck will start to move. According to the force applied to the pedal, the speed is adjusted with not steps.



CAUTION

- Loosen the accelerator pedal when truck is working, truck can make soft brake.



WARNING

- Before open the key switch to press the accelerator pedal, the more function digital indicator shall show alarm information. Then you must release the accelerator pedal.

Steering wheel [25]

It's can control the forklift steering.

The steering hand-wheel is operated in the conventional manner, that is, when the wheel is turn right, the truck will turn to the right; when the wheel is turn left, the truck will turn to the left. The steer wheels are located at the rear of the truck. These cause the rear of the truck to swing out when a turn is made.



WARNING

- This truck is provided with the power steering, so heavy hand-wheel operation is caused when the steering motor comes to a stall. To put the power steering in operation again, restart the steering motor without delay.

Key switch [26]

Switches control current on and off. Removing the key prevents the truck from being switched on by unauthorised personnel.

The key switch has two "on/ off" position, you should push the Direction switch lever to neutral and loose the accelerator pedal, then turning the key switch to "on" position clockwise.

! CAUTION

- Turning the key switch “on” does not make the forklift truck move, if the Direction switch lever is not in the neutral position or the accelerator pedal is pushing.
- Error code maybe appear, don't worry about it.
- The Direction switch lever should be returned to neutral and move you foot from the accelerator pedal. Then the truck can be operated.
- Then the error code should be disappeared.

Locker of battery cover hood [27]

Fixed the battery cover.

Side door lock [28]

Locking the side plates on both of the battery box.

Air spring of battery cover [29]

When the battery cover hood opened, to support the cover hood. When closed the cover hood, press the red button, at the same time hard to press the cover hood.

Fuse box [30]

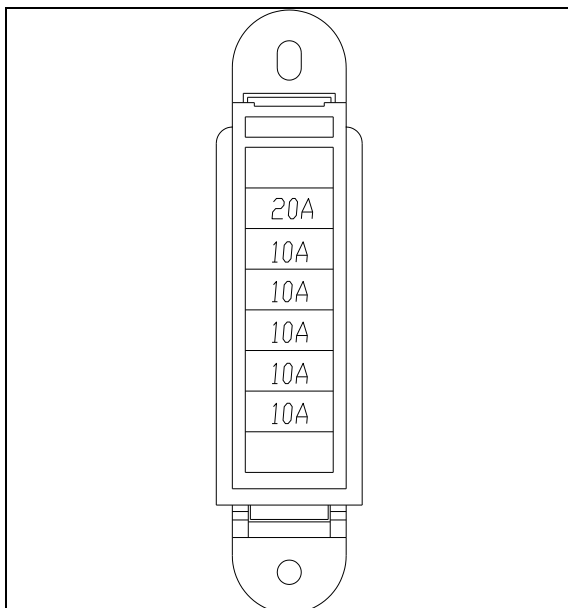

! CAUTION

- When replace a new fuse, please choose the same capacity fuse of the old one.

Fork stopper [31]



Fork stoppers are locked the forks in position. To adjust fork spacing, pull up fork stoppers, turn 90° and shift the forks to the desired position. The fork spacing should be adjusting according to loads to be handled.

! WARNING

- The forks should be set symmetrically to machine centerline and fork stoppers should always be locked again.
- There are one gap on the below beam. It is used to attach goods.
- It is forbidden to lock the fork on the gap position, to prevent the fork fall off from the gap.
- In the middle of the above beam, a bolt used to prevent fork works here. Please change the bolt as soon as it is damaged.

Change fork

Take down the old fork: Firstly, locate the fork to the middle, decline it to the ground and make the mast forward, then operate the truck traveling backward, the fork will be taken

down.

Change new fork: Firstly, make the fork dead against the truck and forklift's mast to the bottom, then operate the truck traveling forward, aim at the two gaps and beams, and raise the mast. Adjust the position of the fork.

Battery cover hood

The cover hood can be swung up fully to provide easy examining and maintenance of the storage batteries.

You can lift up the cover hood with little effort with an aid of cover hood damper. To lock the cover hood, push down on the front of cover hood until it covered.

 **CAUTION**

- **Be careful do not to catch you fingers in the cover hood when closing it.**
- **Depress the spring insurance before you close the cover hood, then press the head of the cover hood.**

Overhead guard

The overhead guard used is strong enough to meet safety standard, and protects the operator from falling materials. The top gap is used to lift the batteries. It is forbidden for use a truck that does not with safeguard.

L.H. & R.H. battery side plate

The battery is covered hood, one left and one right. When you want to take off the hood, you should take off the locking bolts at first.

Safety step and safety grip

The safely steps are provided on both side of the truck body. The safely grip is provided on the front left pillar of the overhead guard. Use the safely step and safely grip when mounting and dismounting the truck.

Brake fluid reservoir cup

The brake fluid reservoir cup is located at the meter board.

 **CAUTION**

- **The brake fluid is poisonous, be careful do not drop down. When add brake fluid, be careful do not let dirt and other thing drop into reservoir cup.**

Hydraulic oil reservoir cap

The hydraulic oil reservoir cap is located at the right rear end, below the battery hood; open the right side battery hood when adding oil. After fill in clean hydraulic fluid, tighten lock the cap.

Air leakage plug

There is an air leakage plug on the oil tank to let air in the tank goes out. You'd better often check the plug and see whether been jammed.

Head lights and combination lights

Two headlights and combination lights (turn signal, show width lamp) are installed at the front side of the truck. Take care of the lights, and wipe dirt, if any, and replace any damaged light immediately.

Rear combination lights

The combination lights at the rear side serve as turn signal, show width lamp, brake lamp, and back-up lamp. Pay attention to keep them from being damaged or covered with dust, if any, clean or replace immediately.

Rear big lamp [For CE or Option]

The rear big lamp is set on the safeguard. If it is broken, please replace a new one at once.

Rear big lamp switch [optional]

Rear big lamp switch (push\pull) has only one shift.

x—Means connected

Position \ Connector	Battery	Far light
0	x	
1	x	x



CAUTION

- This light does not relate to key switch position, so please don't forget to turn off the rear big lamp when you leave the truck.

;

Fingertip operation (option)

Armrest system is composed of armrest bracket, fingertip, emergency stop button, horn button and wire etc.

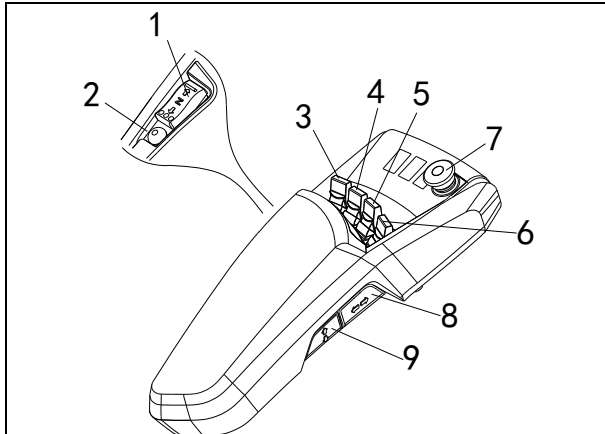

1.Direction switch	2.Horn button	3.Lift finger tip
4.Tilt fingertip	5.Sideshifter fingertip	6.Attachment fingertip
7. Emergency stop button	8.Level shift handle	9.Vertical shift handle

Direction switch

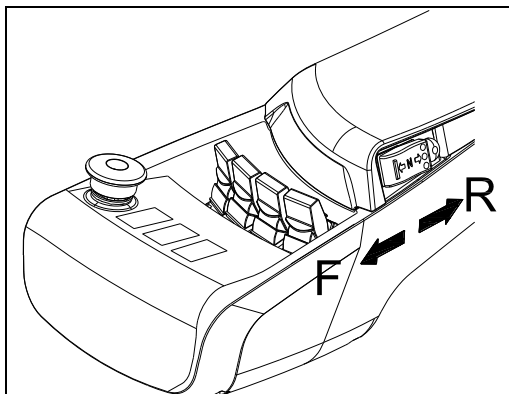

Set forklift direction according to need. Direction switch is used to switch the forklift going forward or backward. Press the switch forward and step on the accelerator pedal, forklift travels forward; press the switch backward, forklift travels back.



Caution

- If press the direction switch to opposite direction during truck running, the electric braking works to decelerate the forklift. After stop, the truck moves to another direction.
- If the direction lever is not in neutral, when the key switch is turned to ON, a fault code will be displayed. Return the direction lever to the neutral position, the fault code will then disappear.

Lift fingertip

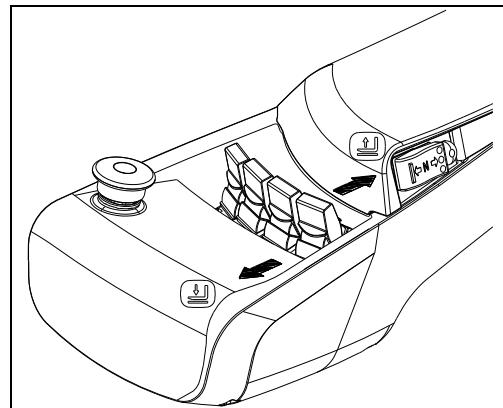

Push the fingertip forward to lower the forks. Pull the fingertip back to raise the forks. The lifting lowering speed is controlled by the tilting angle that the lever is moved, the larger angle, the faster speed.

Tilt fingertip

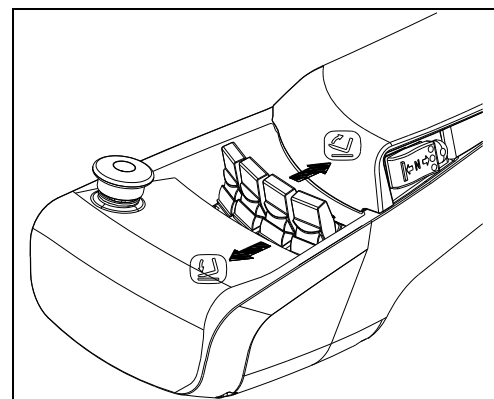

Push forward the fingertip to tilt the forks forward; pull backward to tilt the forks back. The tilting speed is determined by the distance that the fingertip is moved.



Caution

- The multi-way valve is equipped with a front tilt self-locking valve. When the circuit is cut off, the mast cannot tilt forward even if the lever is pushed forward.

Sideshifter fingertip

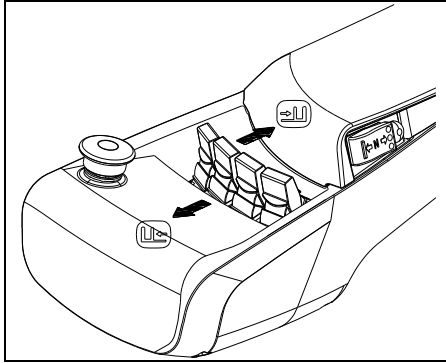

Pull and push the fingertip can realize the left/right movement of the mast.

Attachment fingertip

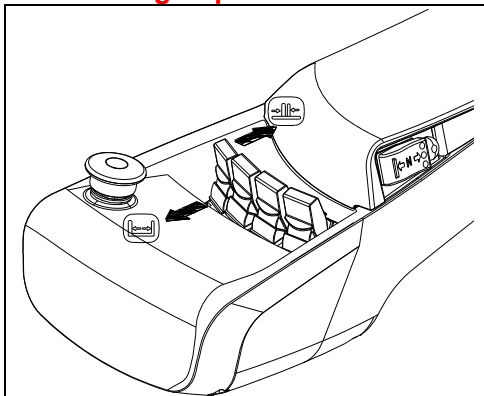

Apply when installing the attachment with 4th valve. Push and pull the fingertip can realise the attachment function.

Horn button

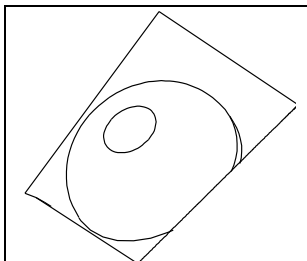

Press this button to send alert or warning signal.

Emergency stop button

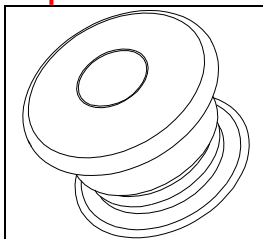

In an emergency, press the red mushroom head button to cut off the vehicle's main power supply.



Caution

- Do not use the emergency stop switch to stop the truck under normal circumstances as the key switch.

Level shift handle

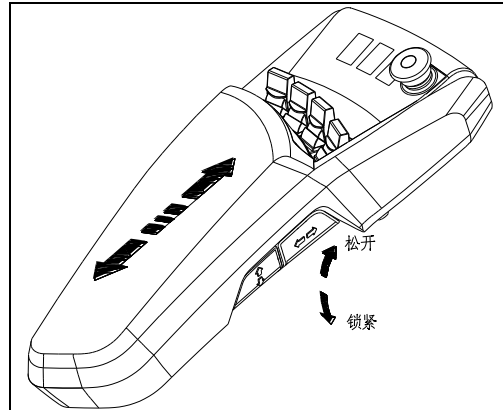

Adjust horizontal position of armrest: Flip the picks up, release the armrest and move it to proper position; Flip the picks down, lock the armrest.

Vertical shift handle

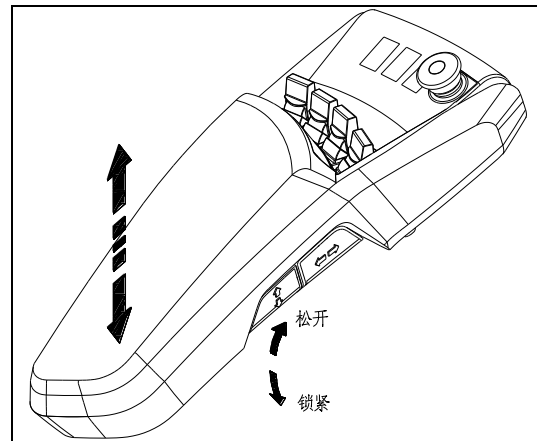

Adjust armrest height : Flip the picks up, release the armrest and vertically move it to proper position; Flip the picks down, lock the armrest.

Seat

Seat and seat adjustment lever

In order to guarantee safety operation of the forklift, adjust the seat (2) according to driver's need and fasten safety belt before operation. Incorrect seat adjustment may cause accident or endanger your health.

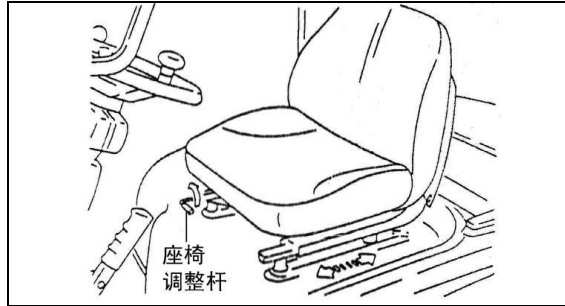

To adjust the seat position, pull up on the adjustment lever and press it to slide the seat forward or backward to adjust the seat to a comfortable, easy-to-operate position.

Then release the adjustment lever and the seat position is locked.

Before the operation, the operator has to adjust the seat and ensure that the seat is securely locked.

Warning

- The key switch must be turned off before adjusting the seat.
- The seat position can only be adjusted when the forklift truck stops.

Optional seat

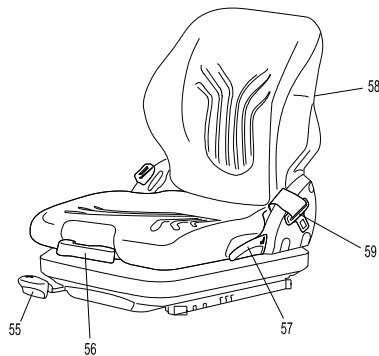

55. Positioning device lock lever

56. Weight adjusting lever

57. Backrest adjusting lever

58. Waist support adjusting knob

59. Safety belt

Seat adjustment

Adjust seat front/rear position

Procedures:

- Driver sits on.
- Pull the driver seat's positioning device lock lever (55) upward along the arrow direction.
- Move the seat forward or backward to suitable position.
- Lock driver seat's positioning device lock lever (55).

Seat position adjustment is finished.

Warning

- Driver seat's positioning device lock lever must be locked in the position.
- Never adjust driver seat during driving.

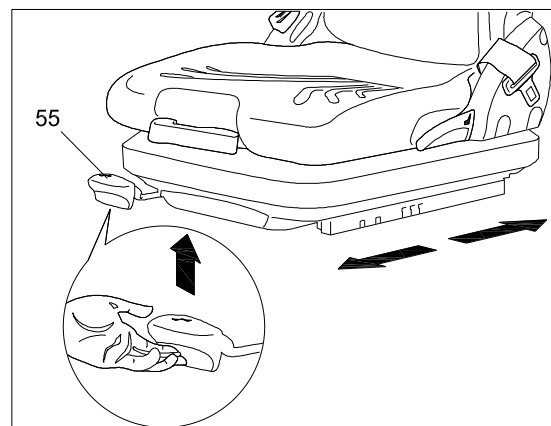

Adjust driver seat according to weight

In order to get ideal damping effect, adjust the seat according to driver's weight

Procedures:

- Pull out weight adjusting lever (56).
- Elevate and press weight adjusting lever (56) to increase seat bearing weight.
- Press and elevate weight adjusting lever (56) to reduce seat bearing weight.
- If arrow aims at the middle position of the window, it means the seat setting meets driver's weight. When reach the min. or max. weight, the lever will not work.
- After setting the weight, fully fold the weight adjusting lever (56).

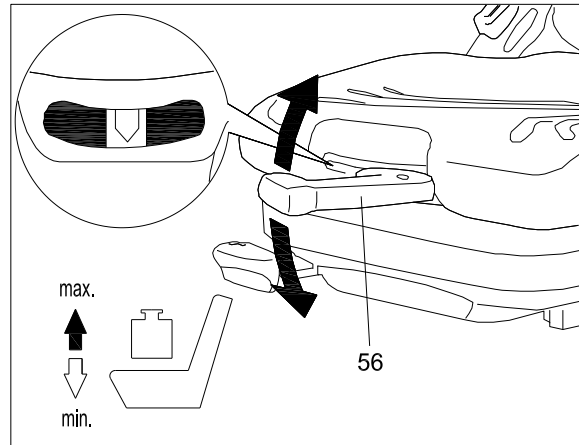

Warning

- Driver seat's positioning device lock lever must be locked in the position.
- Never adjust driver seat during driving.

Seat backrest adjustment

Procedures:

- Driver sits on.
- Pull the backrest adjusting lever (57) upward.
- Adjust backrest inclination.
- Release backrest adjusting lever (57) and lock backrest.

Backrest adjustment is finished.

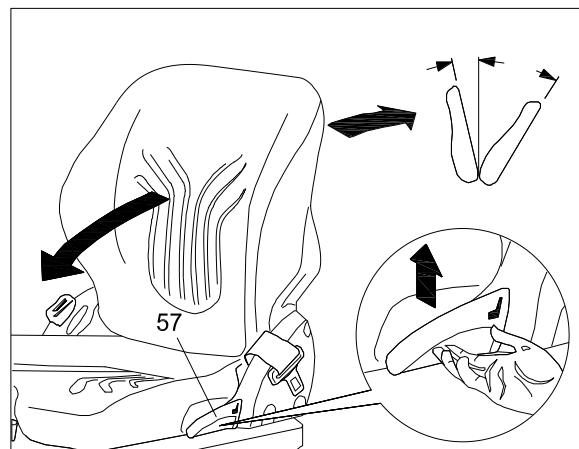

Seat waist support adjustment

Procedures:

Turn the waist support adjusting knob (58) to desired position.

Position 0 = no warping in lumbar vertebrae area.

Position 1 = increasing warping in upper lumbar vertebrae area.

Position 2 = increasing warping in lower lumbar vertebrae area.

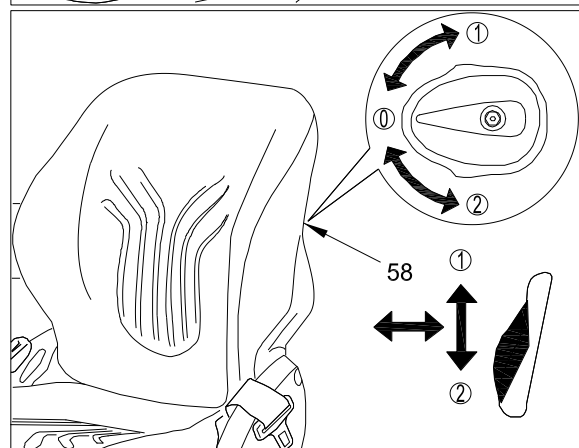

Safe belt

Put on the seat belt^④ each time before starting the truck. The belt protects against serious injury.

Protect the belt from contamination and clean it regularly.

Correct use the safe belt:

- Sit correctly on the seat.
- Check that seat belt is not twisted.
- Place the seat belt at hip level.
- Attach the seat belt and check that it locks.
- Adjust the seat belt to your body shape without squeezing your hip and without over-slack.

Regular verification of seat belt related to:

- Cut or frayed straps and Loose stitching.
- Worn or damaged hardware, including anchor points.
- Buckle or retractor malfunction.



WARNING

- In no event should the lift truck be used if the seat belt is defective (fixing, locking, cuts, tears, etc.). Repair or replace the seat belt immediately.
- Do not alter the belt setting. Always replace the seat belt after an accident.

Note:

Whenever the truck is switched-on and in drive mode, a visual warning will indicate to the operator if the safety belt is not buckled. When the safety belt is buckled, the visual warning will be switched-off.

If the safety belt is not buckled, an audible warning will be given after 20 s, after switch-on of the truck, or after detection of the operator by the operator control.

How to act in unusual situations

- Fasten seat belt, stay in seat.
- Do not jump !
- Lean forward, hold on tight steering wheel, brace feet.
- Lean your body away from impact.

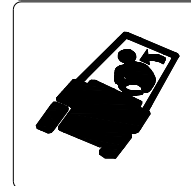
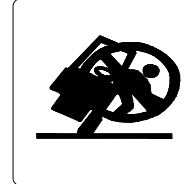
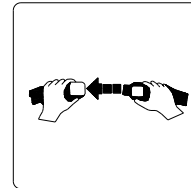

WARNING

- **If the truck is about to tip over, never undo the restraint belt and try to jump out. This will only increase the risk of serious injury or death !**

3.Nameplate and Safety Labels

Warnings and notices such as Rated capacities and load centers graph, Warning label and name plate must be legible at all times. Replace if necessary.

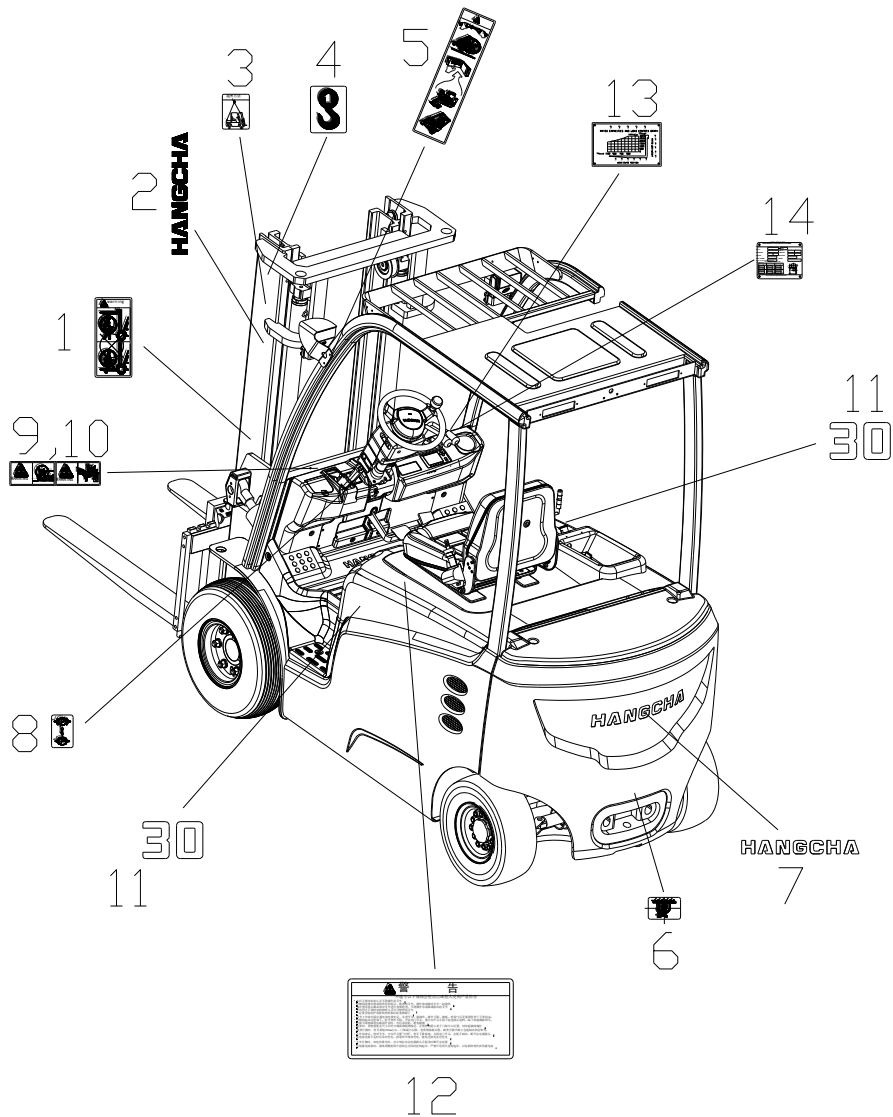

No.	Description
1	Warning label: Do not step onto or beneath the load
2	Hangcha fork
3	Hoisting method
4	Lift method
5	Seat belt label
6	Tethered point label
7	Hangcha fork
8	Hand brake label
9	Warning label: No climbing
10	Warning label: Risk of trapping with moving mast

No.	Description
11	Series and tonnage label
12	Warning label: Please abide by the operation instructions
13	Nameplate
14	Rated capacities and load centers graph

Nameplate:

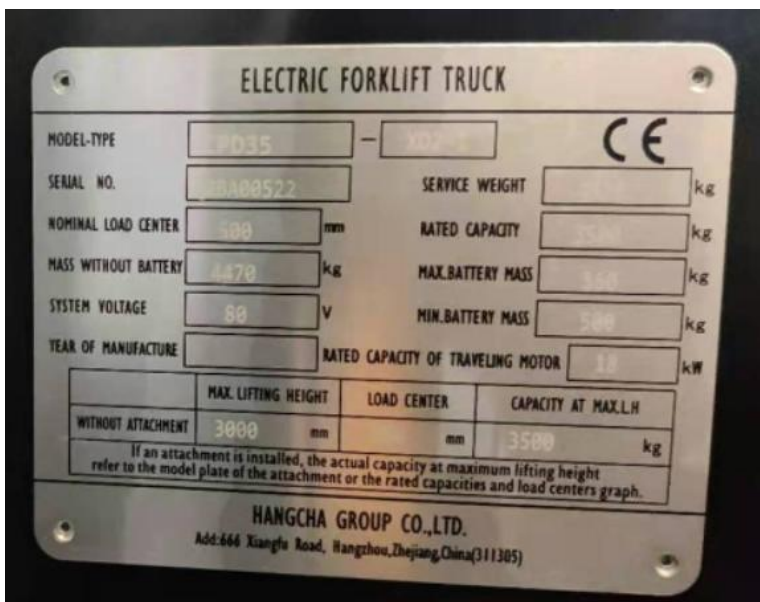
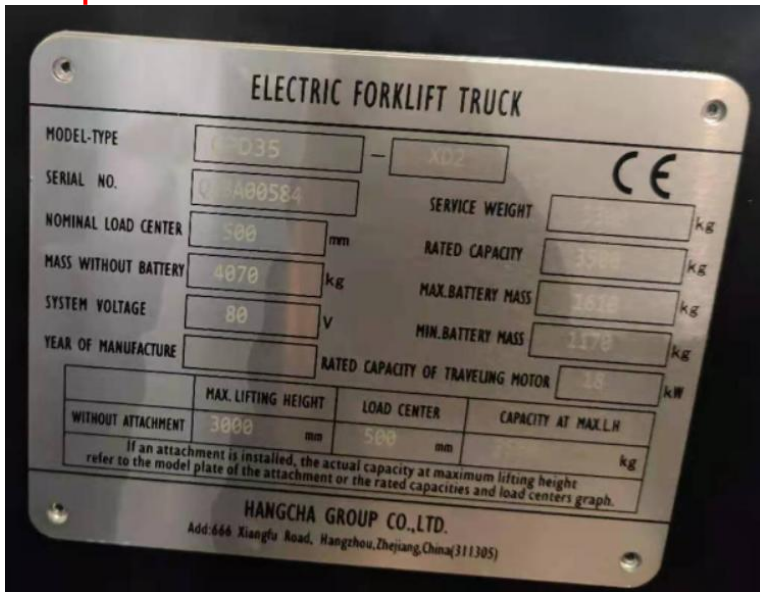

4. Technical Specifications

No.	Item		CPD20-XC4	CPD25-XC4	
1	Rated lifting capacity	kg	2000	2500	
2	Load center distance	mm	500	500	
3	lift height	max	3000	3000	
4		Free	140	140	
5	Mast Tilt angle (front/back)	(°)	6 / 10	6 / 10	
6	Maximum travel speed(full load/no load)	km/h	17	19	
7	Maximum lifting speed (full load/no load)	mm/s	360	340	
8	Maximum grade ability (full load/no load)	%	20	19	
9	Minimum outside turning radius	mm	1990	2055	
10	Minimum ground clearance	mm	120	120	
11	Maximum braking distance	m	2.5	2.5	
12	Dimensions	L	mm	2295	2347
		W	mm	1185	1180
		H	mm	2160	2160
13	Service weight	Include battery box	kg	3650	4150
14	Battery	Model		5PZS525	6PZB600
15		Voltage/Capacitance	V/Ah	48/525	48/600
16	Motor	Driven Motor	kW	18	18
		Pump Motor	kW	18	18
17	Tire	Front/Quantity		23x9-10/2	23x9-10/2
		Rear/Quantity		18x7-8/2	18x7-8/2

No.	Item		CPD30-XC4	CPD35-XC4	
1	Rated lifting capacity	kg	3000	3500	
2	Load center distance	mm	500	500	
3	lift height	max	3000	3000	
4		Free	135	135	
5	Mast Tilt angle (front/back)	(°)	6 / 10	6 / 10	
6	Maximum travel speed(full load/no load)	km/h	16.5	14	
7	Maximum lifting speed (full load/no load)	mm/s	320	300	
8	Maximum grade ability (full load/no load)	%	20	17	
9	Minimum outside turning radius	mm	2190	2230	
10	Minimum ground clearance	mm	120	120	
11	Maximum braking distance	m	2.5	2.5	
12	Dimensions	L	2487	2577	
		W	1180	1260	
		H	2160	2161	
13	Service weight	Include battery box	kg	4710	5300
14	Battery	Model	4PZS480	4PZS500	
15		Voltage/Capacitance	V/Ah	80/480	80/500
16	Motor	Driven Motor	kW	18	18
		Pump Motor	kW	18	18
17	Tire	Front/Quantity	23x9-10/2	23x10-12/2	
		Rear/Quantity	18x7-8/2	200/50-10/2	

No.	Item		CPD25-XC4-JC	CPD10-XC4	
1	Rated lifting capacity	kg	2500	1000	
2	Load center distance	mm	500	500	
3	lift height	max	3000	3000	
4		Free	140	155	
5	Mast Tilt angle (front/back)	(°)	6 / 10	6 / 10	
6	Maximum travel speed(full load/no load)	km/h	16.5	16.5	
7	Maximum lifting speed (full load/no load)	mm/s	340	450	
8	Maximum grade ability (full load/no load)	%	19	20	
9	Minimum outside turning radius	mm	2055	1845	
10	Minimum ground clearance	mm	120	85	
11	Maximum braking distance	m	2.5	2.5	
12	Dimensions	L	mm	2347	2080
		W	mm	1180	1060
		H	mm	2160	2070
13	Service weight	Include battery box	kg	4150	2570
14	Battery	Model		6PZB600	4PZS360
15		Voltage/Capacitance	V/Ah	48/600	48/360
16	Motor	Driven Motor	kW	15	11.3
		Pump Motor	kW	15	13.8
17	Tire	Front/Quantity		23x9-10/2	6.00-9/2
		Rear/Quantity		18x7-8/2	5.00-8/2

No.	Item		CPD35-XC4-I	CPD30-XC4-I	
1	Rated lifting capacity	kg	3500	3000	
2	Load center distance	mm	500	500	
3	lift height	max	3000	3000	
4		Free	135	135	
5	Mast Tilt angle (front/back)	(°)	6/10	6/10	
6	Maximum travel speed(full load/no load)	km/h	14	16.5	
7	Maximum lifting speed (full load/no load)	mm/s	300	320	
8	Maximum grade ability (full load/no load)	%	17	20	
9	Minimum outside turning radius	mm	2230	2195	
10	Minimum ground clearance	mm	120	120	
11	Maximum braking distance	m	2.5	2.5	
12	Dimensions	L	2562	2487	
		W	1260	1234	
		H	2160	2160	
13	Service weight	Include battery box	kg	4965	4320
14	Battery	Model		CATL	CATL
15		Voltage/Capacitance	V/Ah	80/404	80/404
16	Motor	Driven Motor	kW	18	18
		Pump Motor	kW	18	18
17	Tire	Front/Quantity		23x10-10/2	23x9-10/2
		Rear/Quantity		200/5-10/2	18x17-8/2

No.	Item		CPD25-XC4-I	CPD20-XC4-I
1	Rated lifting capacity	kg	2500	2000
2	Load center distance	mm	500	500
3	lift height	max	3000	3000
4		Free	140	140
5	Mast Tilt angle (front/back)	(°)	6/10	6/10
6	Maximum travel speed(full load/no load)	km/h	16.5	17
7	Maximum lifting speed (full load/no load)	mm/s	340	360
8	Maximum grade ability (full load/no load)	%	19	20
9	Minimum outside turning radius	mm	2055	1990
10	Minimum ground clearance	mm	120	120
11	Maximum braking distance	m	2.5	2.5
12	Dimensions	L	mm	2347
		W	mm	1185
		H	mm	2160
13	Service weight	Include battery box	kg	3950
14	Battery	Model		CATL
15		Voltage/Capacitance	V/Ah	51.52/500
16	Motor	Driven Motor	kW	18
		Pump Motor	kW	18
17	Tire	Front/Quantity		23x9-10/2
		Rear/Quantity		18x7-8/2

No.	Item		CPD18-XC4-I	CPD15-XC4-I	
1	Rated lifting capacity	kg	1750	1500	
2	Load center distance	mm	500	500	
3	lift height	max	mm	3000	3000
4		Free	mm	155	155
5	Mast Tilt angle (front/back)	(°)	6/10	6/10	
6	Maximum travel speed(full load/no load)	km/h	16	16	
7	Maximum lifting speed (full load/no load)	mm/s	370	420	
8	Maximum grade ability (full load/no load)	%	19	19	
9	Minimum outside turning radius	mm	1860	1845	
10	Minimum ground clearance	mm	85	85	
11	Maximum braking distance	m	2.5	2.5	
12	Dimensions	L	mm	2109	2080
		W	mm	1125	1060
		H	mm	2070	2070
13	Service weight	Include battery box	kg	2965	2805
14	Battery	Model		CATL	CATL
15		Voltage/Capacitance	V/Ah	48/404	48/404
16	Motor	Driven Motor	kW	11.3	11.3
		Pump Motor	kW	13.8	13.8
17	Tire	Front/Quantity		21×8-9/2	6.00-9/2
		Rear/Quantity		5.00-8/2	5.00-8/2

No.	Item		CPD10-XC4-I	CPD20-XC4-JC
1	Rated lifting capacity	kg	1000	2000
2	Load center distance	mm	500	500
3	lift height	max	3000	3000
4		Free	155	140
5	Mast Tilt angle (front/back)	(°)	6/10	6/10
6	Maximum travel speed(full load/no load)	km/h	16.5	17
7	Maximum lifting speed (full load/no load)	mm/s	450	360
8	Maximum grade ability (full load/no load)	%	20	20
9	Minimum outside turning radius	mm	1845	1990
10	Minimum ground clearance	mm	85	120
11	Maximum braking distance	m	2.5	2.5
12	Dimensions	L	2080	2295
		W	1060	1185
		H	2070	2160
13	Service weight	Include battery box	2375	3650
14	Battery	Model	CATL	5PZS525
15		Voltage/Capacitance	48/271	48/525
16	Motor	Driven Motor	11.3	18
		Pump Motor	13.8	18
17	Tire	Front/Quantity	6.00-9/2	23×9-10/2
		Rear/Quantity	5.00-8/2	18×7-8/2

No.	Item		CPD25-XC4-JCI	CPD20-XC4-JCI	
1	Rated lifting capacity	kg	2500	2000	
2	Load center distance	mm	500	500	
3	lift height	max	3000	3000	
4		Free	140	140	
5	Mast Tilt angle (front/back)	(°)	6/10	6/10	
6	Maximum travel speed(full load/no load)	km/h	16	16.5	
7	Maximum lifting speed (full load/no load)	mm/s	340	360	
8	Maximum grade ability (full load/no load)	%	19	20	
9	Minimum outside turning radius	mm	2055	1990	
10	Minimum ground clearance	mm	120	120	
11	Maximum braking distance	m	2.5	2.5	
12	Dimensions	L	mm	2320	2295
		W	mm	1180	1185
		H	mm	2160	2160
13	Service weight	Include battery box	kg	3920	3573
14	Battery	Model		CATL	CATL
15		Voltage/Capacitance	V/Ah	48.3/542	48.3/542
16	Motor	Driven Motor	kW	18	18
		Pump Motor	kW	18	18
17	Tire	Front/Quantity		23x9-10/2	23×9-10/2
		Rear/Quantity		18x7-8/2	18×7-8/2

No.	Item		CPD20-XXC4	CPD25-XLC4
1	Rated lifting capacity	kg	2000	2500
2	Load center distance	mm	500	500
3	lift height	max	3000	3000
4		Free	160	140
5	Mast Tilt angle (front/back)	(°)	6 / 10	6 / 10
6	Maximum travel speed(full load/no load)	km/h	16	16.5
7	Maximum lifting speed (full load/no load)	mm/s	360	400
8	Maximum grade ability (full load/no load)	%	17	20
9	Minimum outside turning radius	mm	1888	2148
10	Minimum ground clearance	mm	85	120
11	Maximum braking distance	m	2.5	2.5
12	Dimensions	L	2149	2435
		W	1125	1235
		H	2070	2160
13	Service weight	Include battery box	3380	4130
14	Battery	Model	4PZS480	4PZS480
15		Voltage/Capacitance	48/480	80/480
16	Motor	Driven Motor	11.3	18
		Pump Motor	13.8	18
17	Tire	Front/Quantity	21×8-9/2	23×9-10/2
		Rear/Quantity	5.00-8/2	18×7-8/2

No.	Item		CPD20-XXC4-I	CPD25-XLC4-I
1	Rated lifting capacity	kg	2000	2500
2	Load center distance	mm	500	500
3	lift height	max	3000	3000
4		Free	160	140
5	Mast Tilt angle (front/back)	(°)	6 / 10	6 / 10
6	Maximum travel speed(full load/no load)	km/h	16	16.5
7	Maximum lifting speed (full load/no load)	mm/s	360	400
8	Maximum grade ability (full load/no load)	%	17	20
9	Minimum outside turning radius	mm	1888	2195
10	Minimum ground clearance	mm	85	120
11	Maximum braking distance	m	2.5	2.5
12	Dimensions	L	2149	2460
		W	1125	1235
		H	2070	2160
13	Service weight	Include battery box	3150	3850
14	Battery	Model	CATL	CATL
15		Voltage/Capacitance	48.3/404	80.5/404
16	Motor	Driven Motor	11.3	18
		Pump Motor	13.8	18
17	Tire	Front/Quantity	21×8-9/2	23×9-10/2
		Rear/Quantity	5.00-8/2	18×7-8/2

No.	Item		CPD50-XC4	CPD45-XC4	
1	Rated lifting capacity	kg	5000	4500	
2	Load center distance	mm	500	500	
3	lift height	max	mm	3000	3000
4		Free	mm	150	150
5	Mast Tilt angle (front/back)	(°)	5/10	5/10	
6	Maximum travel speed(full load/no load)	km/h	13.5	16	
7	Maximum lifting speed (full load/no load)	mm/s	300	330	
8	Maximum grade ability (full load/no load)	%	14	16	
9	Minimum outside turning radius	mm	2680	2600	
10	Minimum ground clearance	mm	152	152	
11	Maximum braking distance	m	2.5	2.5	
12	Dimensions	L	mm	3075	2990
		W	mm	1486	1385
		H	mm	2360	2360
13	Service weight	Include battery box	kg	7750	6970
14	Battery	Model		5PZS700	5PZS700
15		Voltage/Capacitance	V/Ah	80/700	80/700
16	Motor	Driven Motor	kW	20	18
		Pump Motor	kW	25.4	25.4
17	Tire	Front/Quantity		28×12.5-15/2	250-15/2
		Rear/Quantity		23×9-12/2	23×9-10/2

No.	Item		CPD40-XC4	CPD40-XC4-I	
1	Rated lifting capacity	kg	4000	4000	
2	Load center distance	mm	500	500	
3	lift height	max	mm	3000	3000
4		Free	mm	150	150
5	Mast Tilt angle (front/back)	(°)	5/10	5/10	
6	Maximum travel speed(full load/no load)	km/h	16.5	16.5	
7	Maximum lifting speed (full load/no load)	mm/s	330	330	
8	Maximum grade ability (full load/no load)	%	17	17	
9	Minimum outside turning radius	mm	2540	2600	
10	Minimum ground clearance	mm	152	152	
11	Maximum braking distance	m	2.5	2.5	
12	Dimensions	L	mm	2910	2990
		W	mm	1385	1380
		H	mm	2360	2360
13	Service weight	Include battery box	kg	6560	5790
14	Battery	Model		4PZS600	CATL
15		Voltage/Capacitance	V/Ah	80/600	80.5/542
16	Motor	Driven Motor	kW	18	18
		Pump Motor	kW	25.4	25.4
17	Tire	Front/Quantity		250-15/2	250-15/2
		Rear/Quantity		23×9-10/2	23×9-10/2

No.	Item		CPD50-XC4-I	CPD45-XC4-I	
1	Rated lifting capacity	kg	4990	4500	
2	Load center distance	mm	600	500	
3	lift height	max	3000	3000	
4		Free	150	150	
5	Mast Tilt angle (front/back)	(°)	5/10	5/10	
6	Maximum travel speed(full load/no load)	km/h	15.5	16	
7	Maximum lifting speed (full load/no load)	mm/s	310	330	
8	Maximum grade ability (full load/no load)	%	15	16	
9	Minimum outside turning radius	mm	2680	2600	
10	Minimum ground clearance	mm	152	152	
11	Maximum braking distance	m	2.5	2.5	
12	Dimensions	L	3075	2990	
		W	1494	1385	
		H	2360	2360	
13	Service weight	Include battery box	kg	6750	6030
14	Battery	Model		CATL	CATL
15		Voltage/Capacitance	V/Ah	80.5/542	80.5/542
16	Motor	Driven Motor	kW	20	18
		Pump Motor	kW	25.4	25.4
17	Tire	Front/Quantity		28×12.5-15/2	250-15/2
		Rear/Quantity		23×9-10/2	23×9-10/2

No.	Item		CPD50-XXC4	CPD50-XXC4-I	
1	Rated lifting capacity	kg	4990	4990	
2	Load center distance	mm	500	500	
3	lift height	max	mm	3000	3000
4		Free	mm	150	150
5	Mast Tilt angle (front/back)	(°)	5/10	5/10	
6	Maximum travel speed(full load/no load)	km/h	16	16	
7	Maximum lifting speed (full load/no load)	mm/s	310	310	
8	Maximum grade ability (full load/no load)	%	16	16	
9	Minimum outside turning radius	mm	2600	2620	
10	Minimum ground clearance	mm	152	152	
11	Maximum braking distance	m	2.5	2.5	
12	Dimensions	L	mm	2990	3065
		W	mm	1494	1494
		H	mm	2360	2360
13	Service weight	Include battery box	kg	7210	6290
14	Battery	Model		5PZS700	CATL
15		Voltage/Capacitance	V/Ah	80/700	80.5/542
16	Motor	Driven Motor	kW	20	18
		Pump Motor	kW	25.4	25.4
17	Tire	Front/Quantity		28×12.5-15/2	28×12.5-15/2
		Rear/Quantity		23×9-10/2	23×9-10/2

No.	Item		CPD10-XD2	CPD15-XD2	
1	Rated lifting capacity	kg	1000	1500	
2	Load center distance	mm	500	500	
3	lift height	max	3000	3000	
4		Free	155	155	
5	Mast Tilt angle (front/back)	(°)	6/10	6/10	
6	Maximum travel speed(full load/no load)	km/h	16.5	16	
7	Maximum lifting speed (full load/no load)	mm/s	450	420	
8	Maximum grade ability (full load/no load)	%	20	20	
9	Minimum outside turning radius	mm	1845	1845	
10	Minimum ground clearance	mm	85	85	
11	Maximum braking distance	m	4	4	
12	Dimensions	L	2080	2080	
		W	1060	1060	
		H	2070	2070	
13	Service weight	Include battery box	kg	2760	2950
14	Battery	Model		3PZS360	4PZS420
15		Voltage/Capacitance	V/Ah	48/360	48/420
16	Motor	Driven Motor	kW	11.3	11.3
		Pump Motor	kW	13.8	13.8
17	Tire	Front/Quantity		6.00-9/2	6.00-9/2
		Rear/Quantity		5.00-8/2	5.00-8/2

No.	Item		CPD18-XD2	CPD20-XXD2	
1	Rated lifting capacity	kg	1750	2000	
2	Load center distance	mm	500	500	
3	lift height	max	3000	3000	
4		Free	155	160	
5	Mast Tilt angle (front/back)	(°)	6/10	6/10	
6	Maximum travel speed(full load/no load)	km/h	16	16	
7	Maximum lifting speed (full load/no load)	mm/s	370	370	
8	Maximum grade ability (full load/no load)	%	17	17	
9	Minimum outside turning radius	mm	1845	1888	
10	Minimum ground clearance	mm	85	85	
11	Maximum braking distance	m	4	6.4	
12	Dimensions	L	2085	2149	
		W	1125	1125	
		H	2070	2070	
13	Service weight	Include battery box	kg	3110	3380
14	Battery	Model	4PZS420	6DB450H	
15		Voltage/Capacitance	V/Ah	48/420	48/480
16	Motor	Driven Motor	kW	11.3	11.3
		Pump Motor	kW	13.8	13.8
17	Tire	Front/Quantity	21×8-9/2	21×8-9/2	
		Rear/Quantity	5.00-8/2	5.00-8/2	

No.	Item		CPD20-XD2	CPD25-XD2	
1	Rated lifting capacity	kg	2000	2500	
2	Load center distance	mm	500	500	
3	lift height	max	3000	3000	
4		Free	140	140	
5	Mast Tilt angle (front/back)	(°)	6/10	6/10	
6	Maximum travel speed(full load/no load)	km/h	17	16.5	
7	Maximum lifting speed (full load/no load)	mm/s	360	340	
8	Maximum grade ability (full load/no load)	%	20	19	
9	Minimum outside turning radius	mm	1990	2055	
10	Minimum ground clearance	mm	120	120	
11	Maximum braking distance	m	6.7	6.7	
12	Dimensions	L	2295	2347	
		W	1185	1185	
		H	2160	2160	
13	Service weight	Include battery box	kg	3650	4150
14	Battery	Model	5PZS525	5PZS600	
15		Voltage/Capacitance	V/Ah	48/525	48/600
16	Motor	Driven Motor	kW	18	18
		Pump Motor	kW	18	18
17	Tire	Front/Quantity	23×9-10/2	23×9-10/2	
		Rear/Quantity	18×7-8/2	18×7-8/2	

No.	Item		CPD25-XLD2	CPD30-XD2	
1	Rated lifting capacity	kg	2500	3000	
2	Load center distance	mm	500	500	
3	lift height	max	3000	3000	
4		Free	140	135	
5	Mast Tilt angle (front/back)	(°)	6/10	6/10	
6	Maximum travel speed(full load/no load)	km/h	16.5	16.5	
7	Maximum lifting speed (full load/no load)	mm/s	400	320	
8	Maximum grade ability (full load/no load)	%	20	20	
9	Minimum outside turning radius	mm	2148	2195	
10	Minimum ground clearance	mm	120	120	
11	Maximum braking distance	m	6.7	6.7	
12	Dimensions	L	2435	2487	
		W	1235	1180	
		H	2160	2160	
13	Service weight	Include battery box	kg	4230	4710
14	Battery	Model	4PZS480	4PZS480	
15		Voltage/Capacitance	V/Ah	80/480	80/480
16	Motor	Driven Motor	kW	18	18
		Pump Motor	kW	18	18
17	Tire	Front/Quantity	23×9-10/2	23×9-10/2	
		Rear/Quantity	18×7-8/2	18×7-8/2	

No.	Item		CPD35-XD2	CPD10-XD2-I
1	Rated lifting capacity	kg	3500	1000
2	Load center distance	mm	500	500
3	lift height	max	mm	3000
4		Free	mm	135
5	Mast Tilt angle (front/back)	(°)	6/10	6/10
6	Maximum travel speed(full load/no load)	km/h	14	16.5
7	Maximum lifting speed (full load/no load)	mm/s	300	450
8	Maximum grade ability (full load/no load)	%	17	20
9	Minimum outside turning radius	mm	2230	1845
10	Minimum ground clearance	mm	120	85
11	Maximum braking distance	m	5.2	4
12	Dimensions	L	mm	2577
		W	mm	1260
		H	mm	2161
13	Service weight	Include battery box	kg	5300
14	Battery	Model	4PZS480	CATL 6LH3L8
15		Voltage/Capacitance	V/Ah	80/480
16	Motor	Driven Motor	kW	18
		Pump Motor	kW	18
17	Tire	Front/Quantity	23×10-12/2	6.00-9/2
		Rear/Quantity	200/50-10/2	5.00-8/2

No.	Item		CPD15-XD2-I	CPD18-XD2-I	
1	Rated lifting capacity	kg	1500	1750	
2	Load center distance	mm	500	500	
3	lift height	max	3000	3000	
4		Free	155	155	
5	Mast Tilt angle (front/back)	(°)	6/10	6/10	
6	Maximum travel speed(full load/no load)	km/h	16.5	16	
7	Maximum lifting speed (full load/no load)	mm/s	420	370	
8	Maximum grade ability (full load/no load)	%	19	19	
9	Minimum outside turning radius	mm	1845	1860	
10	Minimum ground clearance	mm	85	85	
11	Maximum braking distance	m	4	4	
12	Dimensions	L	2080	2144	
		W	1060	1125	
		H	2070	2070	
13	Service weight	Include battery box	kg	2750	2970
14	Battery	Model	CATL 6LH3L8	CATL 6LH3L8	
15		Voltage/Capacitance	V/Ah	48/404	48/404
16	Motor	Driven Motor	kW	11.3	11.3
		Pump Motor	kW	13.8	13.8
17	Tire	Front/Quantity	6.00-9/2	21×8-9/2	
		Rear/Quantity	5.00-8/2	5.00-8/2	

No.	Item		CPD20-XXD2-I	CPD20-XD2-I	
1	Rated lifting capacity	kg	2000	2000	
2	Load center distance	mm	500	500	
3	lift height	max	3000	3000	
4		Free	160	140	
5	Mast Tilt angle (front/back)	(°)	6/10	6/10	
6	Maximum travel speed(full load/no load)	km/h	16	16.5	
7	Maximum lifting speed (full load/no load)	mm/s	370	360	
8	Maximum grade ability (full load/no load)	%	17	20	
9	Minimum outside turning radius	mm	1888	1990	
10	Minimum ground clearance	mm	85	120	
11	Maximum braking distance	m	6.4	6.7	
12	Dimensions	L	2149	2295	
		W	1125	1185	
		H	2070	2160	
13	Service weight	Include battery box	kg	3180	3430
14	Battery	Model	CATL 6LH3L8	CATL 6LH3L8	
15		Voltage/Capacitance	V/Ah	48/404	48/500
16	Motor	Driven Motor	kW	11.3	18
		Pump Motor	kW	13.8	18
17	Tire	Front/Quantity	21×8-9/2	23×9-10/2	
		Rear/Quantity	5.00-8/2	18×7-8/2	

No.	Item		CPD25-XD2-I	CPD25-XLD2-I	
1	Rated lifting capacity	kg	2500	2500	
2	Load center distance	mm	500	500	
3	lift height	max	3000	3000	
4		Free	140	140	
5	Mast Tilt angle (front/back)	(°)	6/10	6/10	
6	Maximum travel speed(full load/no load)	km/h	16	16.5	
7	Maximum lifting speed (full load/no load)	mm/s	340	400	
8	Maximum grade ability (full load/no load)	%	19	20	
9	Minimum outside turning radius	mm	2055	2195	
10	Minimum ground clearance	mm	120	120	
11	Maximum braking distance	m	6.7	6.7	
12	Dimensions	L	2320	2460	
		W	1185	1235	
		H	2160	2160	
13	Service weight	Include battery box	kg	3720	3850
14	Battery	Model	CATL 6LH3L8	CATL 6LH3L8	
15		Voltage/Capacitance	V/Ah	482/500	80/404
16	Motor	Driven Motor	kW	18	18
		Pump Motor	kW	18	18
17	Tire	Front/Quantity	23×9-10/2	23×9-10/2	
		Rear/Quantity	18×7-8/2	18×7-8/2	

No.	Item		CPD30-XD2-I	CPD35-XD2-I	
1	Rated lifting capacity	kg	3000	3500	
2	Load center distance	mm	500	500	
3	lift height	max	3000	3000	
4		Free	135	135	
5	Mast Tilt angle (front/back)	(°)	6/10	6/10	
6	Maximum travel speed(full load/no load)	km/h	16	14	
7	Maximum lifting speed (full load/no load)	mm/s	320	300	
8	Maximum grade ability (full load/no load)	%	20	17	
9	Minimum outside turning radius	mm	2195	2230	
10	Minimum ground clearance	mm	120	120	
11	Maximum braking distance	m	6.7	5.2	
12	Dimensions	L	mm	2561	2562
		W	mm	1185	1260
		H	mm	2160	2160
13	Service weight	Include battery box	kg	4370	4965
14	Battery	Model		CATL 6LH3L8	CATL 6LH3L8
15		Voltage/Capacitance	V/Ah	80/404	80/404
16	Motor	Driven Motor	kW	18	18
		Pump Motor	kW	18	18
17	Tire	Front/Quantity		23×9-10/2	23×10-12/2
		Rear/Quantity		18×7-8/2	200/50-10/2

5. Safety Instructions

1. Only trained and authorized operator shall be permitted to operate the truck.

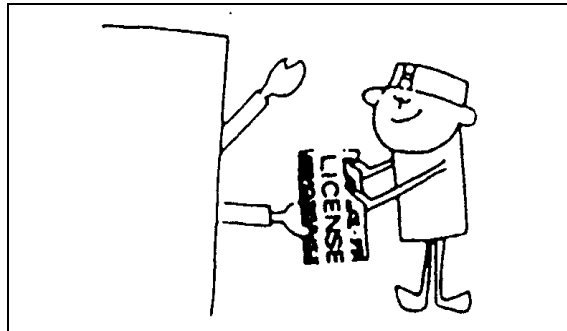

2. Inspect the truck at periodic intervals for oil or water leak, deformation, lousiness, etc. If neglected, short life of components will be caused and in the worst case a fatal accident would occur.

- Make sure having replaced good parts during periodic check.
- Wipe off oil, grease or water from the floor board and foot and hand controls, if any.
- Strictly prohibit smoking and spark nearby the storage battery when checking it.
- If maintenance on high position, such as mast, front and rear lamp, please be careful to prevent fall down or be clamped.
- Be careful do not be scalded when inspect the motor, controller and etc.

3. whatsoever in trouble, you must stop the forklift, hang a mark of "danger" or "trouble" and take off the key, at the same time inform the manager. Only after the trouble is removed, you may use the forklift.

- If trouble occurs when lifting cargo, to Climb or descend, or the storage battery electrolyte, the hydraulic fluid, the brake fluid has the revelation, please organizes the personnel to repair immediately.

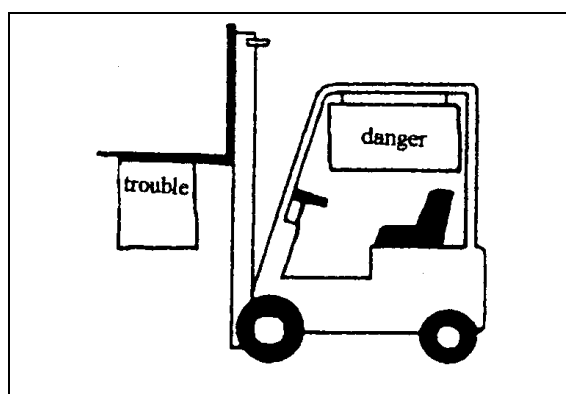

4. Operator must wear helmet, safety shoes and work clothes.
5. Because there will bring exploding gas in the bosom of the battery, prohibit any flame nearby it absolutely.
 - Do not let any tools close the two terminal of the battery to avoid spark or short circuit.
6. The movement road of forklift should be solid and smooth coagulation road or similar to the road suitable for vehicle. Recheck the state of working ground.

- The considered climatic conditions when the forklift designs are: Temperature - 20°C-50°C; the wind speed does not surpass 5m/s; the air relative humidity is not bigger than 90% (temperature 20°C).
 - The forklift is not suitable in the flammable explosive working conditions.
 - Altitude: No more than 2000 meters.
7. Never mount or dismount the moving truck. Use the safety step(s) and safety grip facing the truck when mounting or dismounting the truck.

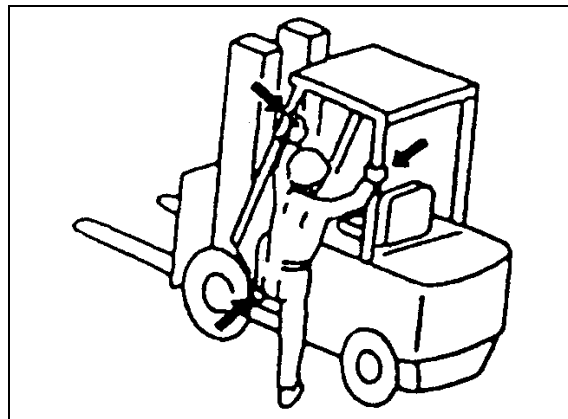

8. Never attempt to work the controls unless properly seated.
- Before starting, adjust the seat so you can get easy access to all hand and foot control.
9. Before starting up, make sure that:
- Please fasten seat bolts.
 - The parking brake lever is applied securely.
 - The forward-reverse lever is in neutral.
 - Before starting, make sure no one is under, on and close to the truck.
 - Don't step the accelerate pedal or control the lifting lever or tilting lever before turning on power.
10. Operate the controls smoothly. Avoid sudden stops or turns.
- It is dangerous to make a sharp brake. Otherwise the truck has the possibility of overturn.
11. Pay attention to the route of the truck; be sure to make a wide sight.

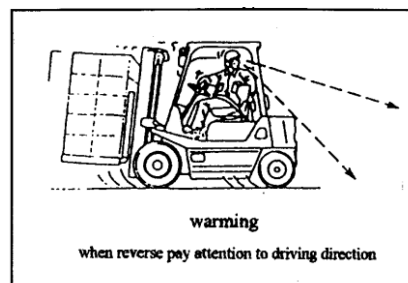

12. Never allow other person(s) to ride on the forks, pallets or on the truck.
13. Taking account of the shape and material of loads to be handled, use a proper attachment and tools.
- Avoid hoisting the load, with wire rope hung on the forks or attachment, since the wire rope may slide off. If needed, a qualified personnel for slinging operation should perform, making

use of a hook or crane arm attachment.

- Take care not to protrude the forks out of the load. The protruded fork tips may damage or turn over the adjacent load.
- 14.** Know the rated capacity of your lift truck and its attachment, if any, and never exceed it.
- Do not use a man as an additional counterweight. It's quite dangerous.



15. Keep your mind on your work.

16. Keep your head, hands, arms, feet and legs within the confines of the operator's compartment. Never stretch out for any reason.



17. The pallet and skid used should be strong enough to endure the load. Never use damaged or deformed ones.

18. We afford all type of attachment, such as rotating roll clamp, bale clamp, side shifter, and crane jib etc. You should refit the truck under ours license if you want. It is forbidden to refit it by yourself.

19. Safeguard protect you do not be hurt by the goods fallen. Load bracket protect you load goods smoothly. It is forbidden to use truck without safeguard or load bracket.

20. It is forbidden to walk down the fork or the attachment.

- It is forbidden to walk up the fork or stand on the fork.

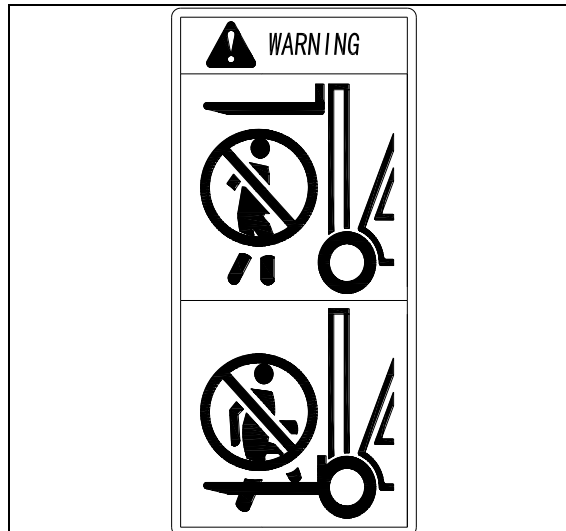

21. It is forbidden to put your hands, arms or head stretch between the mast and safeguard. Once clamped, the life has danger.

- It is forbidden to put your hands in inner and outer mast.

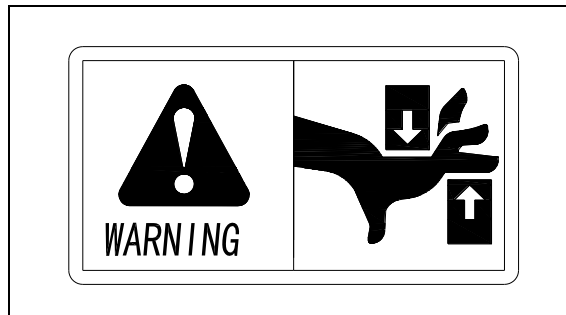

22. The goods is liable to drop turning or passing rough road when it depatures the center. And the forklift may turn over more probably.

23. Don't stack loads on forks in such a way that the top of loads exceeds the load backrest height. If unavoidable, make sure the load is fastened. When handling bulky loads that restrict your vision operate the truck in reverse or have a guide. When lead by a guide, make sure you understand hand, flag, whistle or other signals. When handling long loads such as pipe, lumber etc or in the case of the Large-sized model, or operate with long attachment, be extremely careful of load end swing at corners or in narrow aisles. Be alert for others.

24. Use minimum forward and reverse tilt when stacking and un-stacking loads. Never tilt forward unless load is over stack or at low lift height.

- When stacking loads on a high place, once make the mast vertical at a height of 15 to 20 cm above the ground and then lift the load farther. Never attempt to tilt the mast beyond vertical when the load is raised high.
- To un-stack loads from a high place, insert forks into the pallet and drive backwards, then lower the load. Tilt the mast backwards after lowering. Never attempt to tilt the mast with the load raised high.

25. It is dangerous to travel with forks higher than appropriate position regardless of whether loaded or not. Keep the good traveling posture. (When traveling, the forks should be 15 to 30 cm

above the ground or floor and the mast tilted backward)

- Do not operate the side shift mechanism, if equipped, when the forks are raised and loaded, since this will cause the truck to be unbalanced.

26. Watch for branches, cables, doorways, or overhangs. Pay caution when working in congested areas.

- Slow down and sound horn at cross aisles and other locations where vision is restricted.
- When make a turn, be sure the speed of the truck is lower than the 1/3 max. of allowable speed.

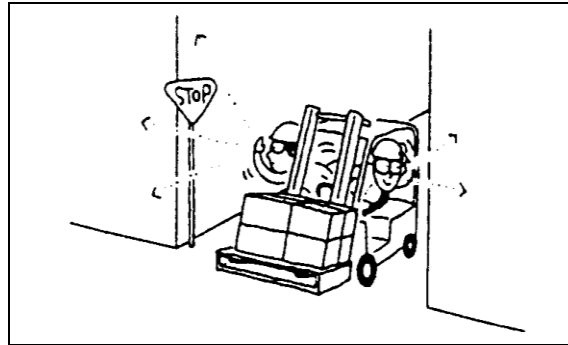

27. Affirm keeping some distance from roadside and flat roof.

28. Before driving over a dock-board or bridge-plate, be sure that it is properly secured and strong enough to sustain the weigh.

29. When operating loaded truck, have the rear end of your machine pointed downhill.

- When operating unloaded truck, have the rear end of your machine pointed upgrade.
- Do not make a turn on the grade, in order to avoid overturn.

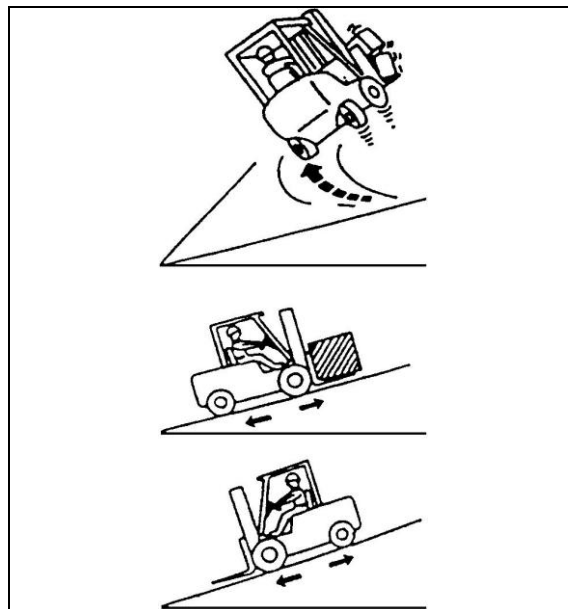

30. the goods is liable to drop turning or passing rough road when it departs the center. And the forklift may turn over more probably.

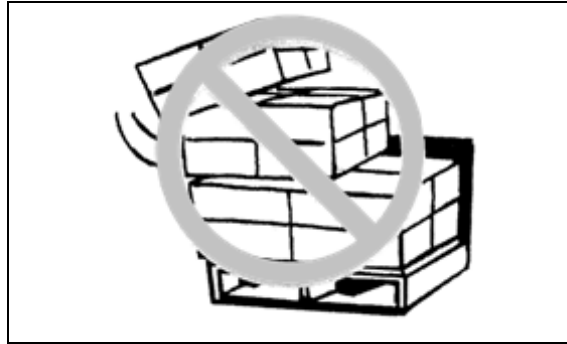

- 31.** Never lift loads with the truck inclined. Avoid loading work on a grade.
- 32.** Never permit anyone to stand or walk under upraised forks or other attachments if machine is so equipped. If unavoidable, use a safety stand or block to prevent a possibility of fork attachments falling down or moving unexpectedly.
- 33.** Inspect the surface over which you will run. Look for holes, drop-offs, obstacles, and look for rough spots. Look for anything that might cause you to lose control, bog down or upset.
 - Clear away trash and debris. Pick up anything that might puncture a tire or let the load lose balance.
 - Slow down for wet and slippery roads. Stay away from the edge of the road. If unavoidable, pay more attention.
 - Do not operate the truck when the weather is execrable, such as windy, thunder storm, snow and etc. Especially when wind speed is higher than 5m/s, don't operate the truck outside.
- 34.** An accumulator is required for controller. Forbid to touch within B+ and B- to prevent from wounding by electricity. Before checking or cleaning, please connect loads (contactor circuit or horn for example) between B+ and B- first to discharge for capacitor of controller.
- 35.** Pulling the hand brake when parking on flat. If necessarily parking on ramp, you should place the wedges under wheels.
 - Descending the fork to the ground and keeping a little forward tilting, shut off key switch and take off key.
 - Pull out the battery plug.
 - The parking place must be far away from fireworks.
- 36.** You can tow the forklift to the safe place with towing pin when the forklift can't run.
 - Don't tow the truck which steering system or brake system has been damaged.
- 37.** There is operating method and warning label on the truck. Please operate the truck obey the rules on the label and this manual. Often inspect the nameplate, when damaged or lost please replace it.
- 38.** Fire extinguisher must be prepared at working place. Users can select fire extinguisher along with truck, and it usually is fixed on rear supported leg of safety shelf, it is easy to pick.
 - Driver and manager should be familiar with the position and operation of fire extinguisher.
- 39.** Please use stock when conveying little goods, it is forbidden to use fork directly.
- 40.** Cold storage truck are not allowed to park in the cold storage

41. There are some chemical corrosive substances on the anti-corrosion truck surface, such as acid, alkali and salt etc. liquid, remove timely to avoid forklift corrosion.

42. In a corrosive environment, especially in heavy corrosion environment, such as acid, alkali, salt and other chemical etching medium, severe operation conditions as high temperature, humidity and dust etc., anti-corrosion truck cannot work continuously or park for a long time.

6.Forklift Transport,Lifting & Towing

Transport

- The Fork Lift Truck is designed for material handling only, It is inappropriate for long-distance transportation. If needed, the Fork Lift Truck must be transported by ship, train or lorry, of 5T loading. Use a lifting pallet to hoist the truck.
- Use the steel wire ropes to tie the holes in the two side of the outside mast's beam and the rear of truck's body, and then use the lifting device to hoist the truck.

Lifting

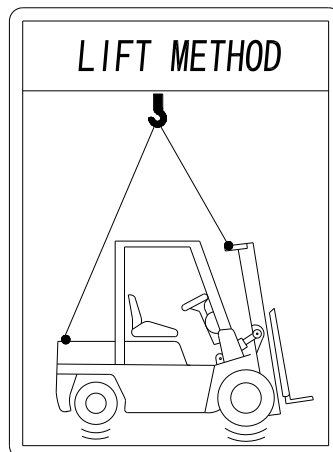

Use the steel wire ropes to tie the holes in the two side of the outside mast's beam and the hook of the counter balance, and then use the lifting device to hoist the truck. The steel wire rope attach to the counterweight should through the safeguard gap, and make the safeguard not be distorted.



WARNING

- **When hoist the truck, don't coil the overhead guard with the steel wire.**
- **The steel wire ropes and the lifting device must be very firm to support the truck because the truck is very heavy.**
- **Don't lift the truck by hoist the overhead guard.**
- **When lifting the truck, don't take yourself below the truck.**

Towing

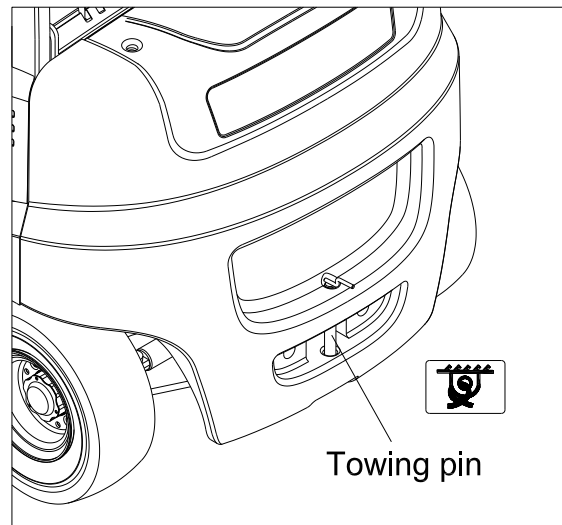

- The towing rod on the bottom of the counter balance is used to pull and drag the truck.
- Turn off key and pull out power switch.
- Loosen the brake lever.
- Set switch lever to neutral position.



WARNING

- **Don't tie the steel wire ropes on the unfixed position.**
- **Don't carry a load to steel wire ropes suddenly.**
- **The truck would be damaged if you tow it with the electric lock working.**
- **The electromagnetic brake forklift truck would be damaged if you tow it, prohibited drag electromagnetic brake forklift truck!**

7.The Structure and Stability of Truck

Prevent the forklift to turn over! It is very important for operator to know the truck's structure and relationship between load and stability.

CAUTION **Structure**

The basic structure of the truck is mast (include mast and forks) and body (include tire).
 The lift truck keeps the balance of weight between the truck body and the load on the forks with the center of the front wheels as a fulcrum when the rated capacity load is placed in position.
 Due care should be paid to the gravity center of loads and forklift to maintain the stability of the truck.

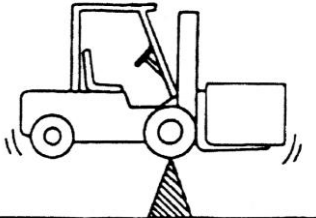



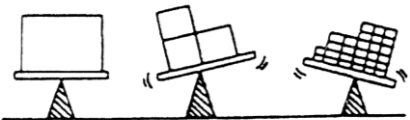

CAUTION **Load center**

There is difference in gravity because of the loads' shape, such as box, board and large roller. It is very important to distinguish the difference of the gravity center of loads for evaluating the truck's stability.



WARNING

If the truck will turn over, do not attempt to get out of the truck because the speed of overturn is much faster than your speed. You should hold the steering wheel handle, stretch your feet, and this practice will let you in the seats. Operator fastens the safety belt please.

 <p>Tilting</p>	 <p>Grab the steering wheel.</p>	 <p>Open your feet</p>	 <p>Don' t jump</p>
---	--	---	---

**CAUTION****The max. load and load center**

The load center distance is defined that: the distance between the load center and the fork carriage or the front of the fork carriage. The max. load means the maximum load the truck can charge at the normal load center distance. The relation between the max. load and load center distance shows on the capacity chart. You should reduce the weight of load if the load center distance inclines to the fork carriage.

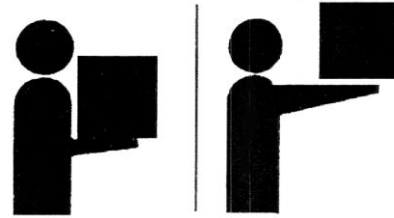
**CAUTION****Gravity center and stability**

The combined gravity center that is composed of the forklift center and the load gravity center determine the stability of lift trucks.

When unloaded, the barycenter does not change; when loaded, the barycenter is determined by the truck and the load's center.

The barycenter is also determined by the tilting and lifting of the mast.

The combined center is determined by these factors:

- Load's size, weight and shape
- The lifting height
- The tilting angle
- The acceleration
- The radius of turning
- The road and grade's angle
- The attachments

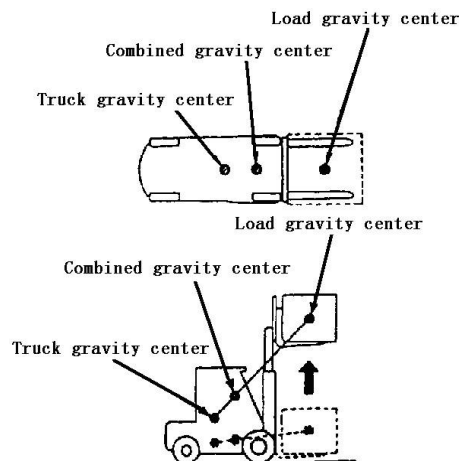
**CAUTION****The stable region of the load center**

In order to make the truck stable, the combined center must be in the triangle which is made up of two points that the two front wheels attach ground and the midpoint of the back axle.

If the combined center is in the front driving axle, the two front wheels become two fulcrums, the truck will overturn. If the combined center departs the triangle, the trucks shall overturn in the corresponding direction.

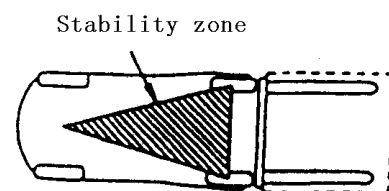

**CAUTION****Capacity chart**

The chart given shows the relation between the load center and the weight of loads.

Before loading, make sure that the load and the load center distance in the range of capacity chart. If the load's shape is complex, put the most weighty part on the middle of the forks, and close to the fork carriage.

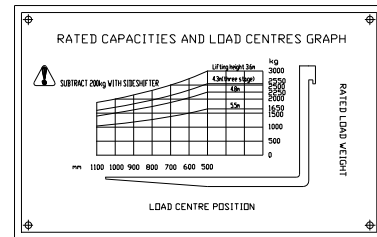
**CAUTION****Velocity and acceleration**

One object will keep quiescence until force works on it. Also, a moving object will keep moving until force works on it. This is just inertia.

According to inertia, when truck starts moving, one force works backwards, and when truck stops moving, one force works forwards. So, it's dangerous to brake suddenly, because it causes one large force works forwards, and it's easy to cause truck overturn or load slide off.

When the forklift makes a turn, will exert a centrifugal force outward from the curve center. This strength pushes forklift outwards and causes it to turn over. About stability region is very small, so decelerate when turning. If the cargo transported at the high position, it's easier to turn over.

8. Running-in of the new truck

We recommended operating the machine under light load conditions for the first stage of operation to get the most from it. Especially the requirements given below should be observed while the machine is in a stage of 100 hours of operation.

- Must prevent the new battery from over discharging when early used. Usually should recharge when discharging down to 20%.
- Perform specified preventive maintenance services carefully and completely.
- Avoid sudden stop, starts or turns.
- Oil changes and lubrication are recommended to do earlier than specified.
- Limited load is 70%~80% of the rated load.

9. Daily Maintenance

The earnest complete maintenance, can keep the forklift to be at the good status. And the safety of the truck is related with your job and your life.



WARNING

- Except checking lights and operating capability, you should shut off the key switch and pull out the plug before checking electric system.
- Prohibit operate forklift with trouble.
- Little trouble brings big accident.

1. Inspect oil leakage: include hydraulic oil, electrolyte and brake fluid

Inspect connector of the oil pipe and storage battery to see whether there is any leakage. Use your hand or eyes to inspect, Forbid to use a flame.

2. Inspect tire

Turn the tire valve cap counter clock-wise and move it. Using a tire pressure gauge, measure the inflation pressure, and adjusting it to the specified pressure, if needed. After making sure there is no air leakage from the tire valve, reinstall the cap. Check that each tire does not get damaged at the tread surface or side face. Make sure the wheel felloe is not bended.



WARNING

- Since the tires of forklift truck need have a high inflation pressure to carry heavy loads, even a small bending of rims or a little damage at the tread surface could cause an accident.
- When using an air compressor, at

first, adjust the air pressure of the compressor. Otherwise it will cause a serious accident, since the maximum pressure of compressor higher than the pressure tire can bear.

Tire Pressure

Only for the pneumatic-tire(GB/T2982-2001)

Model	Front wheel	Rear wheel
1.0t~1.5t	0.86 MPa	1.0 MPa
1.8t~little 2t	1.0 MPa	1.0 MPa
2.0t~5.0t	0.95 MPa	0.9 MPa

Replace tire



Warning

- When using an air compressor, first adjust the air pressure of the compressor. Failure to do so will cause a serious accident, since the compressor delivers the maximum pressure.
- To ensure safety, put the tire in a defend casing while inflating.

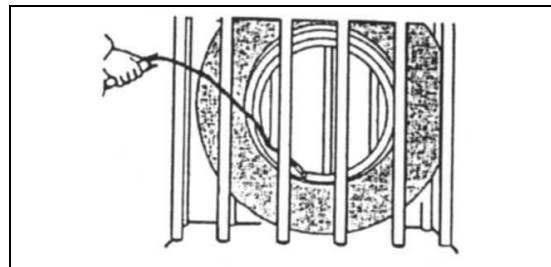

Front wheel

- ① Park forklift truck on level concrete;
- ② Start engine and raise mast about 100mm height.
- ③ Place chocks behind rear wheels to prevent movement of forklift;
- ④ Loosen wheel nuts 1-2 turns each by turning them counter-clockwise;
- ⑤ Tilt mast fully backward, and place a

wooden block under each side of outer mast;

⑥ Tilt mast forward until front wheels are raised from surface;



Caution

Do not loose nuts before the front wheels leave the ground.

⑦ Support truck by putting wooden blocks under both sides of the front truck frame. Stop the engine.

⑧ Take out the wheel nuts and replace the front wheel.



Caution

- a. When removing tire from wheel rim, do not remove rim set bolts and nuts before releasing air;
- b. Make sure that wooden blocks used to support lift truck are solid, one-piece units.
- c. Never get under forklift while it is supported only by wooden blocks.

⑨ Retighten the wheel nut temporarily.

⑩ Start the engine, and take out the wooden block.

⑪ Tilt backward the mast and lower down the mast slowly, then take out the wooden block under the outer mast and rear wheel.

⑫ Retighten the wheel nut with correct torque.

⑬ Adjust tire pressure to specified value.

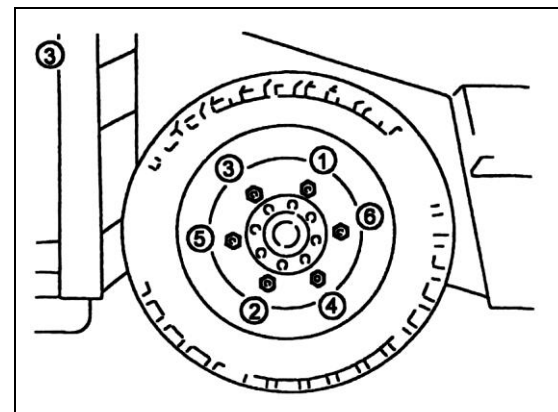
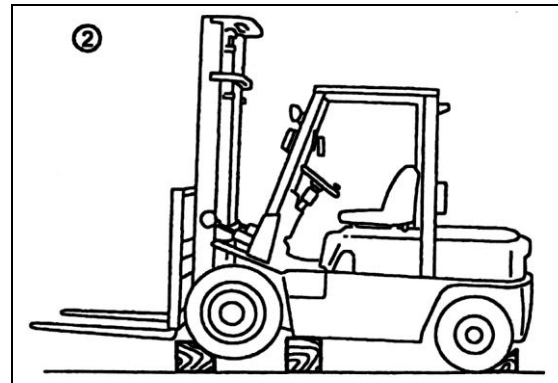
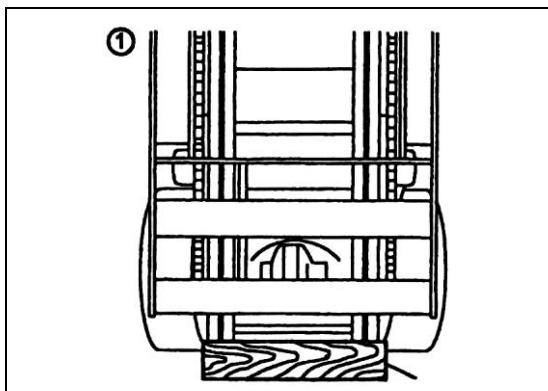

Rear wheel

① Park forklift trucks on level concrete.

② Pull the parking brake lever and place chocks before front wheels to prevent movement of forklift.

③ Put the lifting jack under the counterweight.

Caution: Make sure the jack capacity is greater than 2/3 of service weight of forklift.

④ Loosen wheel nuts 1-2 turns by turning them counter-clockwise.



Warning

Do not remove wheel nuts until rear tires are raised from ground.

⑤ Raise the forklift with jack until rear wheels off the ground. Support forklift truck by putting additional wooden blocks under both sides of the front truck frame as shown below.

⑥ Take out the wheel nut of rear wheel, and then replace the wheel.



Warning

- a. When removing tire from wheel rim, do not remove rim set bolts and nuts before releasing air;
- b. Make sure that wooden blocks used to support lift truck are solid, one-piece units;
- c. Never get under forklift while it is supported only by wooden blocks.

- ⑦ Retighten nuts as shown in figure below.
- ⑧ Remove the wooden block under chassis body. Let down the forklift slowly. Then take away the chocks and jack from the rear part of the front wheel.
- ⑨ Retighten the wheel nut with the correct torque. Please refer to *Tightening Torque Table*.
- ⑩ Adjust tire pressure to specified value.

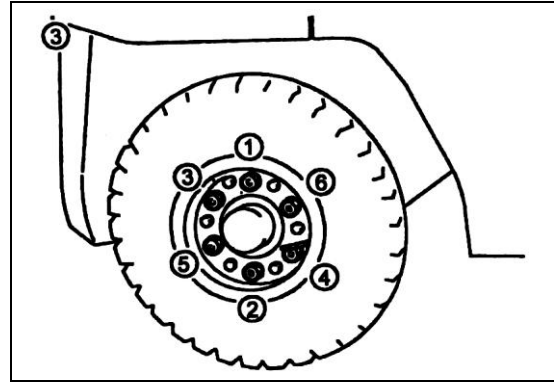
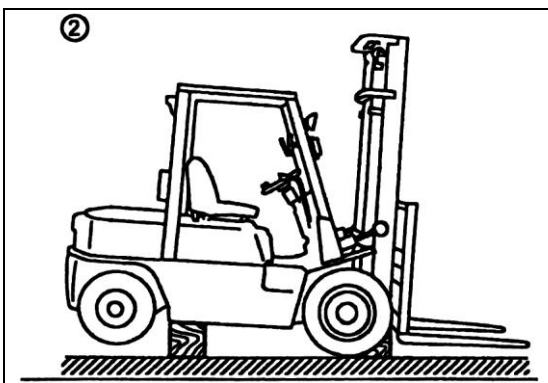
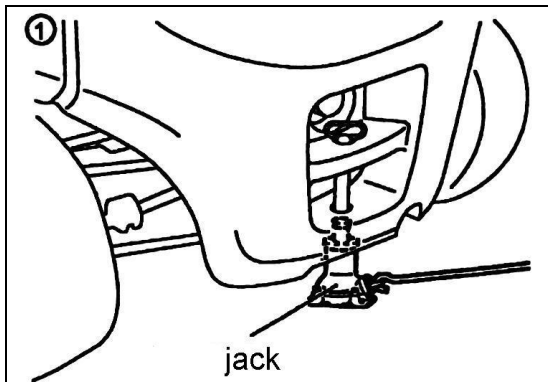

3. Checking the wheel attachments.

- Parking the truck securely.
- Tighten the wheel nuts crosswise with a torque wrench.

Bolt tightening torque:

Model	Front wheel nut (N.m)	Rear wheel nut (N.m)
1.0t~1.8t	157-176	76-107
2.0t~5.0t	441-588	157-176

Front wheel (Drive)



Rear wheel (Steering)



4. Check brake pedal

- Step the brake pedal, check it for slowness or block .

- The proper brake distance is 2.5m when free load .
- Adjust the height of pedal to 115~125mm .
- Adjust brake booster push rod clearance to 1-3mm .
- The brake lamp should be lighted when the brake pedal steps on 10-20mm .

5. Check the parking brake lever

The force of hand brake lever is adjusted by the bolt on the top of lever.

The force increases clock-wise screwing, and decreases counter lock-wise screw.



CAUTION

- To step the brake pedal is helpful to tighten or loose the hand brake lever.

6. Check accelerate pedal

The acceleration changes as the stroke changes.

7. Brake fluid level check

Open the brake lubricated cap cover. Check the fluid level in the range allowed. If lack, please add, and check if there is air mix into the pipe.



CAUTION

- Please use brake fluid with one type, do not mix.
- Don't spatter the brake oil onto the surface of paint otherwise the paint will be damaged.
- When adding fluid, due should be taken to prevent dirt or water from entering the reservoir.

8. Check hydraulic oil

Loose the cap of hydraulic oil inside of right frame, pull out dipstick and check it if the oil

level is between the scales. Add oil when lack.

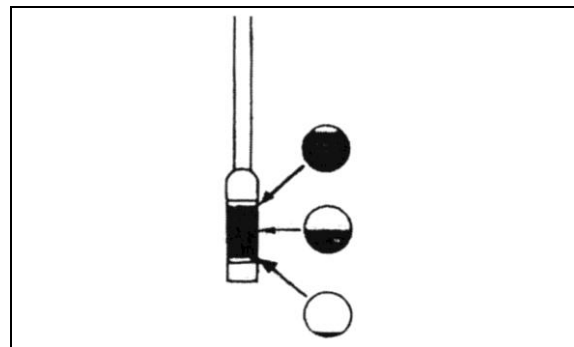

9. Replace hydraulic oil

Replace hydraulic oil once half year on schedule.

- Stop the truck on smooth ground.
- Turn steering wheel right to the bottom, and enable the fuel drain plug to have the enough space.
- Tilt mast backwards to the bottom, and fall the forks to the ground.
- Pull on the hand brake.
- Loose the cap of hydraulic oil, pull out dipstick.
- Set a plate under the chassis, then loose the fuel drain plug, and put the old oil.
- Dispose the old oil according to local environmental protection laws.
- Twist the fuel drain plug, join the new hydraulic fluid, and inspect whether have a leakage.
- Start the truck, lifting for 3-5 times, and tilting for 3-5 times.
- Add hydraulic oil to required scale.

10. Drivers seat adjustment

Make sure the driver's seat is properly located. If not properly, shift the adjusting lever to the right and move the driver's seat to a position which provides easy access to all foot and hand controls. After adjustment, shake the driver's seat a little to be sure that it is securely locked. Adjust the weight.

11. Check battery

- Check the battery whether be installed firmly.
- Check proportion of electrolyte. Refer to "Battery" section.
- Check the terminal for loose or damage. Otherwise it will be adjust or replace.

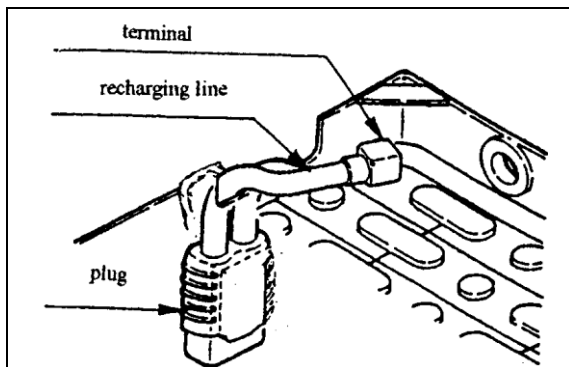

Pull in the plug and close the hood

Turn on the key switch

12. Instrument check (include battery capacity and error diagnose)

Refer to instrument section.

13. Lifting lever, tilting lever, attachment lever

Check the lifting lever, tilting lever and attachment lever for looseness. Return position well.

14. Mast

Check the mast and the forks to insure that:

- The fork does not have crack and distortion. Forks were installed firmly and correctly.
- Check the oil cylinder, oil pipes for leakage.
- Check the rotation of idler wheel
- Check the mast for crack or distortion
- Lifting lever, tilting lever, attachment lever
- Check the mast whether works normally, whether have unusual sounds.

15. Mast lubrication

You should grease lubrication to the orbit of mast on schedule base on requirement.

Adjust the lubricate schedule according to your working condition. Add times when busy.

To coordinate forklift's operation, grease lubrication to the guide pulley and in outer upright mounting.

16. Lift chain tension check

- Raise the fork about 10-15 cm above the ground vertically.
- Push the middle of the chain with the thumb. Make sure the tension for the right and left chains are equal.
- Adjust the chain tension: loosen the lock nut and adjust the chain by nut, then locked nut .

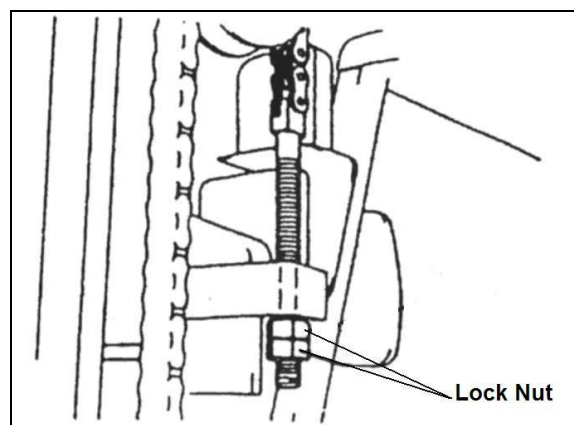
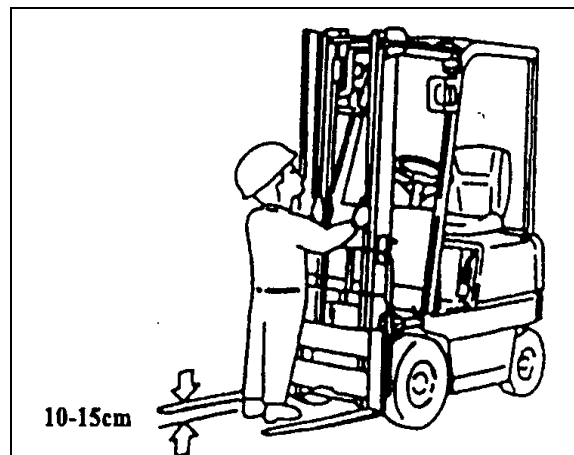

17. Check steering system

Turn the wheel right and left separately to check steering system.

18. Turn signal, horn and other lamp check

Make sure that the turn signal operates

properly by pull/push turn signal switch.

Make sure that the sound of horn is properly
by press the horn button

Check the other lamp and back-up buzzer.

19. Battery maintenance

Refer to battery section.

20. Other

For instance, pay attention to abnormal noise.

10. Driving and Operation

WARNING

- **Before operating the truck, check all controls and warning devices for proper operation. If any damage or fault is found, don't operate truck until corrected.**

Driving

- Open the cap, and insert the storage battery plug, then close the cap.

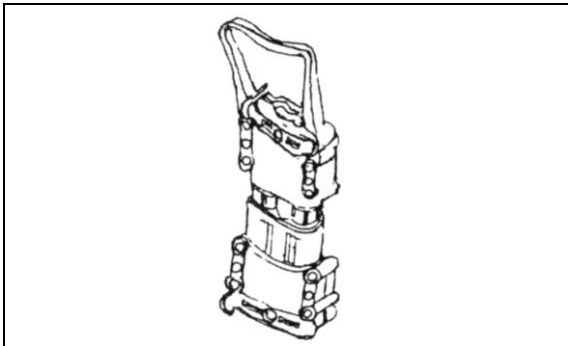

- Set the direction switch to neutral position .
- Turn on key switch .
- Hold the steering wheel with left hand and turn on the key switch with right hand.
- Tilt back the mast
- Control the lifting lever to set the bottom of the fork 100-200mm above the ground. Control the tilting lever to fully tilt back the mast.
- Control direction lever.
- Forward: Push the direction lever forward.
- Backward : Pull the direction lever backward.
- Loosen the hand brake lever
- Step the brake pedal and push the hand brake lever to the front position.
- Hold the steering wheel with your left hand and attach your right hand.

Traveling

Step the accelerate pedal slowly, the truck will travel forward or backward.

Decrease speed

Loosen the accelerate pedal slowly, the truck will decelerate.

CAUTION

Decelerate the truck in the situations following:

- **Turning;**
- **Close the goods or pallet;**
- **Close the deposit area;**
- **Enter a narrow passage;**
- **The condition of road surface is bad.**

WARNING

- **Don't step the accelerate pedal and brake pedal at the same time.**

Turning

Unlike general passenger-cars, the turning wheels are located at the rear of the truck. This cause the counterbalance swing out when turning.

Slow down the truck and turn the steering wheel toward the side which you are turning. The steering wheel should be turned a bit earlier than as with the front wheel steering car.

CAUTION

- **Drive the truck slowly and control the steering wheel carefully, assure there is enough space to steer.**

Stopping or parking

- Slow down and press the brake pedal to

stop the truck.

- Place the shift lever in neutral.
- Pull up the parking brake lever.
- Down the forks on the ground, tilt mast forwards fully.
- Place the key switch in "OFF" to shut off the battery. Remove the key and keep it.

! CAUTION

- Don't dismount from the moving truck, never jump from the truck.
- Don't parking the truck on the working road.

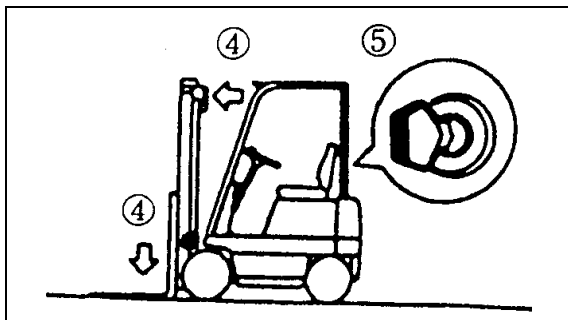

Loading

- The forks should be adjusted properly to maintain the balance of load.
- Place the truck right in front of the load to be handled.
- The pallet should be evenly positioned across both forks.
- Insert forks into the pallet as far as possible.
- To raise loads from the ground:
 - Firstly, lift the forks 5 to 10 cm off the ground or floor and make sure loads lay stably.
 - Then tilt the mast backwards fully and lift forks up to 15 to 20 cm off ground then start running.
- When handling bulky loads which restrict your vision, operate the truck in reverse

except when climbing grades.

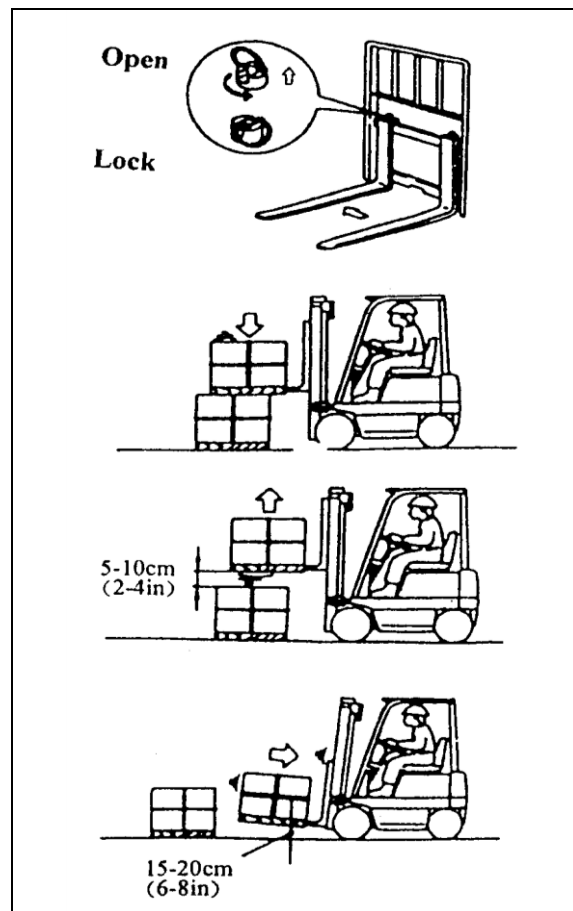

Stacking load

- When approaching the deposit area slow down your truck.
- Stop the truck right 30 cm far away from the position where your load is to be deposited.
- Check the condition of the deposit area.
- Tilt the mast forward until forks become to horizontal. Raise forks until they are a little higher than the deposit position.
- Move forward to place the load directly over the desired area and stop the truck.
- Make sure your load is just over the desired area. Slowly lower the load into position. Make sure the load is securely stacked.
- Do necessary lift-tilt operations and then back away to make the forks leave loads.

- After making sure the forks leave the load, lower the forks to the basic position (15 to 20 cm off the ground).
- Tilt the mast backwards.



CAUTION

Decelerate the truck in the situations following:

- **Turning;**
- **Close the goods or pallet;**
- **Close the deposit area;**
- **Enter a narrow passage;**
- **The condition of road surface is bad.**



WARNING

- **Never tilt the mast with loads upraised 2m or more.**
- **Don't leave or dismount from the truck when the load is raised high.**

Un-stacking load

- When approaching the area where the load is to be retrieved, slow down your truck.
- Stop the truck 30 cm far from the load.
- Check the condition of the load.
- Tilt the mast forward until forks become horizontal. Elevate forks up to the position of the pallet.
- Make sure forks are positioned properly to the pallet. Move forward slowly to insert forks into the pallet as far as possible.



CAUTION

- **If the forks are hard to be fully inserted, use the following procedure: Move forward and insert 3/4 of the forks. Raise the forks 5 to**

10 cm and move backward 10 to 20 cm with the pallet on the forks, and then fall the pallet to the stack.

- **Move forward again to insert the forks fully.**

- Raise the forks 5 to 10 cm off the stack
- Check all around the truck to insure that the path of travel is unobstructed and back away slowly.
- Lower forks to a height of 15 to 20 cm above the ground. Tilt the mast backward fully and move to the desired area.

Instructions for the Use of Parking Brake Switches

1. After starting, the instrument has P display. The brake coil loses power and the motor can't rotate.
2. When the seat switch is ON, press the brake button. The instrument has no P display. The brake coil loses power and the motor can't rotate. If the brake button is pressed again at this time, the instrument has P display. The brake coil loses power and the motor can't rotate.
3. If the seat switch is OFF at this time, trigger the brake delay; a. If the brake button is pressed within the effective range of the delay, the instrument has P display, the brake coil is out of power and the motor can not turn; only by pressing the brake button again can the brake be cancelled; B. If the seat switch is ON in the effective range of the delay, the delay is cancelled, and the instrument has no P. The display shows that the brake coil loses power and the motor can not rotate. C. If the delay is over, the seat switch is still OFF, the instrument has P display, the

brake coil is out of power, and the motor can not rotate; 4. When the seat switch is ON, the direction signal input, the accelerator signal input, the instrument does not display P, the brake coil gets electricity, the brake release, the motor can rotate; 5. When the brake button is pressed in the running process of the vehicle, the motor begins to decelerate to 0 immediately. When the speed of the motor falls below the parking start speed, the instrument shows P that the brake coil loses power and the motor can not rotate; only by pressing the brake button again, the brake can be cancelled. 6. Release the accelerator and trigger the brake delay when the motor speed falls below the parking start speed. a. If the direction signal input, accelerator signal input and seat switch are ON again in the valid range of delay, the delay will be cancelled. The instrument has no P display, the brake coil is energized, the brake is released, and the motor can rotate. b. If the brake button is pressed within the valid range of the delay, the instrument has P display, the brake coil loses power and the motor can not rotate; only by pressing the brake button again can the brake be cancelled; 7. At the end of the delay, the instrument has P display, the brake coil loses power and the motor can not rotate.

Check after operation

Clean and check the truck after operation:

- Damage or leakage.
- Add grease if necessarily.
- Check the tire if it is damaged or inset with

foreign body.

- Check the wheel hub nut if it is loose.
- Check the height of electrolyte surface.
- If you haven't lift the fork to the max. height in the day, you should lift it to the max. height 2~3 times.



CAUTION

- **If you find any trouble, must repair it in time.**
- **Prohibit operate the forklift before repairing it completely.**

11. Deposit

Daily Depositing

- Park your truck at the area appointed, and block the wheels to prevent accidental roll.
- Make sure the shift lever on neutral position.
- Pull up the hand brake lever.
- Shut off key switch and operate the lift and tilt lever several times so that the inner pressure in the hydraulic tube will decrease.
- Cramp out the electrical outlet.
- Take out the key and deposit it in a safe position.

Deposit the truck for a long time

On the basic of the “daily depositing” you should do these checks and maintenance additional:

- Take out plug to prevent discharge and place in shade.
- Brush antirust oil on those parts which is exposed such as piston rod and axle easy-rusted.
- Cover breather hole and so on which humidity easy to enter.
- Cover the whole truck with mantle
- All lubrication points add the oil (grease).
- Fill up the truck body and counter weight with stow-wood to reduce bearing of the two rear wheels.
- Operate the forklift once a week, and be required to lift the forks to its max. height many times .
- Check the proportion and the level of electrolyte once a month.
- Charge the battery equally once a month.



WARNING

- **The stow-wood must be single and hard enough to support the truck.**
- **Don't use a stow-wood higher than 300mm (11.81 inch) .**
- **Lift the truck to the height of placing on the stow-wood.**
- **Place two same size stow-woods under the left and right sides of the truck.**
- **After supporting the truck with stow-wood, swings the truck forward, backward, left and right, check its safety.**

Working after long deposit

- Get rid of antirust oil.
- Discharge the gear oil from driving axle, decelerator box, and clean up the internal of them. Add new oil.
- Charge the battery then install it to truck, and do not forget to connect the down-lead.
- Check carefully before starting, include start, advance, and back off, turning, lift, fall, tilt and so on.

12. Battery

Precautions for Battery Use:

1. Battery maintenance

It is important that the battery be properly charged in time, which will affect vehicle performance and battery life.

Over-discharge and over-charge will reduce battery life.

If there is abnormal situation such as odor, too fast electrolyte drop, high electrolyte temperature, please contact the agent or Hangcha after-sales service.

1.1 Maintenance precautions

(1) Maintenance personnel must undergo rigorous training.

(2) Never connect the battery's positive and negative terminals to each other, as this may cause a spark, fire or explosion. Fireworks, mobile phones and electronic products are strictly prohibited.



(3) Maintain and replace batteries and charge in designated well-ventilated areas, and place fire and power warning signs in conspicuous places.

(4) Check the electrolyte level daily. Do not use the truck when the electrolyte volume is low. Fill the distilled water (after charging) and always keep the electrolyte level at the specified height.

(5) The specific gravity of electrolyte was measured weekly.

(6) Make sure the battery surface is clean and dry. The connection terminals

should be kept clean and dry. Surface area water and dirt can cause automatic discharge.



(7) Tighten the vent cap and clear the small holes to prevent dust from entering the electrolyte.

(8) Measures in winter: Maintain a good charging environment. Do not park the truck out in the cold or in the freezer for long time especially after the battery is used, it is forbidden to put it in a low temperature environment below 0 °C.



Warning

1. It is forbidden to place metal components and any other objects on it, and it is forbidden to connect the two poles of the battery to avoid short circuit, spark, or even explosion.

2. The electrolyte contains sulfuric acid, which is highly corrosive. If it comes into contact with the body, it may cause burns. Wear goggles, rubber shoes and rubber gloves when handling. Contact with clothing: take off immediately. Contact with skin or eyes: flush with running water for 15 to 20 minutes. Accidental ingestion: drink plenty of water and see a doctor immediately.

3. Explosive gases are generated inside the battery, smoking, flames and sparks are prohibited. Mobile phones and other electronic products are prohibited. Otherwise, the battery will explode.

4. Use a damp cloth when cleaning (no dry cloth or fabric) to prevent static electricity.

1.2 Daily, weekly, monthly, long-term storage maintenance

Time	Content
Daily	<ol style="list-style-type: none"> 1. After the battery is discharged, it needs to be charged in time. 2. Check the electrolyte level. When the electrolyte level is low, add distilled water to the specified liquid level (after charging). If it is too high, it should be sucked out 3. Check if the vent cap is damaged. 4. Keep the battery surface clean and tidy. 5. Check whether the appearance is deformed, whether the surface is oxidized, stripped, whether the installation position is offset, whether the box is damaged or not.
Weekly	<ol style="list-style-type: none"> 1. The specific gravity of the electrolyte is tested and recorded. 2. Check if the small hole of the vent cover is blocked and dredged to prevent dust from falling into the battery. 3. Check if the battery stud bolt connection is loose (use torque wrench, torque is 25Nm). 4. Check if there is any fluid in the box and handle it.
Monthly	<ol style="list-style-type: none"> 1. Check whether the battery stud bolt is oxidized, whether the battery socket is damaged or deformed, or there is foreign matter. 2. Equalizing charge is performed once a month.
Long-term storage	The battery should be stored in a dry, ventilated place. Before storing the battery, fully charge it, and then charge it once every 30 days.

2. Specific gravity detection and conversion

The specific gravity of the electrolyte is tested at least once a week.

2.1 Specific gravity detection

- (1) Use a thermometer to measure the temperature of the electrolyte.
- (2) Vertically insert the flexible tube of a pipette-type density meter into the electrolyte and squeeze the bulb. Electrolyte will enter the glass tube and the float will rise up.
- (3) Take the density reading



Caution

Hold the density meter vertically so that the float does not touch the sides of the glass tube.

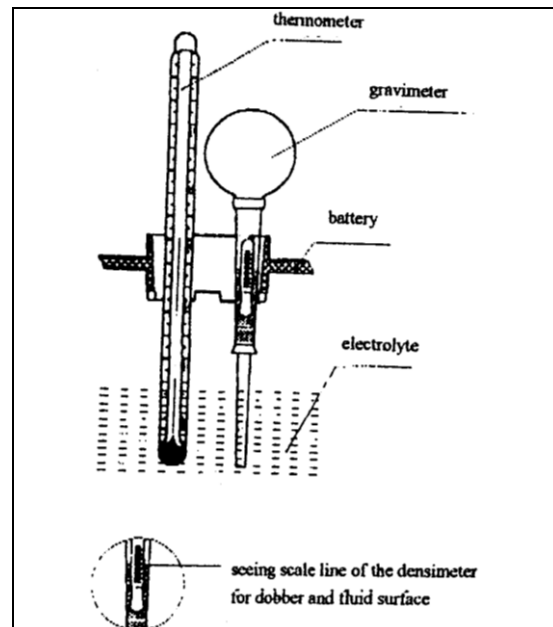

Use a hydrometer to measure the specific gravity of electrolyte.

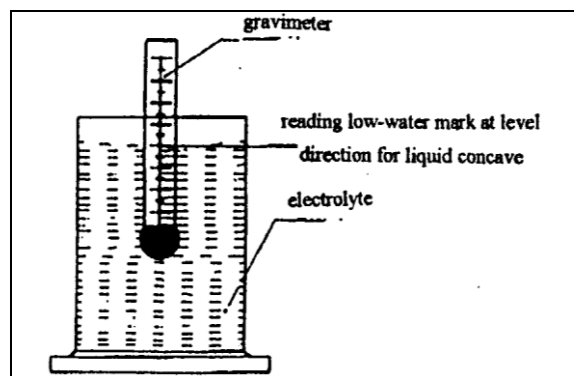

2.2 Specific gravity conversion

Convert electrolyte density at the standard temperature of 30°C based on the following formula:

$$D_{30} = D_t + 0.0007 (t - 30)$$

Wherein: D_{30} —electrolyte density at 30°C

D_t —measured electrolyte density at t°C.

t—electrolyte temperature during density measurement.

The specific gravity of the electrolyte mentioned in the manual refers to the specific gravity at 30 °C.

Specific gravity of the electrolyte varies with temperature.

Electrolyte after full charge: specific gravity 1.28 g/cm³

Electrolyte after 80% discharge: specific gravity 1.14g/cm³

3. Check the electrolyte level and add distilled water

Do not use the truck when the electrolyte is low.

Check the electrolyte level once a day. When the electrolyte level is low, add distilled water to the specified surface height (should be replenished after charging).

Warning

1. Using a battery when the electrolyte level is low may lead to overheating and shorten the life span of the battery.
2. When the amount of electrolyte is not correct, it will cause the battery to overheat and even burn the battery and electrical system components.

3.1 Check electrolyte level

Battery without hydrometer

Electrolyte is 15 ~ 20mm higher than

splashguard level.

Battery with hydrometer

Measure electrolyte level by reading the vent cap hydrometer.

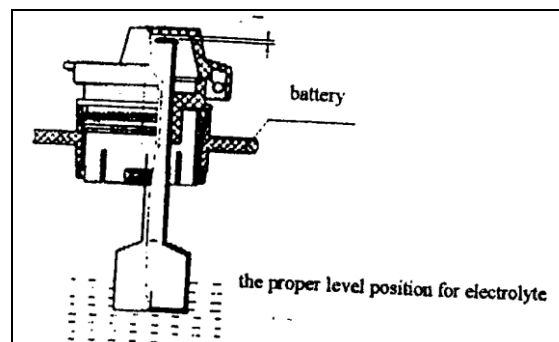
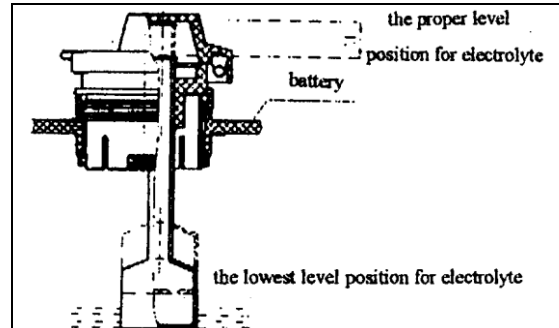

3.2 Topping up distilled water

After the charging is completed, distilled water should be added, and the liquid level is 15-20mm higher than protective screening (that is, in the middle position of the screen). But don't overdo it.

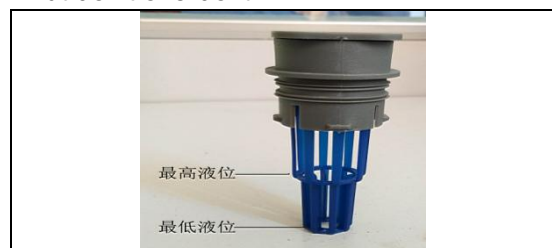

Procedures:

- (1) Wear protective eyewear, rubber boots and rubber gloves.
- (2) Fill a squeeze bulb pipette with a certain amount of distilled water.
- (3) Open all the vent or filler caps on the battery unit.
- (4) Inject distilled water into battery cells using squeeze bulb pipette.

Battery with hydrometer

Stop adding water when the red hydrometer float rises and a white line appears.

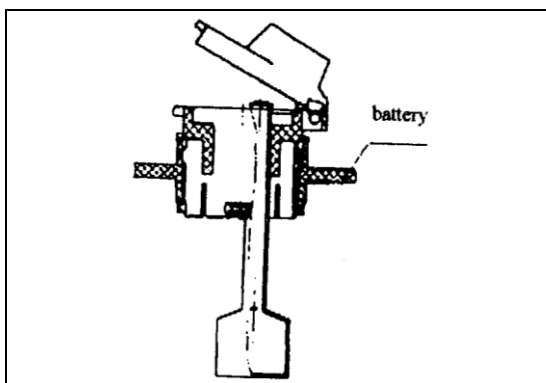
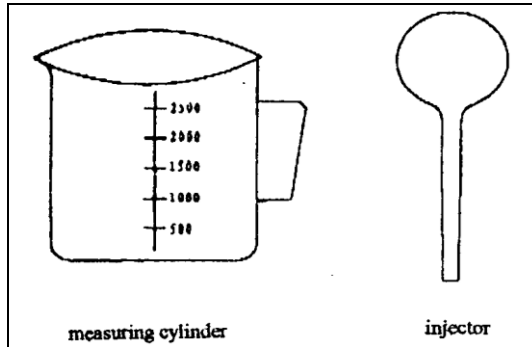

Battery without hydrometer

Stop adding water when electrolyte is 15-20mm higher than splashguard level.

(5) After topping up, tightly fasten the vent or battery caps.

(6) Use a damp cloth to wipe clean the surface of each battery cell.

(7) Use a squeeze ball pipette to draw off any excess water.

Warning

1. When adding distilled water, do not exceed the specified maximum level. Adding too much water may cause electrolyte leakage and damage the forklift when charging or discharging the battery.
2. Do not use a dry cloth or fabric to wipe the surface of the battery to prevent static electricity from causing an explosion.

4. Battery charging

Warning

1. The forklift should be charged as soon as possible after use. It must be charged in time before the battery is 20% left. Excessive discharge will shorten battery life.

2. Charge in a designated well-ventilated place, away from inflammable and explosive materials, and place a fire and electric warning sign in conspicuous places.

3. Open the forklift hood and battery vent cover while charging to completely release hydrogen. When charging the battery, it is forbidden to use an open flame, mobile phone or other electronic products to prevent explosion. Do not charge when thunder.

4. During the charging process, it is forbidden to suddenly turn off the power switch or unplug the battery, otherwise it will cause sparks and damage the plug and electrical components. Usually it is continuously and automatically filled.

5. After the charging is completed, distilled water should be added, and the liquid level is 15-20mm higher than protective screening (that is, in the middle position of the screen). But don't overdo it.

4.1 Charger requirement and selection

4.1.1 Charger

- (1) When the charger is in use, its casing needs to be reliably grounded.
- (2) Disconnect power when replacing fuse.
- (3) Only qualified professionals are permitted to disassemble the charger casing for testing or maintenance.
- (4) Do not rebuild or disassemble charger.

- (5) Take measures to prevent damage caused by charger overheating in high temperature season. If necessary, suspend work temporarily.
- (6) Never continuously charge multiple batteries, which will overheat the charger and may even damage it. After charging, let the charger rest for an hour before re-using it.

4.1.2 Charger selection

Choose charger according to battery voltage and capacity (see parameter list). Generally, the charger current is selected according to the middle value of the battery capacity (1/10 to 1/7), that is, the current = (1/10 to 1/7) battery capacity. For example, the battery capacity is 630Ah, the charger current = (1/10 ~ 1 / 7) 630 = 63A ~ 90A, the choice of 70A-80A charger is most suitable.

Please use the Hangcha pure charger.

4.2 Daily charging procedures

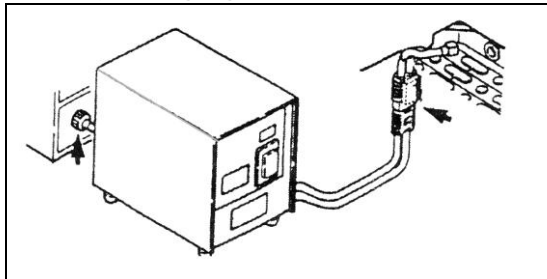

- (1) When the forklift meter shows 20% of the remaining power, it should be charged in time.
- (2) Turn off the forklift key switch and press the red emergency stop button.
- (3) Open the forklift cover and unplug the forklift cable from the battery socket.
- (4) Open the battery venting cover to release the explosive gas, and measure the temperature of the electrolyte. If it exceeds 45 °C, it needs to be naturally cooled to below 45 °C, and then charged. The electrolyte temperature during

charging should not exceed 55 °C.

- (5) Check if the charger plug and the battery socket are damaged. After checking the error, plug the battery into the charger plug. It is strictly forbidden to misconnect positive and negative poles.
- (6) Plug in the charger and press the charger's charging switch to charge.
- (7) After the charging is completed, the charging device is automatically powered off. Now disconnect the power of the charger and then unplug the charger.
- (8) Check the electrolyte level as required in the manual. If it is not enough, add distilled water (filled with Hangcha pure distilled water).
- (9) For those equipped with automatic water filling system, distilled water should be added according to the relevant parts of Operation and Maintenance Manual (Automatic Water Filling System of Battery (optional)).
- (10) Close the vent cover, clean the battery surface, and close the battery cover. Plug the forklift cable plug into the battery socket and the charging is completed.

4.3 Equalizing charge

4.3.1 Reason of equalizing charge

With time, the voltage, density and capacity of a battery tend to become unbalanced. The voltage and specific gravity of some cells increase more slowly compared with other cells when charging, and decrease at a faster rate when discharging.

Equalizing charge should be applied when any of the following situations occur:

- (1) The discharge voltage frequently falls

below the cut-off voltage;

(2) The discharge current is frequently too high;

(3) The battery is not charged in a timely manner after discharge is complete;

(4) The battery frequently gets insufficient charge, or hasn't been used for a long time;

4.3.2 Equalizing charge method

Please follow the instructions of the charger.

Set to equalizing charge mode and charge.

Equalizing charge is performed once a month.

5. Battery replacement



Caution

1. Before replacing a battery, make sure that the voltage, capacity, weight and dimensions of the new battery match the forklift specifications.

2. Do not use replacement batteries with a different voltage, weight or dimensions without the manufacturer's permission.

3. Lift the battery by attaching hooks to all 4 lifting holes. Do not lift with only 2 of the holes as this may subject the casing to uneven stress, causing the cells to rupture.

4. When lifting the battery box, do not touch the steering wheel or other equipment to avoid damage.

5.1 Replacement procedures

5.1.1 Storage battery

(1) Park the truck on the flat ground, and apply hand brake handle.

(2) Open the forklift cover

(3) Unplug the battery.

(4) Remove the lock pin.

(5) Lift the battery with a suitable lifting tool.

See 5.2 for weight.

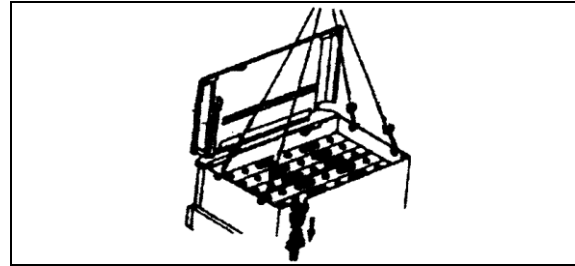

5.2 Battery weight and dimension

The battery replacement has the lightest and heaviest weight requirements, which is related to the stability of the forklift.

5.2.1 Battery weight and dimension of four-wheel electric forklift truck

Model	CPD10-XC4
Battery	CPD10-XD2
Allowable lightest	560 kg
Length×Width×Height	980 mm×465 mm×780 mm

Model	CPD15-XC4
Battery	CPD15-XD2
Allowable lightest	640 kg
Length×Width×Height	980 mm×465 mm×780 mm

Model	CPD18-XC4
Battery	CPD18-XD2
Allowable lightest	640 kg
Length×Width×Height	980 mm×465 mm×780 mm

Model	CPD20-XC4 CPD20-XD2 CPD20-XC4-JC
Battery	
Allowable lightest	800 kg
Length×Width×Height	1028 mm×571 mm×784 mm

Model Battery	CPD25-XC4 CPD25-XD2 CPD25-XC4-JC
Allowable lightest	900 kg
LengthxWidth xHeight	1028 mmx571 mmx784 mm

Model Battery	CPD45/50-XC4 CPD50-XXC4
Allowable lightest	1777 kg
LengthxWidth xHeight	1028 mmx855 mmx784 mm

Model Battery	CPD30-XC4 CPD30-XD2
Allowable lightest	1170 kg
LengthxWidth xHeight	1028 mmx711 mmx784 mm

Model Battery	CPD35-XC4 CPD35-XD2
Allowable lightest	1170 kg
LengthxWidth xHeight	1028 mmx711 mmx784 mm

Model Battery	CPD20-XXC4 CPD20-XXD2
Allowable lightest	900 kg
LengthxWidth xHeight	980 mmx465 mmx780 mm

Model Battery	CPD25-XLC4 CPD25-XLD2
Allowable lightest	1170 kg
LengthxWidth xHeight	1028 mmx711 mmx784 mm

Model Battery	CPD40-XC4
Allowable lightest	1500 kg
LengthxWidth xHeight	1028 mmx855 mmx784 mm

13.Lithium battery

1 Safety warning

- 1.1 Electrodes short circuit is prohibited, do not heat the battery, or throw the battery into water;
- 1.2 Fully charge the new battery before use;
- 1.3 Do not mix different brands, different types, different capacities, and old and new batteries;
- 1.4 The battery combination should not be used in the case of inconsistent capacity saturation of each single cell to avoid overcharge and over discharge of the cell;
- 1.5 Battery charging method should use professionally configured charging equipment, do not use charging equipment at will;
- 1.6 If the battery occurs odour, heating, discoloration, deformation or any abnormal phenomenon during use, storage or recharging, immediately remove it from the equipment or charger and stop using it. Please immediately contact our technician department or after-sales department;

2 The following operations are strictly prohibited

- 2.1 Do not put the battery near heat source, dangerous goods and hazardous material, such as fire, heater, corrosive chemical or hazardous machinery; store the batteries in cool, dry and well ventilated places if not used;
- 2.2 Do not immerse the battery in water or any other liquids, which may cause personnel injury or property loss;
- 2.3 Electrodes short circuit is prohibited. Avoid any metal or other conductive objects touching the positive and negative terminals of the battery. This operation may result in personal injury or property damage;
- 2.4 It is forbidden to transport or store batteries together with metals such as tools, cables, etc.
- 2.5 Do not hammer, throw or step on the battery;
- 2.6 Do not connect the battery with the battery of other type in series or in parallel; this operation may result in personal injury or property damage;
- 2.7 Do not operate the whole power system with lithium ion battery protection circuit board or battery management system in series or in parallel; This operation may result in personal injury or property damage. If needed, contact our technical department for correct technical support;
- 2.8 Do not let children or other person lacking of safety knowledge have access to the equipment. This operation may result in personal injury or property damage;
- 2.9 Do not disassemble, squeeze, puncture, storage at elevated temperature or bake the batteries. Violent vibration, impact and falls from heights should also be avoided. This operation may lead to security risks;
- 2.10 Do not operate the equipment in a location where static electricity and magnetic field is strong. Or it may damage safety protection device, and lead to potential safety hazard;
- 2.11 Do not recharge without proper protection device (lithium ion battery circuit board protection, BMS etc.) or with improper charging device (charger or DC power). This operation may result in personal injury or property damage.

3 Basic terms and environmental conditions for lithium ion battery

3.1 Basic terms and definitions

3.1.1 Nominal voltage

A suitable approximate value used to indicate the battery voltage;

3.1.2 Rated capacity

The capacity value specified by the manufacturer when the battery is fully charged under specified conditions;

3.1.3 Actual capacity

The capacity actually discharged when a fully charged single cell is discharged at a specified current under specified conditions:

3.1.4 Overdischarge

The state when the battery voltage is lower than the discharge cutoff voltage is generally regarded as the state in which the battery enters the overdischarge state, which generally refers to the state when the battery voltage reaches 0 V or even the voltage is negative;

3.1.5 Maximum charging voltage

The charging voltage recommended by the manufacturer that should not be exceeded during charging;

3. 1.6 Overcharge

The state when the battery voltage is higher than the maximum charging voltage is usually regarded as the battery entering the overcharge state;

3.1.7 Overcurrent

The battery's operation and charging current are higher than the maximum allowable operation of the manufacturer, and the state of charging current is usually considered as the battery entering the overcurrent state;

3.1.8 Normal temperature charge retention and capacity recovery capability

The battery is discharged at 0.3C after 28 days storage at $20^{\circ}\text{C}\pm 5^{\circ}\text{C}$. The ratio of discharge capacity to rated capacity is called normal temperature charge retention capability;

Then charged at 0.3C at $20^{\circ}\text{C}\pm 5^{\circ}\text{C}$, and then discharged to the termination voltage. The ratio of discharge capacity to rated capacity is called capacity recovery capability.

3.1.9 Charge termination current

The current at which the battery terminates charging during a specified constant voltage charge;

3. 1. 10 State of charge

The amount of electricity stored in the battery is generally expressed as a percentage. For example, 30% SOC means that the battery currently stores 30% of the nominal capacity. SOC is the abbreviation of State Of Charge, and the battery (group) is charged state;

3.1.11 Explosion

The battery casing is broken, and solid matter inside is flushed out of the battery and makes a sound;

3.1.12 Fire

Open fire appears in the battery case;

3.1.13 Leakage

The internal components of the battery (electrolyte or other substances) leak out of the reservoir;

3.1.14 Battery Management System (BMS)

An Electronic and electrical system monitors battery voltage, current, and temperature and communicates with other systems such as chargers, loads, thermal management systems, etc. through a series of control actions to optimize battery performance. BMS is the abbreviation of Battery Manager System.

3. 1.15 CAN communication: Control Area Network;

3.1.16 Charging mode CC/CV: CC mode is constant current charging mode, and CV mode is constant voltage charging mode.

3.2 Basic environment in use

3. 2.1 Charging temperature: $0^{\circ}\text{C}\sim 45^{\circ}\text{C}$; Discharge temperature: $-20^{\circ}\text{C}\sim 50^{\circ}\text{C}$; the best use temperature is $15^{\circ}\text{C}\sim 35^{\circ}\text{C}$;

3.2.2 When the ambient humidity HR is less than 85%, the battery should be kept as dry as possible;

3.2.3 When charging the battery, try not to fully charge or discharge, thus increase the battery life.

4 Cautions for use and maintenance of lithium ion battery

4. 1 Basic requirements for battery use

4.1.2 Under any circumstances, when testing or using the battery, the terminal voltage of the single battery must be tested in real time. It is strictly forbidden to test the battery pack in series without a management system or a protection board to avoid overcharging or overdischarging of the battery;

4.1.3 The new battery is generally only 50% charged. Please do not use it for a long time before the BMS and charger are commissioned, so as to avoid the truck being stopped due to insufficient battery power during use;

4.1.4 Battery management system: In order to ensure the safe and effective use of the battery and maximize the service life of the battery, the lithium battery product should be equipped with a dedicated power lithium battery management system (BMS) and a dedicated lithium battery charger, when a small number of small capacity batteries are used in series and in groups, you can also use a reliable lithium battery protection board. The Battery Management System (BMS) is as follows:

BMS parameter configuration	Overcharge protection voltage	3.75V
	Maximum charging current	200A
	Overcharge release voltage	3.67 V
	Undervoltage release voltage	2.8 V
	Undervoltage protection voltage	2.7 V
	Over-discharge protection voltage	2.2 V
	Over temperature protection temperature	60°C
	Over discharge release voltage	2.6 V

4.1.5 In the process of using the battery, it is strongly recommended to adhere to the principle of shallow charge and discharge. The best performance is between 30% and 100% of the power. When the open-circuit voltage of single batteries drops to 3.0V, the actual charge is less than 10%. At this time, the battery pack should be charged in time;

4.1.6 When testing or using the vehicle, always pay attention to the remaining battery capacity of the battery pack, and avoid using the trailer to transport the vehicle for charging when the power is exhausted. In the process of trailer, auxiliary systems such as DC/DC (power supply for lighting, wipers, etc.), steering power, brake power, etc. are still consuming power. Trailer for a long distance will also lead to battery overdischarge;

4.1.7 The high-voltage safety protection work of the battery pack must be well done. The drive main circuit and the low-voltage electrical circuit (including the vehicle body) must be properly isolated, and the reliable DC air circuit breaker and fast DC fuse should be selected;

4.1.8 It is strictly forbidden to separately draw power from the individual batteries in the battery pack to supply power to the low-voltage electrical equipment of the vehicle, so as to avoid the destruction of the consistency of the entire battery.

4.2 Basic requirements for lithium ion battery installation

4.2.1 The battery pack should be installed in the correct orientation. Do not reverse or reverse the installation.

4.2.2 Do not violently disassemble, and avoid personal and property losses.

4.3 Basic requirements for lithium ion battery connection

4.3.1 During the battery connection operation, be sure to pay attention to the correct port insertion;

4.3.2 Be careful during battery connection, avoid that the whole battery is reversed and shorted.

4.4 Basic requirements for storage and maintenance of lithium ion battery

The battery pack is stored in an incompletely charged state, typically around 40%. Product storage environment requirements are as follows:

4.4.1 Storage temperature: storage time <3 months, then stored at -40 ° C ~ 60 ° C, 40% SOC; storage time > 3 months, then stored at 0 ° C ~ 25 ° C, 40% SOC;

4.4.2 Storage humidity: 2% RH ~ 90% RH. Storage within 85% RH is recommended.

4.4.3 Storage environment: The product should be stored in a clean, ventilated and cool environment, and avoid direct sunlight, high temperature, corrosive gas, severe vibration, mechanical shock and heavy pressure; away from heat source; altitude is less than 1500 meters, atmospheric pressure is 86kPa~ 106kPa.

4.5 Basic requirements for lithium ion battery transportation

4.5.1 During the transportation of the battery, it is necessary to avoid exposure to sunlight for a long time and rain;

4.5.2 During the loading and unloading process, the battery should be handled gently to prevent falling, rolling, and heavy pressure;

4.5.3 During the process of transportation and use, the battery should be protected from strong impact and excessive extrusion, so as to avoid battery case or internal structural damage;

4.5.4 During the process of transportation and use, the battery should take necessary protection against the positive and negative electrodes of the battery to avoid short circuit and fire.

4.6 Preparation for lithium ion battery installation operation

4.6.1 Please read the instructions such as the battery instruction manual, battery installation operation and maintenance manual provided by our company;

4.6.2 Strict insulation treatment must be performed on tools such as socket wrenches, fixed

wrenches, and screwdrivers used for installation operations;

4.6.3 Wear anti-smashing shoes and insulated gloves when installing. Do not wear watches, metal bracelets, necklaces, etc.

4.7 Daily maintenance

- 1) There should be professionals when charging, make sure the plug and socket is well contacted, charging facility work normally, and each battery connections are well contacted. If abnormal, only charge after being repaired;
- 2) Check the vehicle dashboard before charging and discharging to ensure that all values are within the normal range;
- 3) When charging and discharging, avoid water or other conductive objects splash to the battery connector, for example, use when exposed to heavy rain. Before using the product, please read the product specification, instruction manual and use attentions to understand the use method and application range of the product. In the event of incorrect product use, incorrect connection of the circuit or the input power, load function and other parameters that do not conform to the performance parameters marked in the product specification are improper use. The company does not assume any responsibility for damage to products, loads and peripheral connections caused by improper use.

Cautions:

1. Charge the lithium battery immediately after per discharge to avoid battery loss;
2. Never place the battery near high temperature heat source, such as fire and heater etc.
3. Do not use the battery in a location where static electricity and magnetic field is great, otherwise the safety devices may be damaged, causing hidden trouble of safety;
4. Avoid using the battery under high temperature (direct sunlight) for a long time, otherwise, it may cause overheat of the battery or function invalid or service life being shortened;
5. Do not operate an electric vehicle equipped with a lithium battery in an environment where the temperature exceeds 55 °C; if the power battery system is below -25 °C, the power battery system needs to be self-heated to -10 °C to operate the vehicle.
6. Do not dismantle the battery box under any circumstance;
7. Never drop or knock the battery box etc.;
8. Short circuit of the battery is prohibited, never put any other object or tool to avoid battery short circuit;
9. Never wash battery box directly, prevent water getting into the battery and ensure the safety; it's forbidden to mix batteries of different brands, volumes and types;
10. Battery should be kept in a cool and dry place and avoid direct sunlight;

Maintenance instruction:

1. Do not change the battery setting parameter at will without the permission of the manufacturer;
2. If the lithium battery needs to interrupt or suspend charging, do not hot plug, avoid current arc to damage charging base;
3. Charging time below 0 °C will be longer than normal temperature charging time;
4. If the lithium battery is not used for a long time, it is necessary to charge and discharge the battery once a month.

5 Size and weight

Item	Long (L) (mm)	Width (W) (mm)	High (H) (mm)
CPD1015/18-XC4-I CPD1015/18-XD2-I	978	463	760
CPD20/25-XC4-I CPD20/25-XD2-I	1026	564	775
CPD30/35-XC4-I CPD30/35-XD2-I	1026	709	782
CPD20/25-XC4-JCI	1026	775	564
CPD20-XXC4-I CPD20-XXD2-I	978	463	760
CPD25-XLC4-I CPD20-XLD2-I	1026	709	782
CPD40/45/50-XC4-I CPD50-XXC4-I	1026	709	782

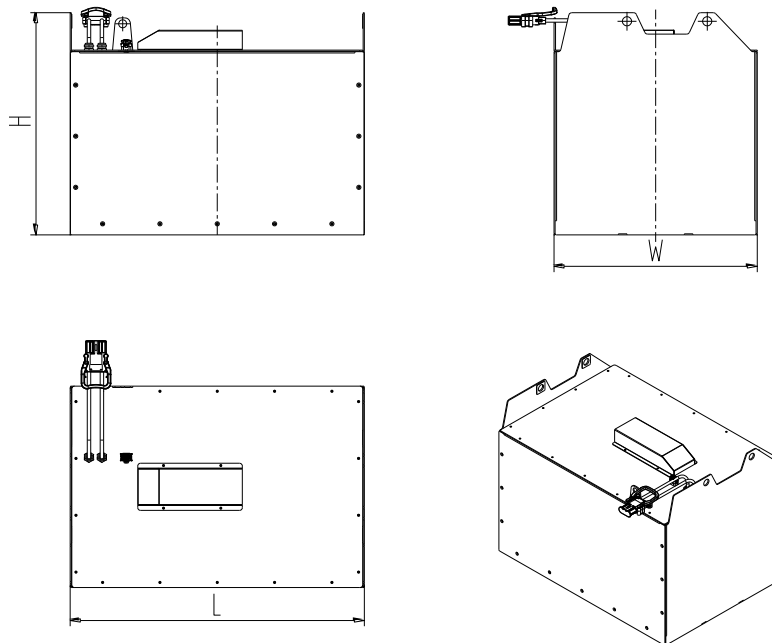

Warning

Weight and dimension of the battery has a great influence on the stability and bearing capacity of the truck travelling.

When installing or replacing battery, pay attention to the fixing position of the battery on the truck.

6.Lithium battery charging

This forklift truck is equipped with Titan can only charger.

3.0 t-5.0t and CPD25-XLC4-I with SLC-80200 smart charger, 1.5t~2.5t with SLC-48200smart charger, 1.0t with SLC-48100smart charger

Touch screen display interface

Start-up interface



Main interface

?	Wait for the charge	🔊
Battery BMS information	Charger information	Charger state
Voltage demand: V 99.9	Output U: V 99.9	<div style="display: flex; justify-content: space-around;"> <div style="text-align: center;">🔴 Work</div> <div style="text-align: center;">🔴 Hot</div> <div style="text-align: center;">🔴 CAN</div> <div style="text-align: center;">🔴 CV</div> <div style="text-align: center;">🔴 Bat</div> </div>
Current demand: A 999.9	Output I: A 999.9	<div style="display: flex; justify-content: space-around;"> <div style="text-align: center;">🔴 Fail</div> <div style="text-align: center;">🔴 Fan</div> <div style="text-align: center;">🔴 485</div> <div style="text-align: center;">🔴 CC</div> <div style="text-align: center;">🔴 BIS</div> </div>
CHG SOC limit: % 99.9	Charge T: M 99.9	Charger control
Residual cap.: % 99.9	Charge C: Ah 99.9	2015-07-16 12:23:34
Charging permit stop	Charge P: kWh 99.9	<div style="border: 1px solid gray; padding: 5px;">Mode switch</div> <div style="border: 1px solid gray; padding: 5px;">Turn on</div>

Click on the icon: , Enter the help description interface.

Click on the icon: or , on-off alarm sound, to turn on the alarm sound state, to turn off the alarm sound state.

The control operation requires password permission. **The default password is: 123456.**

Click on the boot icon: toggle charging control to turn on or off.

Click on the purple part of the charging status information bar, enter into the single charging module information display bar.

Click on the battery BMS battery bar to enter the detailed BMS information display bar.

Click on the mode switch, you can perform the normal mode booking mode switch.

Help interface.

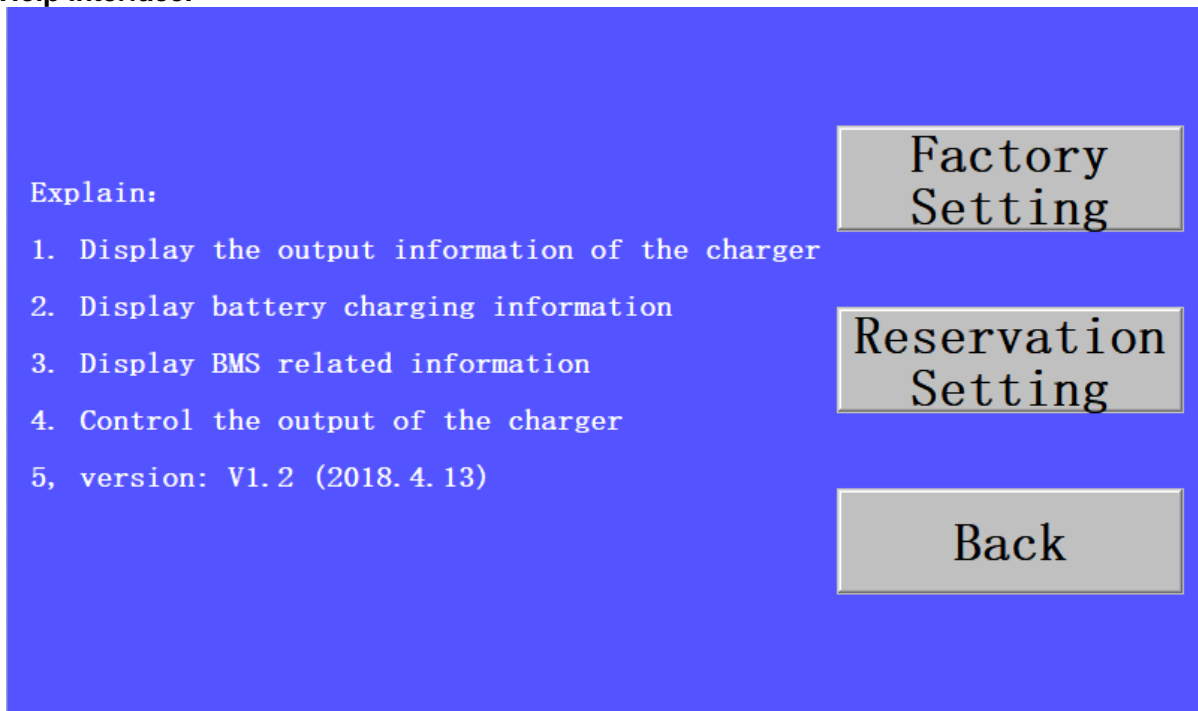

Click on the icon: , return to main interface.

Click on the reservation icon to set the time for booking mode. **The default password is 123456.**

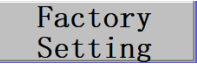
Click on the icon: , enter the password input interface, enter the correct password into the factory parameter setting interface .

Password entry interface (similar to operation password input interface)

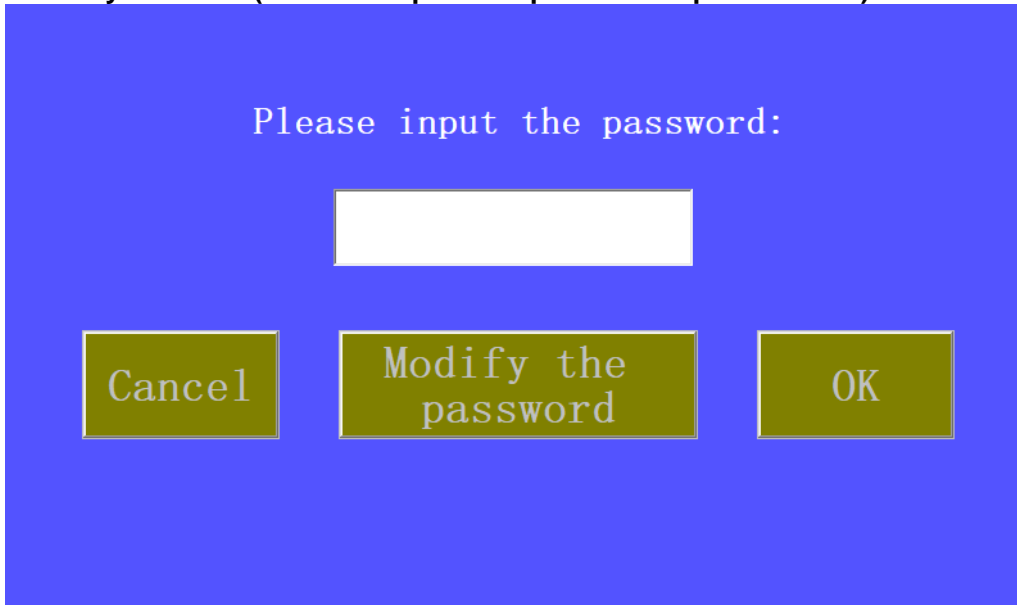

Enter the correct password in the password entry box. **The default password is 888888.**

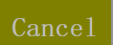
Click on the icon: , return to help description interface.

Click on the icon: , enter the password modify interface.

Click on the icon: , if the password is entered correctly, enter the parameter setting interface, otherwise the password input error is prompted. Please enter it again.

Password modification interface (similar to operation password modify interface)

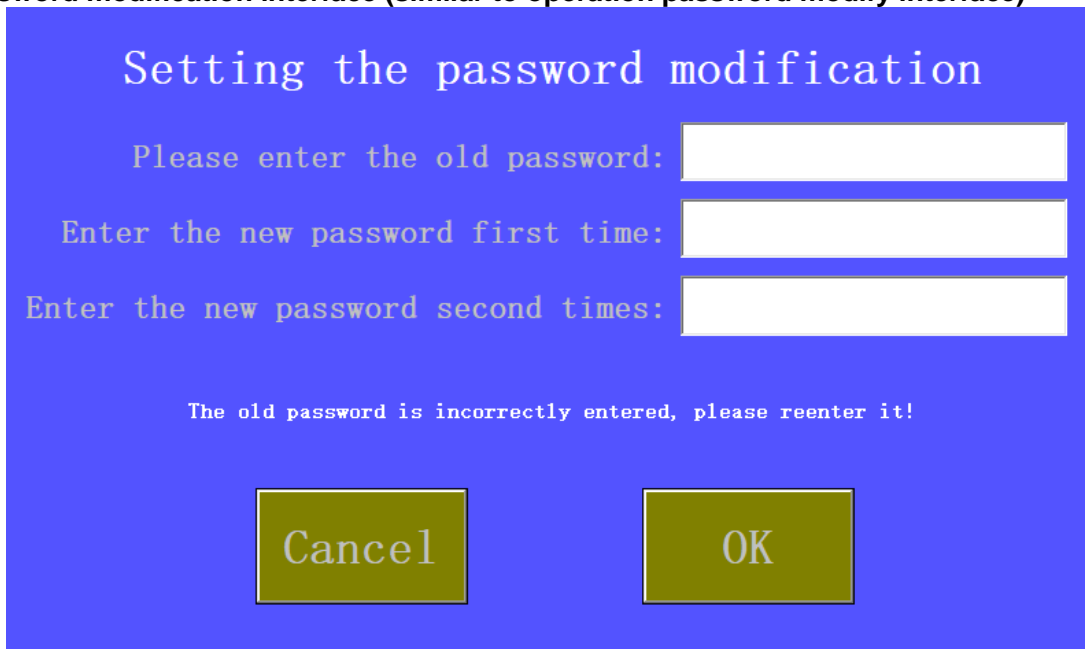



Enter in sequence according to the prompt: Enter the user's old password, enter the new password for the first time and enter the new password for the second time.

Click on the icon: , if the user's old password is entered correctly, the first time the new password is entered and the second time the new password is entered, the modification is successful. Otherwise, the prompt modification fails. Please re-enter.

Click on the icon: , Return to the password entry interface.

Parameter setting interface

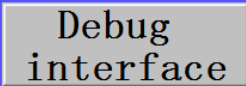
Parameter setting			
Charger number	1	Charge module number	2
Rated voltage: V	60	Limit voltage: V	60.0
Rated current: A	100	Limited current: A	100.0
Shunt range: A	500	Single rated current: A	100.0
Starting voltage: V	12.0	Allow charge SOC limit:%	100.0

Click on the icon: , return to the help description interface.

Parameter setting information: rated voltage, rated current and shunt range are related to machine hardware, and must not be arbitrarily modified after the factory.

Consult the manufacturer if the above parameters need to be modified. The charging machine number is easy for the user to distinguish, and the user can set it at will.

Debug interface for the factory to adjust the test, users can not operate at will.

Power module information display interface

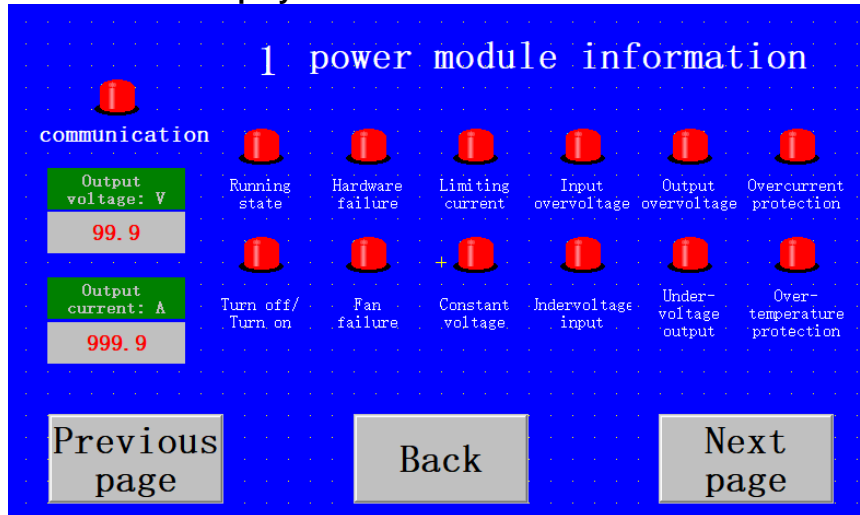

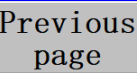
Click on the icon: , switch module information backward.

Click on the icon: , return to the main interface.

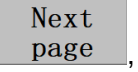
Click on the icon: , switch module information forward.

Display single power module output voltage, output current, various operating conditions.

Charging process explanation

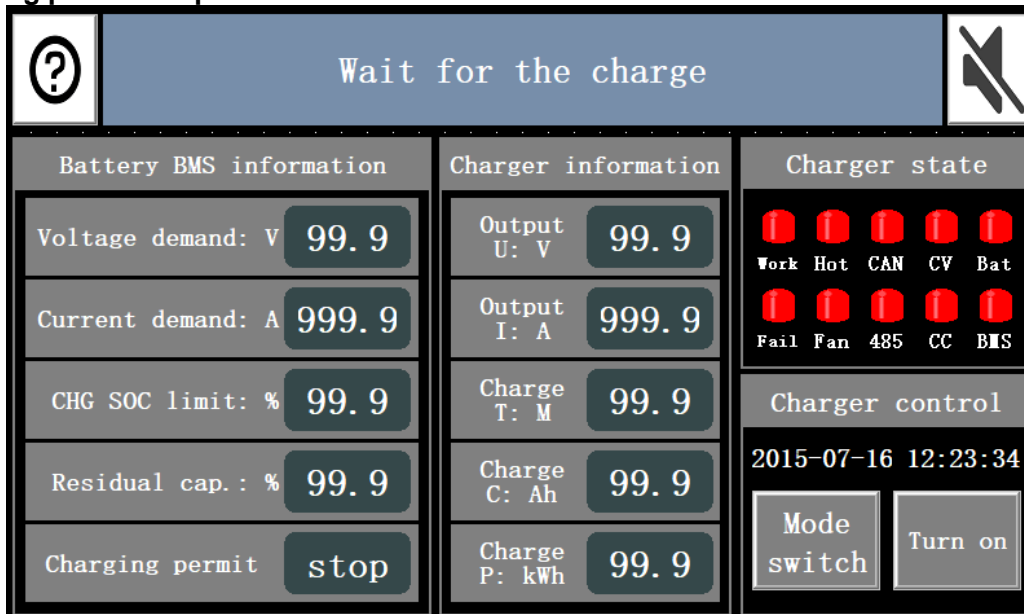

The charging step:

1. Choose "turn on" charging control mode. The "CAN" and "485" indicator lights are bright green.
2. DC charging gun and battery connection is normal.
3. "Residual capacity" is less than "allowed to charge the SOC limit" to start charging.
4. "Battery" indicator light is bright green (charging machine detected the battery voltage, this light), "BMS" indicator light green.
5. The "working" light is bright green. When the "output voltage" is similar to the "battery voltage", the charging motor outputs the relay to absorb and the charging machine officially begins to charge the battery. At this point, "output current" and "output voltage" will be output according to "current demand" and "voltage demand".

6. BMS charging complete, send charging termination command, charging motor end charging.

7. During the charging process, charging motor failure ("overheated "and" abnormal "lights of charging motor information are all charging motor failures), BMS charging or" charging allowed "in a prohibited state, and artificial charging control in a" stop "state, all will terminate the charging.

* In appointment mode, the charging machine will only work when the appointment time is set.

User wiring instruction

AC input air switch power supply.

Warning: PE protection of the earth must be connected, otherwise it may threaten life safety.

Operating instructions

1. Cautions

1) Before the charger is turned on, it should be checked whether the battery box wiring is correct, whether there will be a short circuit or a positive and negative electrode connection. To avoid overloading the charging machine and burning components or lines.

2) It can be put into use only after the charger has no abnormal, overheating and other warning information.

3) For the safety of charging machines and equipment, it is forbidden to directly disconnect the battery switch under the condition of output current, except in case of emergency.

2. Operation flow chart

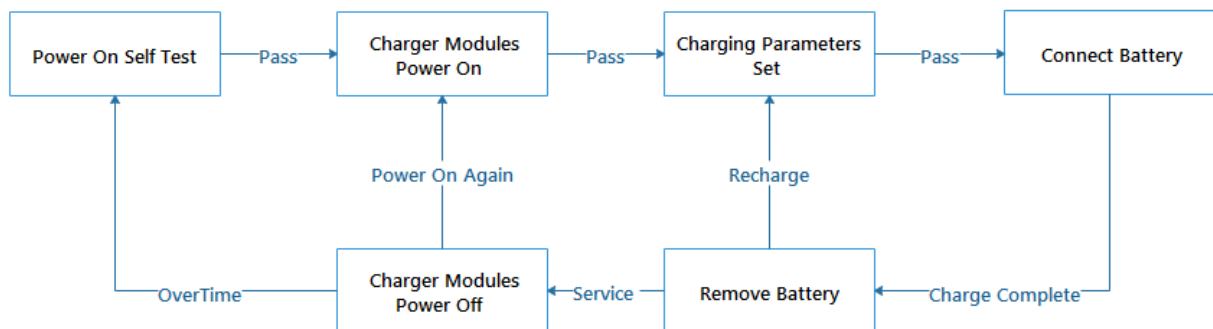

Concrete operation

1) Power check

Make sure that AC input zero wire and DC output positive and negative electrode wiring are correct, and that there is no short circuit in input and output; The input voltage and frequency are normal; At any time in the state of electricity.

Offline online charging lines can not be connected at the same time.

2) Power on

Check whether the AC fan wind direction is correct after the power is on.

The touch screen can be turned on normally, communication with the charging machine is normal.

3) Access to the battery

The battery voltage level and current level meet the requirements of the charging machine. Battery polarity is not reversed. Battery's fine. No abnormalities.

4) Power off

After the charging current and voltage drop to 0, exit the battery.

Turn off the AC input air switch.

Charging procedures:

1. Stop the forklift to the charging pile and turn off the key switch of the vehicle, that is, the vehicle is not charged.
2. Close the charger input main valve to make sure that the emergency stop switch bounces, the charging device is automatically turned on, the power indicator light is on, and the display interface starts automatically

 <p>输入电总阀 长期不用时请关闭总阀</p>	<p>Input main valve</p>
 <p>EMERGENCY STOP</p>	<p>Emergency stop switch</p>
	<p>Display interface</p>

3. Turn up the hood and check the lithium battery charging socket to ensure that there is no water or foreign matter in each port, and the metal terminal is not damaged or affected by rust or corrosion.



4. Connect the charging socket of the charger to the charging socket of the lithium battery, the charger will self-check and communicate with the lithium battery. When the entire system has no faults, about 15 seconds later, the internal relay of the charger will be switched on to start charging, the charging indicator will be on, and the meter will display Information such as charging voltage, charging current value, charging time and charging failure

5. When the lithium battery is fully charged, the charging device will automatically stop charging. At this time, the output voltage and output current of the meter are 0A. At this time, press the pause button, then press the charging gun lock and pull out the charging gun at the same time. If the lithium battery needs to stop charging when it is not fully charged, the pause button on the screen should be pressed first. After the charging current drops to 0 A, pull out the charging plug.



6. Remove the charger cable, put it at the charger, turn down the cover and lock it.

14. Maintenance summarization

- The fork lift truck needs inspection and maintenance periodically so as to make it in good working condition.
- Inspection and maintenance are usually ignored; you'd better find the problems and solve it in time.
- Use the orthodoxy spare part of HANGCHA GROUP CO., LTD.
- Don't use different oil when changing or adding oil.
- Forbid to repair the fork lift truck if you haven't been trained.
- Don't rave about oil and electrolyte used at will, and carry on handling according to the local environmental protection laws and regulations.
- Maintenance on schedule.
- After you make maintenance, you'd better make a record.
- **Truck modification by user, which can introduce hazards or risk not considered by manufacturers, will invalidate the existing truck risk assessments.**
Truck modification outside Europe is subject to regional requirements (see ISO/TS 3691-8).
- Only in the event that the truck manufacturer is no longer in business and there is no successor in the interest to the business, may the user arrange for a modification or alteration to a powered industrial truck, provided, however, that the user
 - a) arranges for the modification or alteration to be designed, tested and implemented by an engineer(s) expert in industrial trucks and their safety,
 - b) maintains a permanent record of the design, test(s) and implementation of the modification or alteration,
 - c) approves and makes appropriate changes to the capacity plate(s), decals, tags and instruction handbook, and
 - d) affixes a permanent and readily visible label to the truck stating the manner in which the truck has been modified or altered, together with the date of the modification or alteration and the name and address of the organization that accomplished those tasks.



CAUTION

- **No smoking.**
- **You should shut off key switch and pull off the plug before service(except some trouble shooting).**
- **Clean the electric part with compress air, do not with water.**
- **Do not place your hands, feet or any part of body into the gap between the mast and instrument.**

The weight of the counterweight:

Tonnage	Weight(Kg)
CPD20-XC4(-JC)、CPD20-XD2	650(+0~40)
CPD25-XC4(-JC)、CPD20-XC4-I CPD25-XD2、CPD20-XD2-I	1000(+0~40)
CPD30-XC4、CPD25-XC4-I、CPD25-XLC4-I CPD30-XD2、CPD25-XD2-I、CPD25-XLD2-I	1100(+0~40)
CPD35-XC4、CPD30-XC4-I CPD35-XD2、CPD30-XD2-I	1430(+0~40)
CPD15-XC4、CPD10-XC4-I CPD15-XD2、CPD10-XD2-I	530(+0~40)
CPD10-XC4、CPD10-XD2	340(+0~40)
CPD18-XC4、CPD15-XC4-I CPD18-XD2、CPD15-XD2-I	740(+0~40)
CPD35-XC4-I、CPD35-XD2-I	1816(+0~40)
CPD18-XC4-I、CPD18-XD2-I	740(+0~40)
CPD20-XXC4、CPD20-XXD2	915(+0~40)
CPD25-XLC4、CPD20-XC4-JCI CPD25-XLD2	650(+0~40)
CPD25-XC4-JCI	1000(+0~40)
CPD20-XXC4-I、CPD20-XXD2-I	1064(+0~40)
CPD40-XC4、CPD40-XC4-I	1300(+0~40)
CPD45-XC4	1460(+0~40)
CPD50-XC4、CPD50-XC4-I	2200(+0~40)
CPD45-XC4-I、CPD50-XXC4	1700(+0~40)
CPD20-XC4(-JC)、CPD20-XD2	650(+0~40)
CPD25-XC4(-JC)、CPD20-XC4-I CPD25-XD2、CPD20-XD2-I	1000(+0~40)

Preventive maintenance schedule

○ — Check, revise, adjust × — Replace

D—Daily; W—Weekly; M—Monthly; T—Trimonthly; S—Semiannually; Y—Yearly

Item	Service required	Tools	D (8 h)	W (40 h)	M (166 h)	T (500 h)	S (1000 h)	Y (2000h)
Lead-acid battery	Electrolyte level	Eyeballing	○	○	○	○	○	○
	Electrolyte proportion	Densimeter		○	○	○	○	○
	Battery quantity		○	○	○	○	○	○
	Terminal looseness		○	○	○	○	○	○
	Looseness of connecting wire		○	○	○	○	○	○
	Cleanness of the battery surface		○	○	○	○	○	○
	If there are tools on the battery.		○	○	○	○	○	○
	The tightness and smoothness of air cap			○				
	Far away from firing		○	○	○	○	○	○

Controller

Item	Service required	Tools	D (8 h)	W (40 h)	M (166 h)	T (500 h)	S (1000 h)	Y (2000h)
Controller	Check connector for worn					○	○	○
	Check contactor for running					○	○	○
	Check micromove switch for running					○	○	○
	Check the connection among motor, battery and power unit.					○	○	○
	Check the controller error diagnose system							First time 2 years

Motor

Item	Service required	Tools	D (8 h)	W (40 h)	M (166 h)	T (500 h)	S (1000 h)	Y (2000h)
Motor	Clean the foreign body on the motor				○	○	○	○
	Clean or replace the bearing						○	○
	Check the carbon brush and commutator for worn, whether spring is normal				○	○	○	○
	Whether the connection is correct and firm.				○	○	○	○
	Brush carbon powder on shift plate and shift device.					○	○	○

Driving system

Item	Service required	Tools	D (8 h)	W (40 h)	M (166 h)	T (500 h)	S (1000 h)	Y (2000h)
Heck wheel hub bolts for tighten torque	Check for noise		○	○	○	○	○	○
	Check for oil leaks		○	○	○	○	○	○
	Change oil						×	×
	Check wheel hub bearing for looseness,noise			○	○	○	○	○
	Clean and replace grease					×	×	×
	Leakage check		○	○	○	○	○	○
	Check wheel hub bolts for tighten torque				○	○	○	○

Wheels (Front, Rear Wheels)

Item	Service required	Tools	D (8 h)	W (40 h)	M (166 h)	T (500 h)	S (1000 h)	Y (2000h)
Tyre	Check for charge pressure	Barometer	○	○	○	○	○	○
	Check for abrasion, cracks or damage		○	○	○	○	○	○
	Check for spikes, stones or foreign matter				○	○	○	○
	Check the wheel hub for damage		○	○	○	○	○	○
	Check the split body wheel hub-bolts for looseness	Test hammer	○	○	○	○	○	○

Steering System

Item	Service required	Tools	D (8 h)	W (40 h)	M (166 h)	T (500 h)	S (1000 h)	Y (2000h)
Steering wheel	Check for clearance		<input type="radio"/>	<input type="radio"/>	<input type="radio"/>	<input type="radio"/>	<input type="radio"/>	<input type="radio"/>
	Check for radial looseness		<input type="radio"/>	<input type="radio"/>	<input type="radio"/>	<input type="radio"/>	<input type="radio"/>	<input type="radio"/>
	Check for axial looseness		<input type="radio"/>	<input type="radio"/>	<input type="radio"/>	<input type="radio"/>	<input type="radio"/>	<input type="radio"/>
	Check for operation		<input type="radio"/>	<input type="radio"/>	<input type="radio"/>	<input type="radio"/>	<input type="radio"/>	<input type="radio"/>
Steering Gear box and valve	Check mounting bolts for looseness				<input type="radio"/>	<input type="radio"/>	<input type="radio"/>	<input type="radio"/>
Steering axle	Check king pins for looseness or damage				<input type="radio"/>	<input type="radio"/>	<input type="radio"/>	<input type="radio"/>
	Check for deflection, deformation ,cracks or damage				<input type="radio"/>	<input type="radio"/>	<input type="radio"/>	<input type="radio"/>
	Check for fixing condition	Test hammer			<input type="radio"/>	<input type="radio"/>	<input type="radio"/>	<input type="radio"/>
Steering cylinder	Check for operation		<input type="radio"/>	<input type="radio"/>	<input type="radio"/>	<input type="radio"/>	<input type="radio"/>	<input type="radio"/>
	Check for oil leaks		<input type="radio"/>	<input type="radio"/>	<input type="radio"/>	<input type="radio"/>	<input type="radio"/>	<input type="radio"/>
	Check for looseness when fixing or hinging				<input type="radio"/>	<input type="radio"/>	<input type="radio"/>	<input type="radio"/>

Brake system

Item	Service required	Tools	D (8 h)	W (40 h)	M (166 h)	T (500 h)	S (1000 h)	Y (2000h)
Brake pedal	Check for free travel	Scale	○	○	○	○	○	○
	Check for pedal travel		○	○	○	○	○	○
	Check for operation		○	○	○	○	○	○
	Check for air mixed in brake piping		○	○	○	○	○	○
Parking brake	Check for lever is securely locked and has sufficient lever stroke		○	○	○	○	○	○
	Check for operation		○	○	○	○	○	○
Rod, Cable, etc	Check for operation				○	○	○	○
	Check connections for looseness				○	○	○	○
	Check decelerator connector lug for abrasion					○	○	○
Hoses and Pipes	Check for damage, leakage or collapse				○	○	○	○
	Check connection or clamping parts for looseness				○	○	○	○
Brake master cylinder and wheel cylinder	Check for leakage		○	○	○	○	○	○
	Check for fluid level, Change brake fluid		○	○	○		×	×
	Check master cylinder and wheel cylinder for operation					○	○	○
	Check master cylinder and wheel cylinders for fluid leaks or damage					○	○	○
	Check master cylinder piston cup, and check valve for wear or damage change						×	×

Hydraulic system

Item	Service required	Tools	D (8 h)	W (40 h)	M (166 h)	T (500 h)	S (1000 h)	Y (2000h)
Hydraulic reservoir	Check for oil level, Change oil		○	○	○	○	×	×
	Clean suction strainer						○	○
	Clean foreign matter						○	○
Control lever	Check levers for looseness		○	○	○	○	○	○
	Check for operation		○	○	○	○	○	○
Control valve	Check for oil leak		○	○	○	○	○	○
	Check relief valve and tilt lock valve for operation				○	○	○	○
	Measure relief pressure	Oil press gauge					○	○
Hose, Piping Hose Reel & Swivel Joint	Check for oil leak, looseness, collapse, deformation and damage				○	○	○	○
	Replace hoses.							× 1-2 years
Hydraulic Pump	Check hydraulic pump for oil leak or noise		○	○	○	○	○	○
	Check pump drive gear for wear				○	○	○	○

Lifting system

Item	Service required	Tools	D (8 h)	W (40 h)	M (166 h)	T (500 h)	S (1000 h)	Y (2000h)
Chains & Sheave	Check chain for tension, damage or rust		○	○	○	○	○	○
	Add lubrication for chains				○	○	○	○
	Check connection of chain anchor pin and chain for looseness				○	○	○	○
	Check sheaves for deformation or damage				○	○	○	○
	Check sheave bearings for looseness				○	○	○	○
Attachment	Perform general inspection				○	○	○	○
Lifting cylinder and tilting cylinder	Check piston rod, rod screw and connection for looseness deformation or damage	Test hammer	○	○	○	○	○	○
	Check cylinders for operation		○	○	○	○	○	○
	Check for oil leak		○	○	○	○	○	○
	Check pins and cylinder bushings for wear or damage				○	○	○	○
Fork	Check forks for damage, deformation or wear				○	○	○	○
	Check for stopper pins for damage or wear					○	○	○
	Check fork base and hook welding for defective cracks or wear				○	○	○	○
Mast & Lift Bracket	Check weld between cross members with outer and inner masts for defective, cracks or damage				○	○	○	○
	Check tilt cylinder bracket and mast for defective weld ,cracks or damage				○	○	○	○
	Check outer and inner masts for defective weld, cracks or damage				○	○	○	○
	Check for defective weld, cracks or damage of lift bracket				○	○	○	○
	Check roller bearings for looseness				○	○	○	○
	Check mast support bushings for wear or damage						○	○
	Check mast support cap bolts for looseness	Test hammer			○ (for 1st time)		○	○
	Check lift cylinder tall bolts, piston rod head bolts, U-bolts, and piston head guide bolts	Test hammer			○ (for 1st time)		○	○

	for looseness							
	Check rollers, roller pins and welded parts for cracks or damage				○	○	○	○

Others

Item	Service required	Tools	D (8 h)	W (40 h)	M (166 h)	T (500 h)	S (1000 h)	Y (2000h)
Overhead Guard & Load Backrest	Check for tight installation	Test hammer	○	○	○	○	○	○
	Check for deformation, cracks or damage		○	○	○	○	○	○
Turn signal	Check for proper operation and tight installation		○	○	○	○	○	○
Horn	Check for proper operation and tight installation		○	○	○	○	○	○
Light & Lamps	Check for proper operation and tight installation		○	○	○	○	○	○
Buck-up Buzzer	Check for proper operation and tight installation		○	○	○	○	○	○
Meters	Check meters for proper operation		○	○	○	○	○	○
wire	Wire damage or looseness			○	○	○	○	○
	Looseness of Electric circuit Joint				○	○	○	○

Replace the key safe parts termly

- Some parts should be checked periodically to detect the damage, for improving the safety, users should replace the parts periodically which are listed in the table as follows.
- If the parts are abnormal before the replacing time is coming, it should be replaced immediately.

Key safe part's description	Term of using (year)
Brake hose or tube	1~2
Hydraulic hose for lifting system	1~2
Lifting chain	2~4
High-pressure hose , hose for hydraulic system	2
Brake oil cup	2~4
Brake master cylinder, brake slave cylinder cover and dust sleeve	1
Inner hermetic, rubber matter	2
Rubber pad of the steering axle	4

Table for oil used in the truck

Name	Trademark, code name	Capability	Remark
Hydraulic oil	Normally: L- HM32 Cold environment :L-HV32	35 L	1.0t~3.5t
		45 L	4.0t~5.0t
Gear oil	GL-5 85W/90 (Cold environment Cold storage forklift: GL-5 80W/90)	4.5 L	1.0t~1.8t
		6 L	2.0t~3.5t
		8 L	4.0t~5.0t
Brake Fluid	(Choice) HZY3 or DOT3	0.6 L	1.0t~3.5t
		1.0 L	4.0t~5.0t
Industrial Vaseline	2#		Electrode of storage battery
Lubrication grease	Automobile general lithium base lubricant		

Table for bolts tightening torque

Unit: N·m

Bolt's diameter	Grade			
	4.6	5.6	6.6	8.8
6	4~5	5~7	6~8	9~12
8	10~12	12~15	14~18	22~29
10	20~25	25~31	29~39	44~58
12	35~44	44~54	49~64	76~107
14	54~69	69~88	83~98	121~162
16	88~108	108~137	127~157	189~252
18	118~147	147~186	176~216	260~347
20	167~206	206~265	245~314	369~492
22	225~284	284~343	343~431	502~669
24	294~370	370~441	441~539	638~850
27	441~519	539~686	637~784	933~1244

Note:

- Use entirely 8.8 grade bolt in the important joint position.
- Bolt's grade can be found in the head of the bolt, if it can't be found, the grade is 8.8.

15.The use, Install and Safety Rules of attachment

HANGCHA will choose attachment that according with International standard ISO2328 《Forklift pothook fork and install size of carriage》,such as clamp, rotator, paper roll clamp, carrying ram, side-shifter ect.

Attachment assy

- **Untempered technology licence of our company, any refit at safety and capability to attachment is strict prohibit.**
- **Fact rating load capacity should be the least of rating load capacity, the load capacity of attachment, colligate load capacity of truck. Generally speaking, the colligate load capacity of truck is the least. Attachment load capacity just a count value of attachment pressure.**
- **Assy go to in reason, credibility, safety to avoid the attachment glide around carriage in using.**
- **After hang attachment, embed the rise catch block to the gap of top beam, let the offset of centre line of attachment and carriage is less than 50mm.Otherwise,it will be affect the landscape orientation stability of forklift.**
- **To these attachment with rotating function, such as paper roll clamp, bale clamp, muti-purpose clamp, drum clamp, it needs to weld chock block in the joint of carriage beam and attachment to prevent move from side to side in the operation.**
- **Assy the attachment of below catch orientation, it need to adjust the clearance between below catch and beam of carriage.**

Attachment use

- Know well the content of nameplate on attachment, read the instruction manual before
- Usage.(Especially the manual from attachment company)Before operate the attachment, the people should be trained and obtain the qualification.
- It should be understand the basic capability and operate methods of attachment. Especially the admit load, lift height, size of cargo and adapt range of attachment.
- Operate the multi-functional attachment, such as with side-shifter, clamp or rotator, it is not allowed that two action at one time. Operate one functional then do another one.
- Prohibit the cargo at a high position when truck move with attachment. If the size of cargo is too big, prohibit the truck move on. Transport the cargeo, make sure that the distance of bottom of cargo and ground is less than 300mm and mast incline back.
- The weight of cargo couldn't exceed the limited value of combination carrying capacity of forklift and attachment. It is not allowed that partial load at high position. It is a short time work for attachment with side-shifter. Partial load is around 100mm (Above 5 ton (including 5 ton),the side-shifter movable within 300mm.
- In the range of the projection forth 2m of the lower of attachment and cargo, prohibit stand to

avoid the suddenness except the driver position under overhead.

- It is not allowed that an emergency brake in moving. Run slowly with load.
- Prohibit outside force when attachment working.
- It couldn't be use at malfeasance situation and overstep normal work range.
- When the attachment failure, prohibit use without check.

Check and maintenance:

- Check the clearance of carriage beam and below catch of attachment if accord the attachment manual.
- Check the rise catch is right on the flute of fork carriage.
- Use the auto currency lithic-grease per 500 hours to bearing surface.
- If the tighten firmware become flexible.
- Check the tie-in of hydraulic pressure loop, if tube attaint. Prohibit use after repair.
- Check the drive of attachment timing or turn the component if fray or block, change betimes.
- Check each element if in normal under load attachment is work in gear. If not, check the hydraulic pressure loop, find out the broken part, change air poof or whole loop part.

16. Battery automatic filling water system(Optional)

Makeup of the automatic filling watering system:

- Automatic Watering Plug
- End Plug
- Floater
- T-piece & L-piece
- Flow Indicator (with filter)
- 6mm, 8mm ,10mm watering pipe
- Male & Female couplings (Kv10 and KV6, etc.)
- Water Tank



Application specification and installation

During the period of development and long-term practical usage, the leak tightness of automatic watering system has received complete recognition.

But when you use it, you need to keep the automatic watering system clean and there can't be any filth on the surface.

How to properly install the automatic watering system: Our automatic watering system is easy to operate, no need to finish watering the electrolyte in the storage battery by hand, time saving and labor saving, besides, it can extend the service life.

How to correctly install the water tank, choose proper floaters, how to confirm the specification & quantity of the installed accessories according to different types of battery, including correct application rules for automatic watering plug, watering pipe, T/L-pieces and male/female couplings as well as the cleaning of the flow indicator. We will give you a brief introduction for the above items as follows:

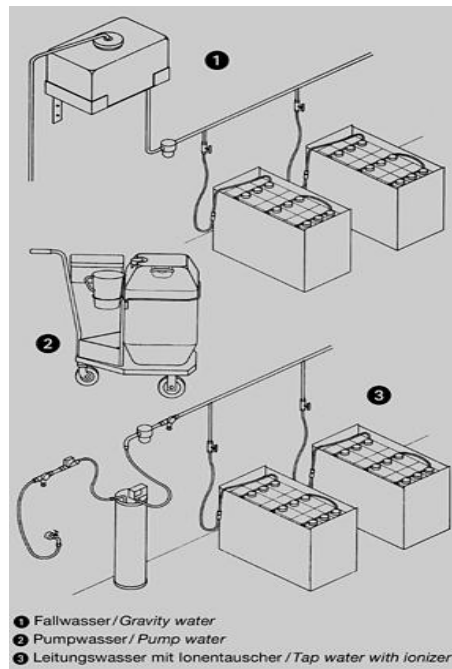

Battery spec.	Watering head	T-piece (6-10-6)	Flow indicator (filter)	6mm Watering pipe	10mm Watering pipe	end plug	Male/female K10	Water tank specification
	T-piece							
24 V	12 pcs	1 pcs	1 pcs	3m	5m	2pcs	1pcs	30L 1pcs
48 V	24 pcs	1 pcs	1 pcs	5m	5m	2pcs	1pcs	30L 1pcs
80 V	40 pcs	1 pcs	1 pcs	10m	5m	2pcs	1pcs	60L 1pcs

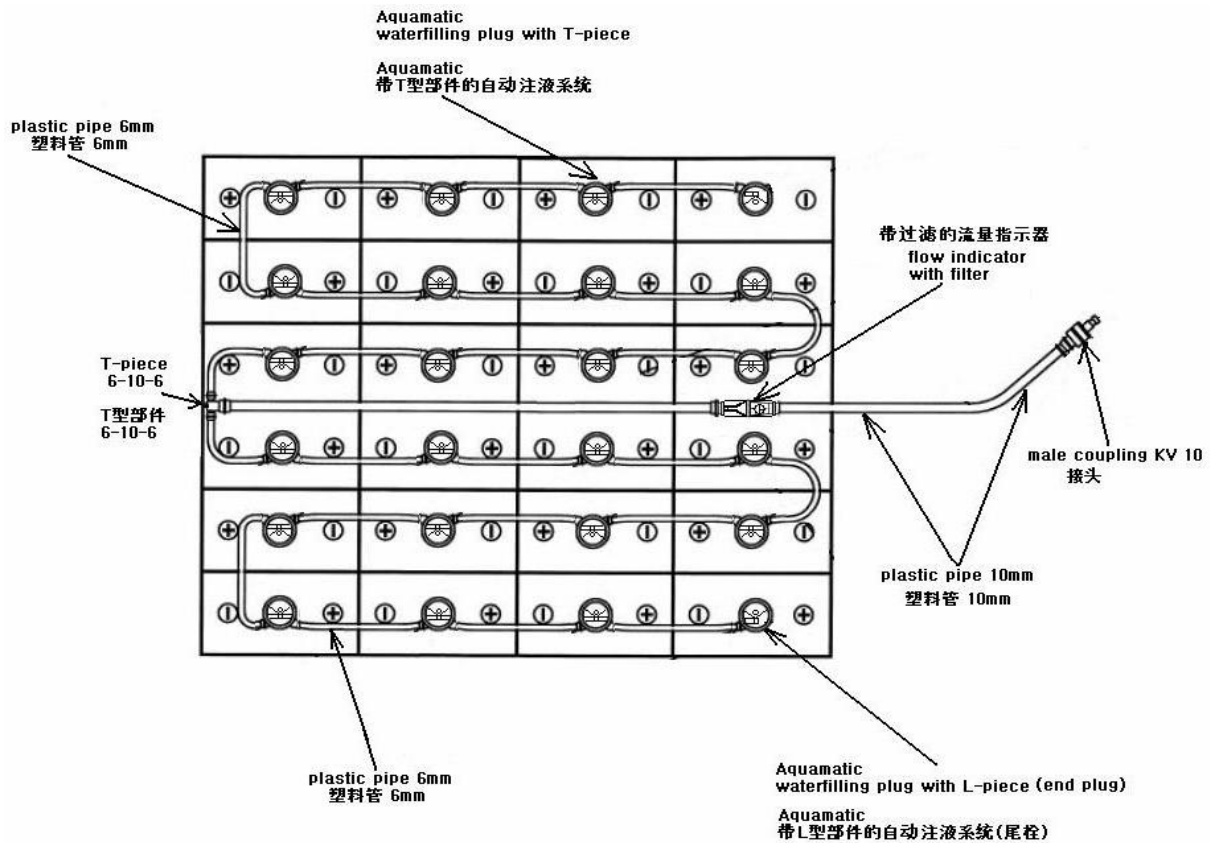

Automatic Watering System of Forklift Storage Battery-48V battery group

Floater

How to choose proper floaters correctly:

According to different storage battery, we have five kinds of floaters for you to choose. In order to achieve our expected standard and completely reflect the effectiveness of the automatic watering system, the most important thing is to choose proper floaters. At present our company can offer a rule for the client to make judgment and choose the type of floater. (see diagram)

The diagram the installation way of the floaters:

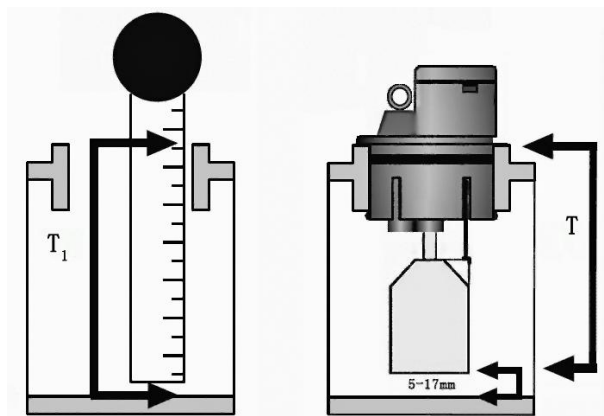

$T = T_1 - (5 \sim 17\text{mm})$

T approaching	47	50.5	58	61	72
Float	13	16.5	24	27	38

Watering pipe

Our company offers watering pipes of different types and the clients can choose what they need according to the specification of the battery. The watering pipe must be perfectly sealed with T-piece and L-piece.

Notes during the filling process:

- In order to ensure a safe watering process, we hereby recommend you to use flow indicator (with filter), the flow indicator with filter can not only timely indicate whether it finishes watering, but also avoid unclean impurities entering the battery to result interruption.
- You'd better conduct watering within the specified periods, because frequent filling will lead to overflowing for too much water, which will do great damage to the storage battery.

Note: Filling after finishing charging is the best ideal state, besides, do not filling before charging.

Cleaning

- During the period of development and long-term practical application, the leak tightness of automatic watering system has been completely approved.
- When you use it, you must pay much attention to keep the automatic watering system clean. No filth remaining on the surface.
- The users should regularly clean the watering plug for the plug is a kind of plastic good. Clean the surface directly with tap water and no need to use other detergent.

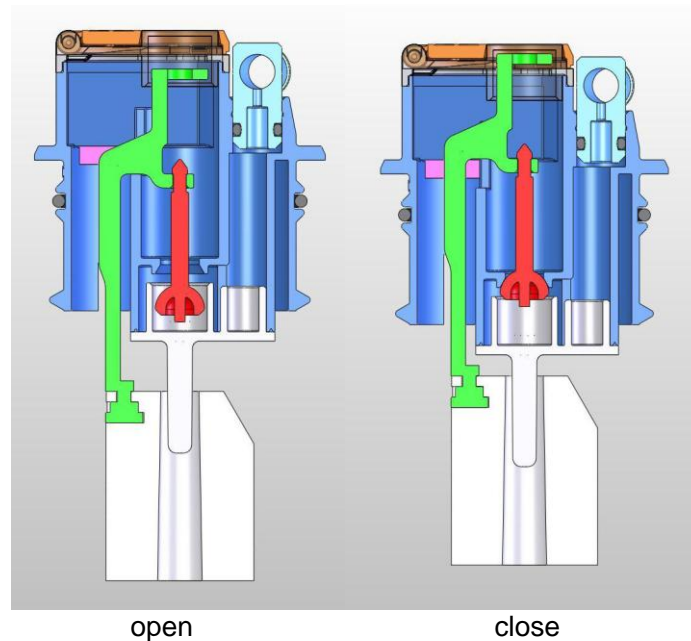

Structure Diagram of the Watering Plug

Characteristics of the automatic filling watering system

- No need to water by hand, labor saving.
- No malfunction factor leading to damage the battery.
- Easy & safe operation.
- Ensure a precise electrolyte level in every battery cell.
- Prevent leakage when watering.
- Effectively avoid the acid liquid to erode the storage battery and the electrolytic bath.
- Extend the service life of the battery.
- Environment protection.
- Save energy.

Function Introduction:

- Function of the automatic watering system: the floater of the automatic watering plug can reach correct water level, when the level rises in the cell, the pressure closes the valves and prevents further water entering the cell. When the system finishes watering, the flow indicator will stop running and you can see the water-level indicator clearly through the top of the watering system.
- Besides, the material of floater can avoid damage and ineffectiveness.
- As for the structure of automatic watering system, there is a terraced step, when the electrolyte gas rises to the watering plug, the terraced part can prevent the leakage of the electrolyte gas as well as quickly cool the electrolyte gas to make them go back to the storage battery in time.

17. Relevant safety command and standard (CE models)

The model with CE certification which accords to the following directive and standard: Machinery Directive 2006/42/EC (*The European Council of the Laws of the Member States concerning Machinery*), Noise Directive 2000/14/EC (*Directive of the Laws of the Member States concerning Outdoor Equipment Noise Radiation*), EN ISO 12100:2010 (*Safety of machinery — General principles for design — Risk assessment and risk reduction*), EN ISO 3691-1:2015+A1:2020, EN 16307-1:2020, EN 1175:2020, EN 12053:2001+A1:2008, EN 13059:2002+A1:2008, EN 60204-1:2018, etc. coordinative standards.

- Main safety factors accord with Machinery Directive 2006/42/EC, EN ISO 12100:2010, EN ISO 3691-1:2015+A1:2020, EN 1175:2020, EN 16307-1:2020, EN 60204-1:2018.
- Noise is measured according to EN 12053:2001+A1:2008.
- Vibration parameter is measured according to EN 13059:2002+A1:2008.

Model	A-weighted sound pressure level at the operator's position dB(A)	Whole-body vibration m/s ²
CPD40-XC4	74	0.9
CPD40-XC4-I	74	0.9
CPD45-XC4	74	0.9
CPD45-XC4-I	74	0.9
CPD50-XC4	75	1.0
CPD50-XC4-I	75	1.0
CPD50-XXC4	75	1.0
CPD50-XXC4-I	75	1.0

Model		Whole-body vibration m/s ²	At the operator' position: measure with sound pressure level dB(A)	Radiated noise power level dB(A)
CPD10-XD2	CPD10-XD2-I	0.70	65	87
CPD15-XD2	CPD15-XD2-I	0.70	65	87
CPD18-XD2	CPD18-XD2-I	0.70	66	87
CPD20-XD2	CPD20-XD2-I	0.70	66	87
CPD25-XD2	CPD25-XD2-I	0.72	66	87
CPD30-XD2	CPD30-XD2-I	0.72	66	87
CPD35-XD2	CPD35-XD2-I	0.73	67	88
CPD20-XXD2	CPD20-XXD2-I	0.75	68	88
CPD25-XLD2	CPD25-XLD2-I	0.75	68	88

- Electromagnetism compatibility is measured according to EN 12895:2015+A1:2019, and meet with 2014/30/EU Directive.
- Static test coefficient for lifting attachment is 1.33.

HANGCHA GROUP CO. , LTD.

- Address For: OVERSEAS USERS
- Address: 666 Xiangfu Road, Hangzhou, Zhejiang, China
- Fax: 0086-571-88926789 0086-571-88132890 ■ ZIP:311305
- Web: <http://www.hcforlift.com> ■ E-mail: sales@hcforlift.com