

P 140 T *Smart*

PALFINGER

LIFETIME EXCELLENCE

**FAST AND SECURE OPERATION FOR ALL
MAINTENANCE TASKS AT HEIGHT –
WITHOUT DRAWBACKS**



P 140 T *Smart*

WORKING DIAGRAMS

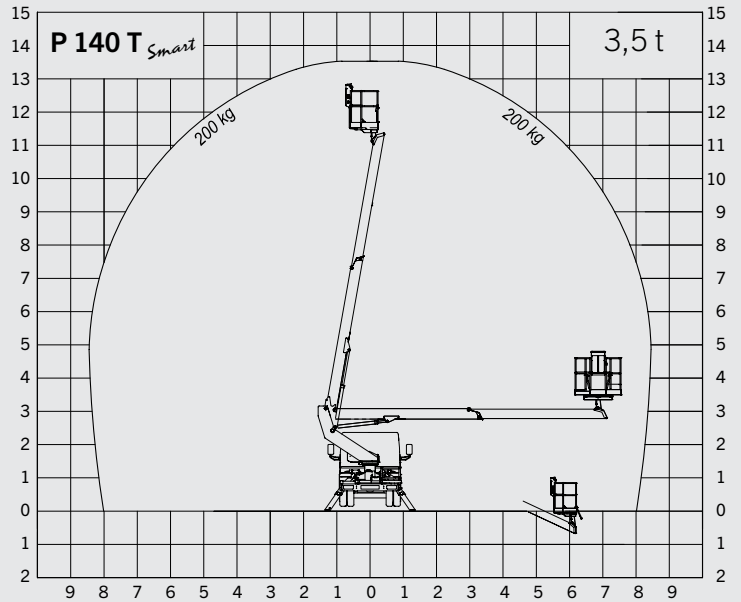
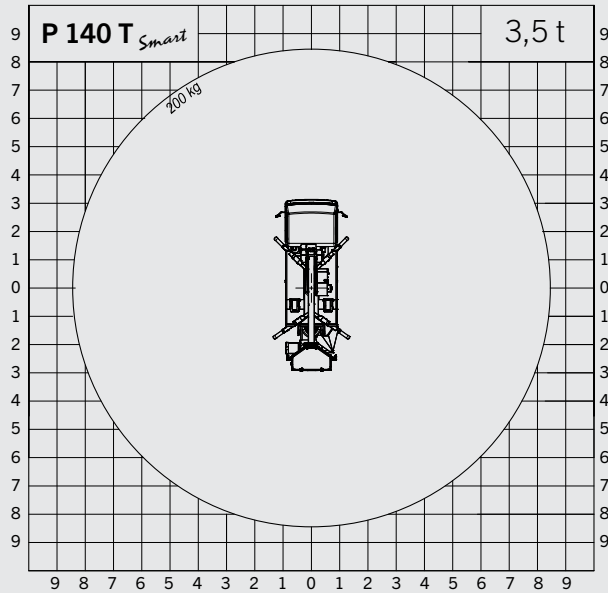

DIMENSIONS

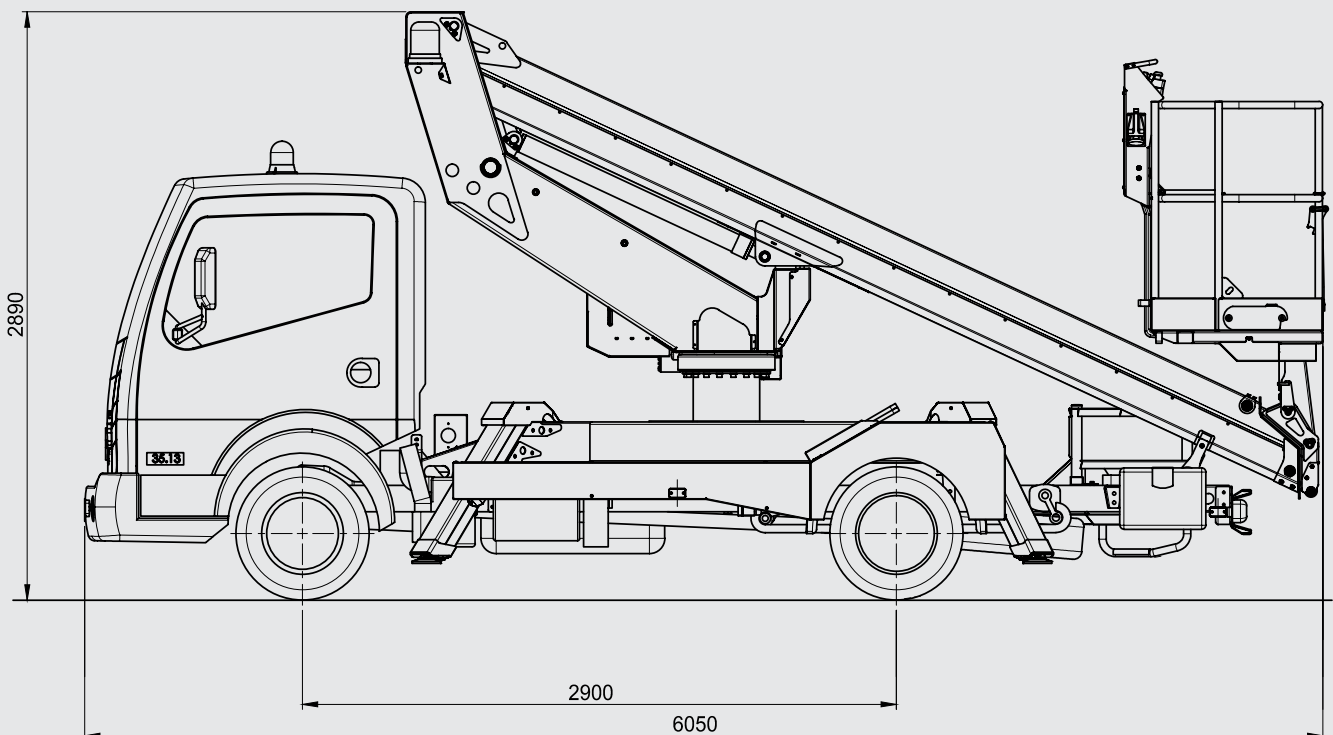



- Small & clever for use in city centres
- Compact design and easy operation
- Fully hydraulic operation
- Ergonomic design
- High manoeuvrability thanks to the extremely short wheelbase
- Safe working
- Professional PALFINGER quality

TECHNICAL SPECIFICATIONS

Max. working height	13.5 m
Max. basket bottom height	11.5 m
Max. outreach	8.4 m
Angle of main boom	-25° to + 80°
Rotation angle of turntable	370°
Rotation angle of basket	2 x 90°
Basket load	stand. 200 kg
Size of basket	1.4 x 0.85 x 1.1 m
Height in transport position	2.89 m
Width in transport position	2.1 m
Total length	6.05 m
Total weight	3200 kg

OPTIONAL

Fiberglass basket
Basket capacity 230 kg
Insulation 1000 V
Aluminium Side bars 200 mm
Basket load device
Electric motor 230 V
Working adjustable light 60 W on the basket
Customised paintwork boom

LIFETIME EXCELLENCE

THE RESULT IS **PALFINGER ACCESS PLATFORMS** FEATURING THE MOST STATE-OF-THE-ART HEIGHT TECHNOLOGY THAT ACHIEVE ABSOLUTE PEAK PERFORMANCES, EVEN WHEN CONFRONTED WITH THE MOST DIFFICULT OF JOBS IN PRACTICE. **DEVELOPED FOR THE GLOBAL MARKET, DESIGNED FOR THE FUTURE.**

BETTER
SOLUTIONS

BETTER
EFFICIENCY

BETTER
ERGONOMICS

HIGHER VALUE
RETENTION

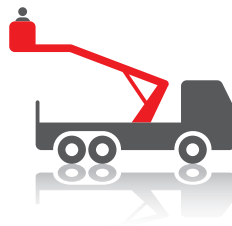

HIGHER
AVAILABILITY

HIGHER
SERVICEABILITY

BETTER
ECOLOGY

MORE
RELIABILITY

For further information please visit: www.palfinger.com/thebrand