

Performance

Lifting height — on stabilisers	17466.0 mm
Lifting height — on tyres	16200.0 mm
Rated capacity	4000 kg
Capacity (at max. height on stabilisers)	2500 kg
Capacity (at max. height on tyres)	1000 kg
Capacity (at max. reach on stabilisers)	500 kg
Max. reach on tyres	12800.0 mm

Weights

Weight (unladen)	10510 kg
------------------	----------

Traction

Standard tyres	DUNLOP 400/80-24 156B T37
1st gear / low range	4.8 km/h
1st gear / high range	24.0 km/h

Drive System

Transmission	Hydrostatic with electronic regulation
Main drive	Hydrostatic motor

Engine

Make / Model	Bobcat D34
Fuel	Diesel
Cooling	Coolant
Rated power (ISO 14396:2002) at 2400 RPM	75.0 HP
Rated power (ISO 14396:2002) at 2400 RPM	55.2 kW
Maximum torque at 1400 RPM	325.0 Nm
Number of cylinders	4
Displacement	3.40 L

Hydraulic System

Pump type	Gear pump with LS valve
Pump capacity	80.00 L/min
Relief valve pressure setting	250.00 bar

Cycle Times

Lift time - no load	15.8 s
Lower time - no load	9.9 s
Telescope in time at max. reach - no load	21.8 s
Telescope in time at max. height - no load	20.4 s
Telescope out time at max. reach - no load	36.5 s
Telescope out time at max. height - no load	36.5 s

Brakes

Engine braking	Hydrostatic
Parking and emergency brake	Passive brake

Fluid Capacities

Fuel tank	145.00 L
Hydraulic reservoir	76.00 L

Environmental

Operator noise level (LpA) (EN 12053)	74 dB(A)
Level of acoustic power (LWA)	104 dB(A)
Whole body vibration (EN 13059)	1.20 ms ⁻²

Load Charts

With forks and standard 400/80x24 tyres, on stabilisers

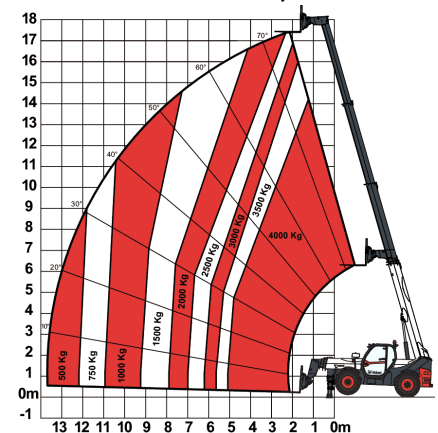
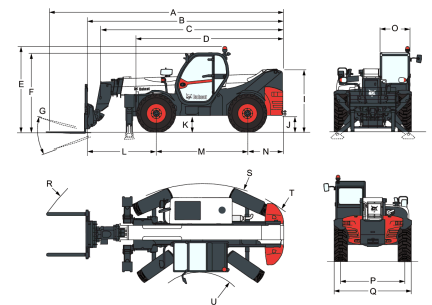
Dimensions

(-) 857.0 mm	(L) 2263.0 mm
(A) 7425.0 mm	(M) 2850.0 mm
(B) 6220.0 mm	(N) 1107.0 mm
(C) 5821.0 mm	(O) 930.0 mm
(D) 4573.0 mm	(P) 1992.0 mm
(E) 2673.0 mm	(Q) 2418.0 mm
(F) 2536.0 mm	(R) 5840.0 mm
(G) 124.0°	(S) 4150.0 mm
(I) 1956.0 mm	(U) 1519.0 mm
(J) 509.0 mm	