

SINGLE - THE SINGLE-DISC SANDING MACHINE



English / Englisch

# Operation, Maintenance, Safety

Translation of the original operating instructions  
for the single-disc sanding machine

## SINGLE

**Lägler**®

00.850.20.002 01.02.2013



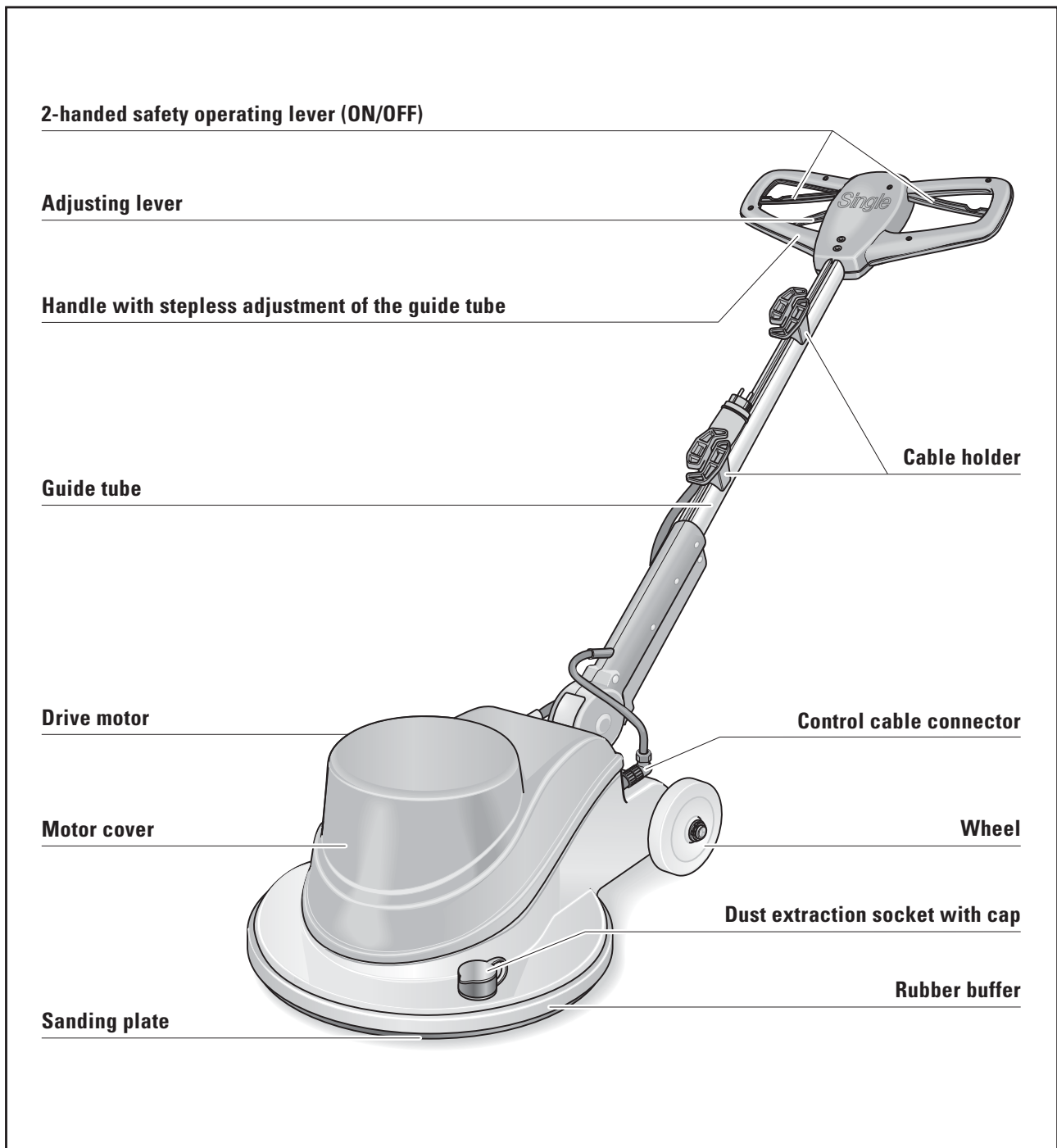

Fig. 1 Assemblies of the SINGLE single-disc sanding machine

---

## CONTENTS

---

|     |  |    |
|-----|--|----|
| 1   | Introduction.....  | 4  |
| 1.1 | Features of the machine .....  | 4  |
| 1.2 | Description of the machine .....   | 4  |
| 1.3 | Intended use of the machine.....   | 4  |
| 1.4 | Danger warnings .....  | 5  |
| 1.5 | Safety devices.....  | 6  |
| 2   | Technical data.....  | 6  |
| 3   | Getting started .....  | 8  |
| 3.1 | Preparing the machine for operation .....  | 8  |
| 3.2 | Connecting the mains cable .....   | 9  |
| 3.3 | Starting the machine.....  | 9  |
| 3.4 | Switching off the machine.....   | 10 |
| 4   | Working with the SINGLE .....  | 11 |
| 4.1 | General application tips.....  | 11 |
| 4.2 | Changing the sanding plate.....  | 11 |
| 4.3 | Changing the sanding disc .....  | 12 |
| 4.4 | Adjusting and replacing the cable holder.....  | 14 |
| 4.5 | Attaching an external vacuum cleaner.....  | 14 |
| 4.6 | Attaching the fluffy sealing strip as protection against dust.....                       | 15 |
| 5   | Transport and storage.....   | 16 |
| 5.1 | Dismantling and assembling the machine .....   | 16 |
| 5.2 | Storage .....  | 16 |
| 6   | Maintenance and replacement of wearing parts .....                                       | 17 |
| 6.1 | Cleaning and care instructions .....   | 17 |
| 6.2 | Replacing the plate mounting and the shock absorber.....                                 | 17 |
| 6.3 | Replacing the wheels.....  | 19 |
| 6.4 | Replacing the centering dome on the sanding plate.....                                   | 19 |
| 7   | Regular maintenance and testing in accordance with accident prevention regulations ..... | 20 |
| 8   | Troubleshooting .....  | 21 |
| 9   | General safety remarks.....  | 22 |
| 10  | Circuit diagrams.....  | 26 |
| 11  | Spare parts.....   | 28 |
| 12  | Service passport.....  | 39 |
| 13  | EU Declaration of conformity .....   | 40 |

# Introduction

You are now the owner of a high-quality product manufactured by LÄGLER®. We wish you every success with the SINGLE. This machine has been manufactured using state-of-the-art production techniques. All LÄGLER® products are subjected to thorough controls before they leave the factory.

Please read right through these operating instructions before working with the SINGLE for the first time. The operating instructions contain important information relating to working safety and will answer many of your questions, permitting you to work confidently and safely with the machine. If you require information which is not provided in these instructions, refer to your sanding instructions or consult our Customer Services Department, which will be pleased to advise you. Our fully trained and qualified service technicians are very familiar with the SINGLE and will be able to provide any assistance you may need.

## 1.1 FEATURES OF THE MACHINE

Fig. 1 (page 2) shows the most important assemblies which make up the SINGLE. We recommend that you take some time to become familiar with the machine.

## 1.2 DESCRIPTION OF THE MACHINE

The SINGLE single-disc sanding machine operates with a sanding plate to which Velcro-backed sanding discs can be attached. Of course, the traditional type of sanding disc with a fastening screw can also be used on the machine. The work zone is covered by the machine housing. In the machine housing, the electric motor is mounted vertically together with the gear. It is protected from sanding dust by the motor cover. The plug for connection to the mains is located on the machine housing. The motor switch with the switch positions ON/OFF is located in the handle at the top end of the guide tube. The machine is moved with this handle. At the back of the machine are two wheels which the machine runs on when it is moved.

**The SINGLE single-disc sanding machine is intended for dry use only. Never attempt to use the SINGLE for any type of wet operation (risk of fatal accidents)!**

## 1.3 INTENDED USE OF THE MACHINE

The SINGLE single-disc sanding machine is suitable for sanding wooden and cork floors and for work on floor underlays in the professional and DIY rental sectors. It can also be used for spreading care products and cleaning agents and for polishing floors.

**Any application other than that described here is inadmissible without the consent of the manufacturer. Never use for wet operation!**

## 1.4 DANGER WARNINGS

Please read through the danger warnings carefully and instruct your employees or colleagues accordingly. Failure to comply with this requirement could result in dangerous situations or injury.

**In order to avoid injury, the machine may only be switched on when it is in the working position, the sanding plate is placed flat on the floor and the dust extraction socket is closed (please see *Section 3.3, Starting the machine*).**

Use only tools, accessories and spares intended for the SINGLE and supplied by LÄGLER®. No warranty cover exists for parts sourced from other manufacturers. Use of other parts can result in damage to the machine, to the floor you are sanding, or injury to the machine operator.

Incorrect transportation can result in damage to the equipment.

**Keep well away from sources of fire.**

**Do not smoke when there is dust in the atmosphere (e.g. while working with the machine or emptying out the dust)**

**→ This could cause a dust explosion.**

The mains connection cable must be kept out of the work area in order to prevent mechanical or electrical damage.

In order to prevent any chance of the machine being unintentionally started up, the power supply must be cut off when the machine is switched off, by unplugging from the mains.

To protect the equipment against current faults, we advise using a DI safety plug (For part nos. please see *Section 11, Spare parts*).

When the appliance is operated correctly with a vacuum cleaner (please see *Section 4.5, Attaching an external vacuum cleaner*), the prescribed dust limit values are adhered to. When the appliance is used without a vacuum cleaner connected, a respiratory protection mask P3 must be worn (For part nos. please see *Section 11, Spare parts*).

**Never use the sanding machine for any type of wet operation!**

**When the machine is switched on, there is still a serious residual risk involved, despite all the safety devices fitted. For this reason, never reach into rotating tools or machine parts!**

## 1.5 SAFETY DEVICES

The following parts of the machine are safety devices and must accordingly be kept in perfect working order:

|                                 |  |
|---------------------------------|--|
| Machine housing                 | = Protection from sanding plate and sanding disc |
| Dust extraction socket with cap | = Protection from sanding plate and sanding disc |
| Motor cover                     | = Protection from live parts                     |
| Handles on the guide tube       | = Protection from live parts                     |

# Technical data

**Note on noise emission:**

The specified values are emission values and are not required to constitute safe workplace levels. Although a correlation does exist between emission and imission levels, it is not possible to conclude on this basis whether additional precautionary measures are necessary. Factors which influence the current imission level existing at the workplace include the duration of exposure, the character of the workroom, other noise sources such as the number of machines, and other adjacent machining processes. The admissible workplace values can also vary from one country to another. However, this information is provided in order to enable the user to better estimate the level of danger and risk.

|   |   |
|---|---|
| Manufacturer.....   | Eugen Lägler GmbH   |
| Machine type.....   | Single-disc sanding machine   |
| Serial number .....   | see rating plate  |
| Year of construction.....   | see rating plate  |
| Motor type.....   | single-phase AC motor   |
| Voltage .....   | 230 V   |
| Frequency .....   | 50 Hz (CPS)   |
| Output.....   | 1.2 kW  |
| Fusing .....  | 16 A  |
| Insulation class .....  | B   |
| Protection rating .....   | IP 54   |
| Safety devices .....  | no-voltage release<br>thermal switch as overload<br>protection in the motor |
| Starting capacitor .....  | 60 µF   |
| Operating capacitor .....   | 40 µF   |
| Sanding plate diameter .....  | 406 mm (16")  |
| Sanding plate speed .....   | approx. 180 1/min (rpm)   |
| Total height without guide tube .....   | 265 mm (10 ½")  |
| Total length without guide tube .....   | 615 mm (24 ¼")  |
| Height above sanding plate .....  | 46 mm (1 ¾")  |
| Total width.....  | 435 mm (17 1/8")  |
| Weight of the machine with sanding plate.....   | 45 kg (99 lbs.)   |
| Workplace-related noise emission values<br>(Measuring point at the operator's ear; 1.5 m above floor level)<br>parquet sanding operation, sanding oak parquet |   |
| Sanding paper grain size 60.....  | 77 dB(A)  |
| Vibration total value $a_{hv}$ .....  | < 2.5 m/s <sup>2</sup><br>(measured at the handle)                          |

**Intended applications**

Sanding wooden and cork floors, work on floor underlays and spreading care products and cleaning agents.

**Basic equipment**

Machine ready for operation, extension cable 3 x 2.5 sq. mm - 10 m long, hexagonal socket wrench sizes 5 and 6, respiratory protection mask (P3) and operating manual.

**Optional equipment**

Universal sanding plate, vacuum cleaner (FESTOOL mobile extractor CTM44E230V), pocket for ear plugs, DI safety plug.

**Wearing parts**

To ensure that the machine works safely and to maximum effect, please check the condition of the wearing parts listed below at regular intervals:

- Replace Velcro attachment disc on the sanding plate if worn or damaged
- Replace paper retaining disc if worn or damaged
- Replace screw for attaching paper disc if worn or damaged
- Replace wheels if worn or damaged
- Replace extension cable if damaged
- Replace motor cable if damaged
- Replace buffer if damaged
- Replace fluffy sealing strip if damaged

**Note:**

The motor data mentioned above relates to machines used in the Federal Republic of Germany. Different data may apply to exported machines. This is indicated on the motor rating plate.

The relevant article numbers of the optional accessories and wearing parts are provided in the spare parts lists *in Section 11*.

# Getting started

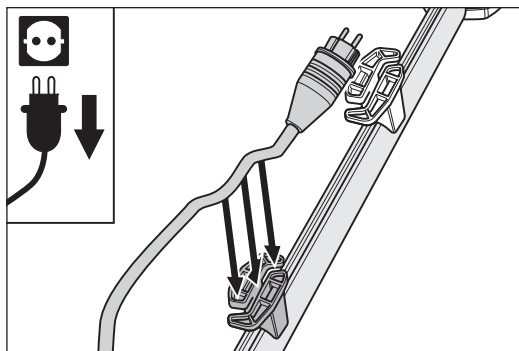

Fig. 2 Insert the motor cable in the lower cable holder on the guide tube.

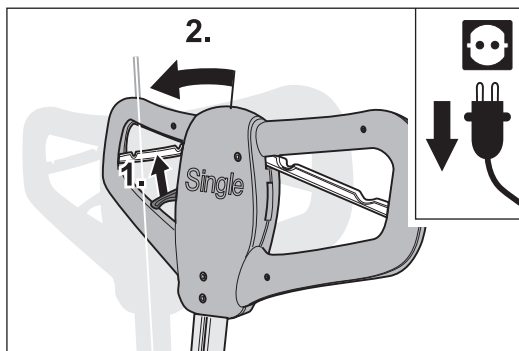

Fig. 3 Pull the adjusting lever to release the lock and raise the guide tube until it reaches the mechanical stop.

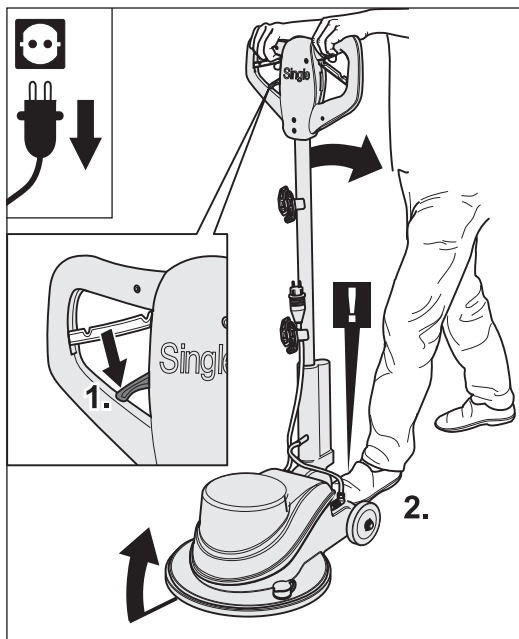

Fig. 4 Release the adjusting lever and carefully tilt the machine backwards. Steady the machine with your foot to stop it rolling away and ensure that it is stable!

This section describes the procedure for commissioning the SINGLE on site. In order to exclude the possibility of damage and malfunctions, it is essential to proceed in the sequence outlined below.

**Before working with the machine for the first time, operating staff must be adequately instructed.**

## 3.1 PREPARING THE MACHINE FOR OPERATION

**1** Unpack the machine carefully. Please ensure that packaging materials that are no longer needed are disposed of responsibly, in an environmentally-friendly way.

**For safe dispatch of the machine at a subsequent date, the original packaging should be retained and used again.**

**2** Attach the sanding disc you need to the sanding plate (*Section 4.3, Changing the sanding disc*).

**3** Insert the motor cable in the lower cable holder on the guide tube (Fig. 2).

**4** Pull the adjusting lever on the handle towards you to release the lock of the guide tube, and push the guide tube into and past the vertical position until it reaches the mechanical stop (Fig. 3).

**5** Release the adjusting lever so that the guide tube can engage again. Carefully tilt the machine backwards on the wheels. As you do so, steady the machine with your foot to stop it rolling away (Fig. 4). **Please ensure that the machine is stable before commencing work!**

**6** Push the sanding plate centrally onto the gear mount and turn it anti-clockwise until it reaches the mechanical stop (Fig. 5).

**7** Carefully tilt the machine back up over the wheels and onto the sanding plate. As you do so, steady the machine with your foot to stop it rolling away (Fig. 6).



- 8 The height of the guide tube can be adjusted, allowing you to work with the SINGLE as comfortably as possible. To make this adjustment, pull the adjusting lever towards you (Fig. 3). This releases the lock on the guide tube so that it can be moved up or down. Choose the position that feels most comfortable to you (Fig. 7) and release the adjusting lever again.

**NOTE:**

**This adjustment must never be made when the machine is switched on!**

### 3.2 CONNECTING THE MAINS CABLE

- 1 Push the socket onto the plug on the motor cable and insert the extension cable in the upper cable holder on the guide tube (Fig. 8).
- 2 Plug the extension cable plug into an adequately fused mains socket with protective contacts or into the socket of a separate vacuum cleaner (please see also *Section 4.5, Attaching an external vacuum cleaner*).

### 3.3 STARTING THE MACHINE

**NOTE:**

**Please read this section very carefully. It contains important safety instructions!**

**NEVER switch the machine unless:**

- There is a sanding plate mounted (Fig. 9).
- The machine is in the working position and the sanding plate is placed flat on the floor (Fig. 10).
- The dust extraction socket is closed either with its cap or a vacuum cleaner hose (Fig. 12, please see also *Section 4.5, Attaching an external vacuum cleaner*).

If these conditions are not met, the sanding plate can come free of its mount and parts or fingers can catch on the rotating sanding plate, resulting in damage or injury!

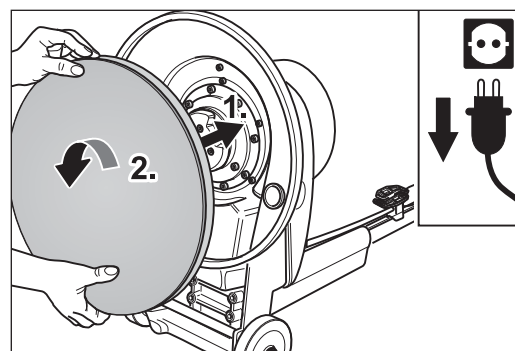

Fig. 5 Push on the sanding plate and turn it anti-clockwise until it reaches the mechanical stop.

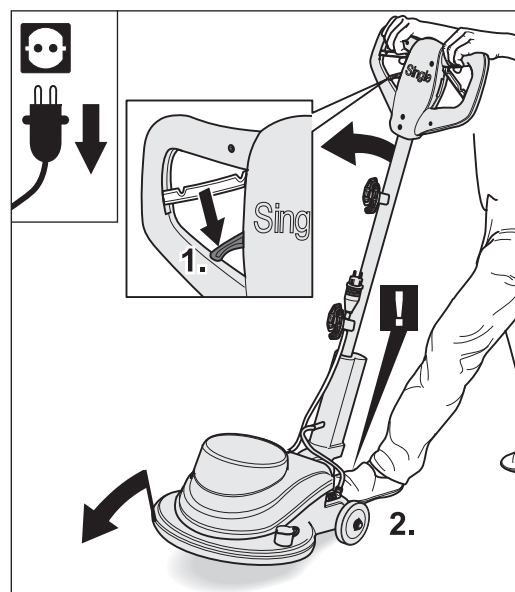

Fig. 6 Tilt the machine back up, holding it steady with your foot to stop it rolling away.

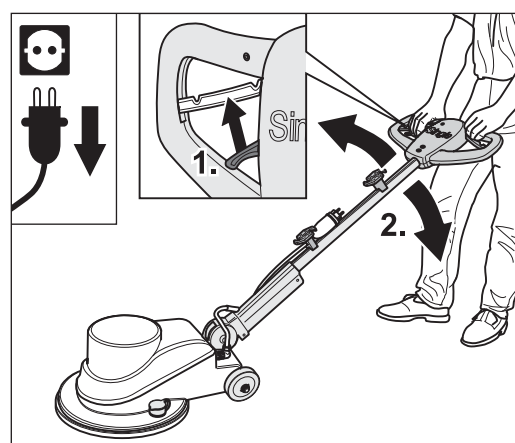

Fig. 7 Set the handle to a position that feels comfortable to you.

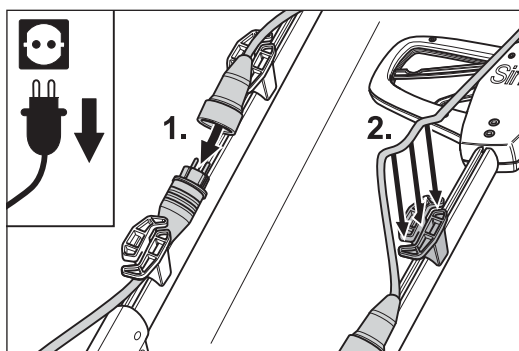

Fig. 8 Insert the extension cable in the upper cable holder on the guide tube.

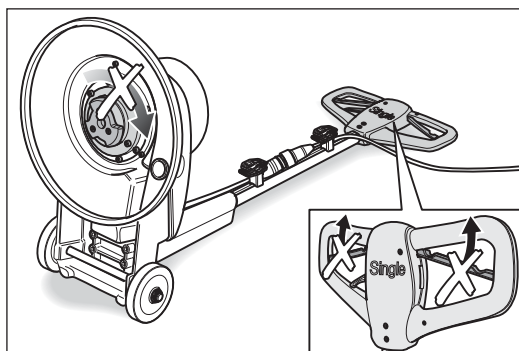

Fig. 9 Never switch on the machine unless there is a sanding plate mounted!

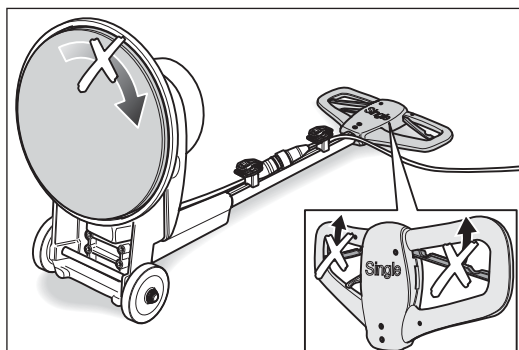

Fig. 10 Never switch on the machine unless it is in the working position and the sanding plate is placed flat on the floor!

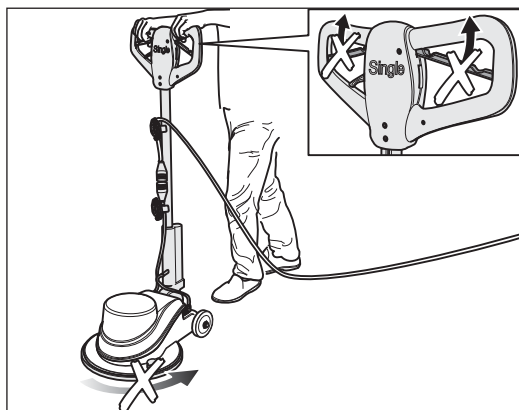

Fig. 11 If the guide tube is in a vertical position, the machine CANNOT be switched on!

For safety reasons, the machine CANNOT be switched on:

- If the guide tube is in a VERTICAL POSITION, since this makes the machine very difficult to control (Fig. 11).
- UNLESS both start levers on the handle are pulled AT THE SAME TIME. Holding the machine steady with both hands enables you to control the machine properly when it is switched on, despite the motor starting torque.

**Professional tip:**

**To start up the machine with almost no jerking movement, we recommend lifting the machine VERY SLIGHTLY at the handle immediately after you switch it on.**

Before switching on the machine, ensure that:

- the sanding plate is placed flat on the floor and
- the guide tube is not in a vertical position and
- the dust extraction socket is closed either with its cap or with a vacuum cleaner hose!

**When you have made these checks, the SINGLE can be started!**

Pull both the start levers AT THE SAME TIME and hold the handle tight with both hands (Fig. 12). The machine will start up.

**Never allow the machine to run unattended, otherwise damage or injury can occur!**

**Always pull the mains plug out of the socket once you have finished working.**

### 3.4 SWITCHING OFF THE MACHINE

To switch off the machine, release both the start levers but keep a tight hold on the machine with both hands on the handle, until the sanding plate has come to a complete standstill.

Never allow the machine to run unattended and always pull the mains plug out of the socket once you have finished working.

# Working with the SINGLE

## 4.1 GENERAL APPLICATION TIPS

It is possible to avoid leaving deep sanding tracks caused by excessively coarse abrasion grain size by initially selecting a fine grain size for the first sanding process.

Carry out a test sanding process using a 50 or 60 grain size. If this test is satisfactory and you envisage a good sanding result within a reasonable period, it is more efficient to start the sanding work off with these finer grain sizes. This is the best way to avoid leaving deep sanding tracks caused by an excessively coarse grain size.

You can avoid creating sanding tracks from the previous grain size used by adhering to the grain size sequence and not skipping more than one grain size at a time.

After each sanding pass, vacuum the floor thoroughly. Keep the machine's wheels clean.

When changing to a new sanding disc, always start work in a less well lit area of the room until the sanding disc loses its initial aggressive sanding effect.

For other informative and important application tips, please refer to the LÄGLER® application technology brochure „Sanding wooden floors“!

## 4.2 CHANGING THE SANDING PLATE

- 1 Switch off the machine.
- 2 **Pull the mains plug out of the socket.**
- 3 Pull the adjusting lever on the handle towards you to release the lock of the guide tube, and push the guide tube into and past the vertical position until it reaches the mechanical stop (Fig. 13).

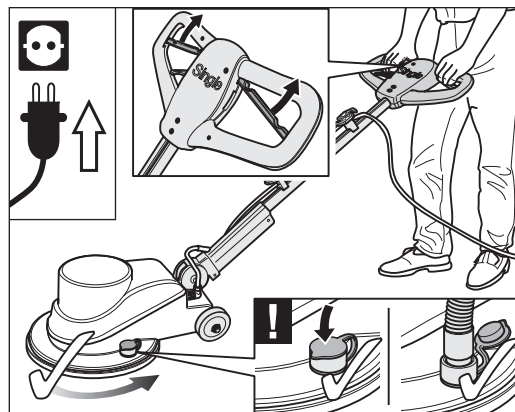

Fig. 12 Do not start the machine in this position unless  
- the sanding plate is placed flat on the floor AND  
- the dust extraction socket is closed either with its cap or a vacuum cleaner hose!  
Then pull both the start levers AT THE SAME TIME.

For more information free of charge, please apply to:

within Germany

- Tel.: 0800 / 52 34 537

- Fax: 0800 / 48 66 353

within the USA

- Tel.: 800-848-6635

or

- Tel.: 0049 - 7135 - 98 90-0

- Fax: 0049 - 7135 - 98 90-98

- e-mail: info@laegler.com

- Internet: http://www.laegler.com

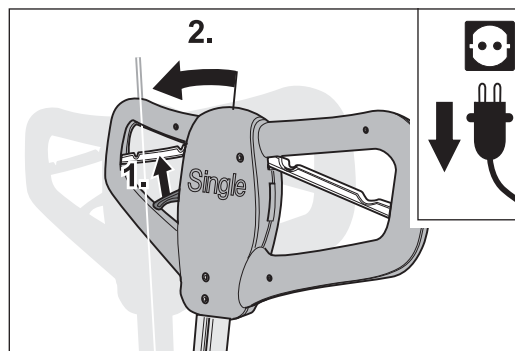

Fig. 13 Pull the adjusting lever to release the lock and push the guide tube up until it reaches the mechanical stop.

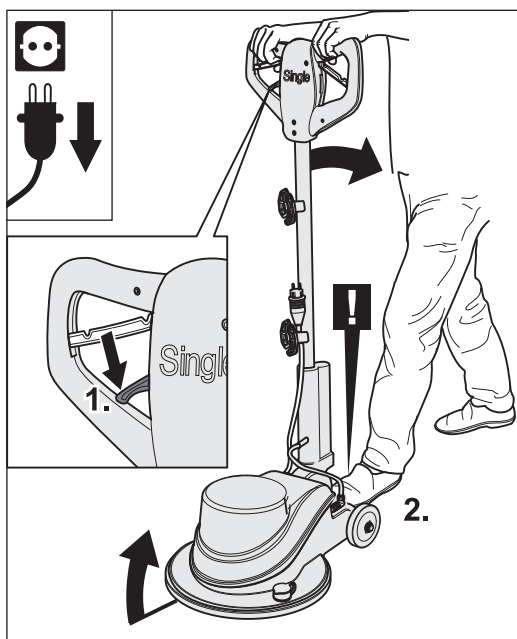

Fig. 14 Release the adjusting lever and carefully tilt the machine backwards. Ensure that the machine is stable!

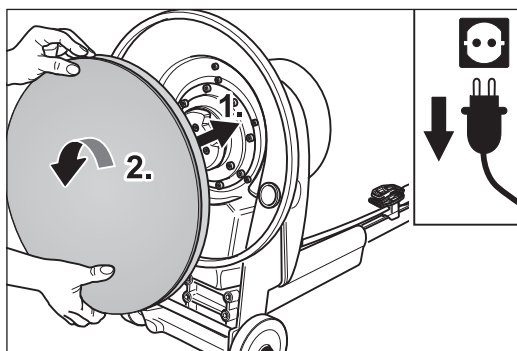

Fig. 15 Push on the sanding plate and turn it anti-clockwise until it reaches the mechanical stop.



Fig. 16 Release the adjusting lever and carefully tilt the machine back up.

- 4 Release the adjusting lever so that the guide tube can engage again. Carefully tilt the machine backwards on the wheels. As you do so, steady the machine with your foot to stop it rolling away (Fig. 14). **Please ensure that the machine is stable before commencing work!**
- 5 Turn the sanding plate clockwise and you can then remove it from the machine.
- 6 Push the other sanding plate centrally onto the gear mount and turn it anti-clockwise until it reaches the mechanical stop (Fig. 15).
- 7 Carefully tilt the machine back up over the wheels and onto the sanding plate. As you do so, steady the machine with your foot to stop it rolling away (Fig. 16).

#### 4.3 CHANGING THE SANDING DISC

Depending on the type of sanding process you wish to perform, different abrasive grain sizes can be selected. In order to change the abrasive, proceed as follows:

- 1 Switch off the machine.
  - 2 **Pull the mains plug out of the socket.**
  - 3 Pull the adjusting lever on the handle towards you to release the lock of the guide tube, and push the guide tube into and past the vertical position until it reaches the mechanical stop (Fig. 13).
  - 4 Release the adjusting lever so that the guide tube can engage again. Carefully tilt the machine backwards on the wheels. As you do so, steady the machine with your foot to stop it rolling away (Fig. 14). **Please ensure that the machine is stable before commencing work!**
- ##### 4.3.1 CHANGING VELCRO-BACKED SANDING DISCS
- 5 Pull the worn Velcro-backed sanding disc off the Velcro attachment disc of the sanding plate (Fig. 17).
  - 6 Press on the sanding disc with the Velcro side against the Velcro attachment ring of the sanding plate. As you do so, please ensure that the sanding disc is attached to the sanding plate as centrally as possible.

- 7 Carefully tilt the machine back up over the wheels and onto the sanding plate. As you do so, steady the machine with your foot to stop it rolling away (Fig. 16).

#### 4.3.2 CHANGING CONVENTIONAL SANDING DISCS

**NOTE:**

**So that sanding discs that are attached in the conventional way do not come loose during sanding work (because of the direction in which the plate rotates), the fastening screw for the paper retaining disc has a LEFT-HANDED THREAD.**

- 5 To release the paper retaining disc, turn the screw **clockwise** (LEFT-HANDED THREAD) with a hexagonal socket wrench. As you do so, hold the sanding plate steady (Fig. 18).
- 6 Unscrew and remove the fastening screw completely. Remove the paper retaining disc and the worn sanding disc from the sanding plate and lay them to one side.
- 7 Place a new sanding disc on the sanding plate and push the fastening screw with paper retaining disc into the sanding plate (Fig. 19).
- 8 Use the hexagonal socket wrench to turn the fastening screw **anti-clockwise** into the sanding plate (LEFT-HANDED THREAD)! Please ensure that the sanding disc is attached to the sanding plate as centrally as possible (Fig. 19).
- 9 Tighten the fastening screw as tightly as you can by hand, using the hexagonal socket wrench.

**Only ever attach one sanding disc, otherwise the sanding results will be unsatisfactory and the dust extraction system will not function properly!**

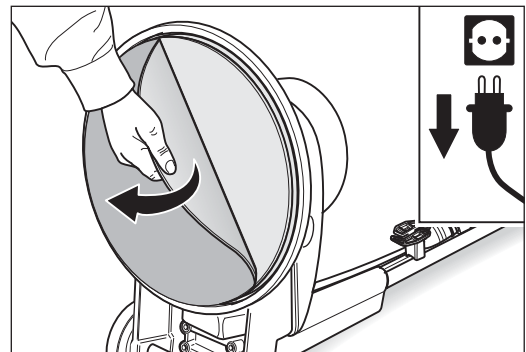

Fig. 17 Pull off the worn Velcro-backed sanding disc.

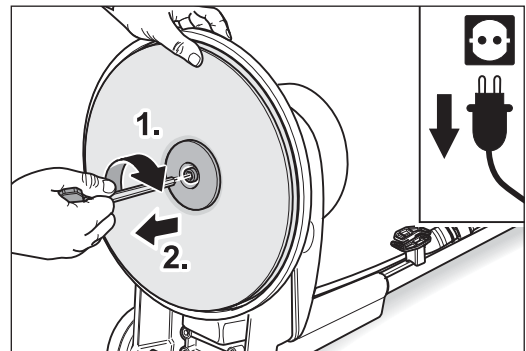

Fig. 18 Turn the screw for releasing the disc **in a clockwise** direction (it has a LEFT-HANDED THREAD)!

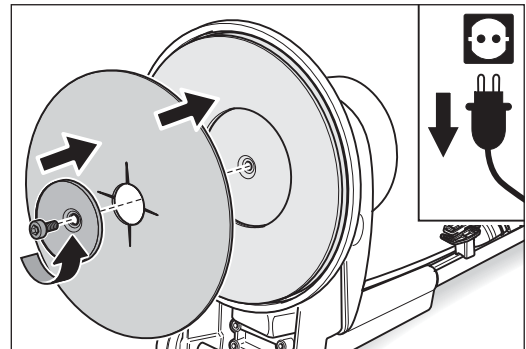

Fig. 19 Place the new sanding disc in the sanding plate and screw it in place. Turn the screw **anti-clockwise** to tighten (LEFT-HANDED THREAD)!

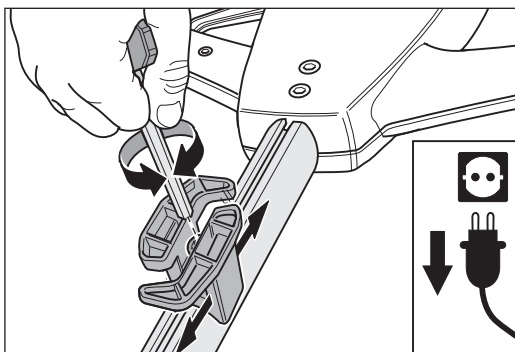

Fig. 20 Release the screw, move the cable holder with the sliding block and then tighten the screw again.

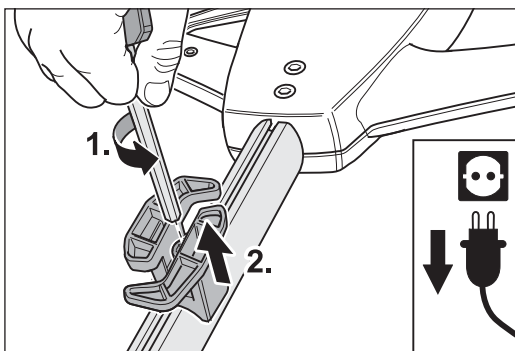

Fig. 21 Release the screw. Do NOT remove it completely, and remove the cable holder WITH the sliding block.

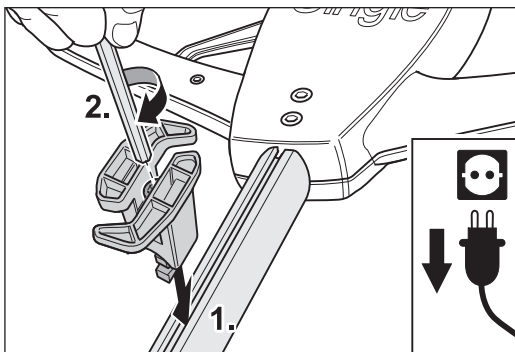

Fig. 22 Insert the sliding block in the groove on the guide tube and tighten the screw.

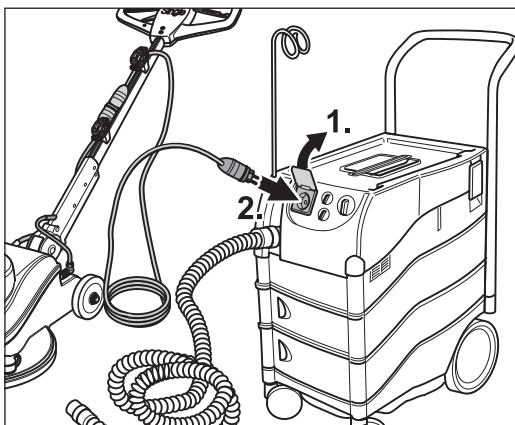

Fig. 23 Push the extension cable plug into the socket on the vacuum cleaner.

## 4.4 ADJUSTING AND REPLACING THE CABLE HOLDER

### 4.4.1 ADJUSTING THE CABLE HOLDER

The cable holder positions can be adjusted individually along the groove on the guide tube of the machine.

- 1 Using a hexagonal socket wrench, slacken the screw in the middle of the cable holder just enough to let you slide the cable holder along the groove with the sliding block (Fig. 20).
- 2 Slide the cable holder into the position you want it in and tighten the screw again. As you do so, the sliding block turns so that the cable holder is clamped in place (Fig. 20).

### 4.4.2 REPLACING THE CABLE HOLDER

- 1 To remove or replace a cable holder, slacken the screw in the middle of the cable holder. **Do not** remove the screw entirely from the sliding block! You can now remove the cable holder together with the sliding block (Fig. 21).
- 2 To mount a cable holder, push the screw with its washer into the hole on the cable holder and on the other side, screw the sliding block loosely onto the screw.
- 3 Push the sliding block into the groove on the guide tube and tighten the screw. As you do so, the sliding block turns so that the cable holder is clamped in place (Fig. 22).

## 4.5 ATTACHING AN EXTERNAL VACUUM CLEANER

We recommend attaching a FESTOOL mobile extractor CTM44E230V as an external vacuum cleaner. This guarantees that the best possible dust removal results are achieved. The description below applies only for vacuum cleaners of the type specified here.

### NOTE:

**Please comply with the safety specifications made by the vacuum cleaner manufacturer and read through the operating instructions for the vacuum cleaner carefully!**

- 1 Plug the mains plug of the SINGLE into the extension cable.
- 2 Plug the extension cable plug into the socket on the vacuum cleaner (Fig. 23).

- 3 Open the cap of the dust extraction socket on the machine housing and push the vacuum cleaner hose into the connection piece (Fig. 24).
- 4 Switch the vacuum cleaner to AUTO mode (Fig. 25). AUTO mode means that the vacuum cleaner switches on and off automatically when the SINGLE is switched on and off.

**Professional tip:**

**To make work easier, you can attach the extension cable to the suction hose of the vacuum cleaner with several cable binders. In this way you can ensure that the cable will not get caught up under the machine (Fig. 26). Use detachable cable binders for this purpose.**

- 5 When the machine is ready for use as described in the preceding sections, you can start with the first sanding pass.

#### 4.6 ATTACHING THE FLUFFY SEALING STRIP AS PROTECTION AGAINST DUST

A fluffy sealing strip around the circumference of the machine improves the dust extraction results by sealing off the gap between the working area of the machine and the floor.

You should attach the strip to the machine so that when the sanding plate is mounted, the strip is in contact with the floor right round the circumference of the machine (Fig. 27).

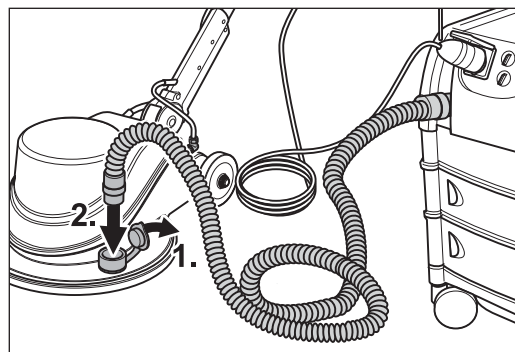

Fig. 24 Open the cap and attach the hose to the SINGLE.

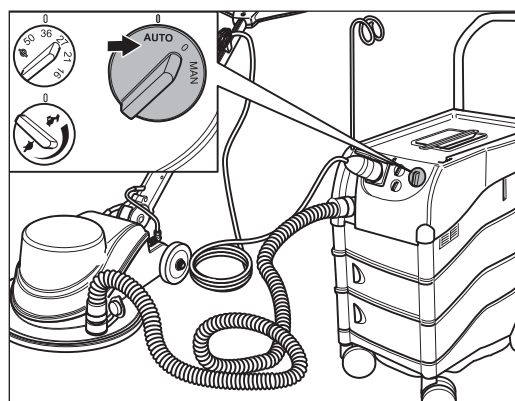

Fig. 25 Set the vacuum cleaner to the AUTO mode setting.

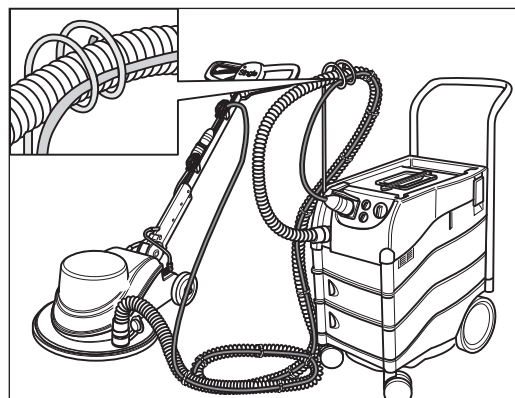

Fig. 26 Attach the extension cable to the vacuum cleaner suction hose.

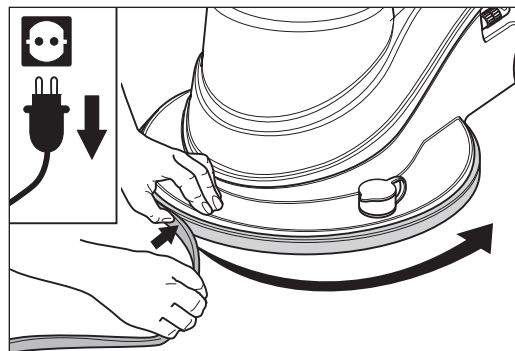

Fig. 27 Attach the fluffy sealing strip.

# Transport and storage

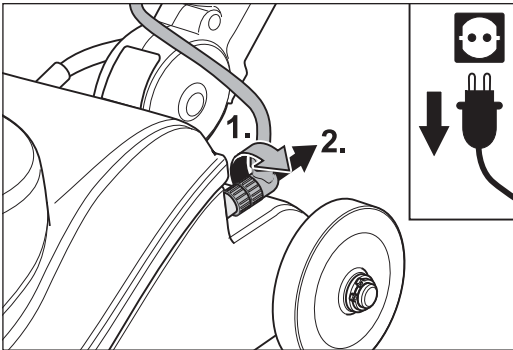

Fig. 28 Disconnect the cable plug of the guide tube from the machine housing.

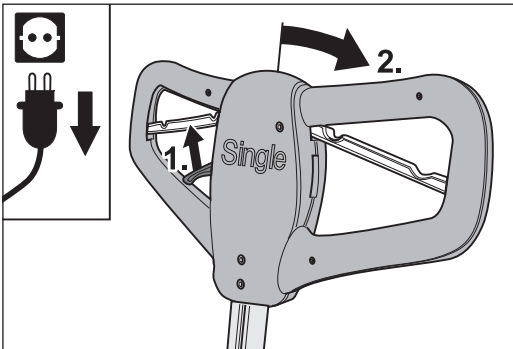

Fig. 29 Pull the adjusting lever to release the lock on the guide tube.

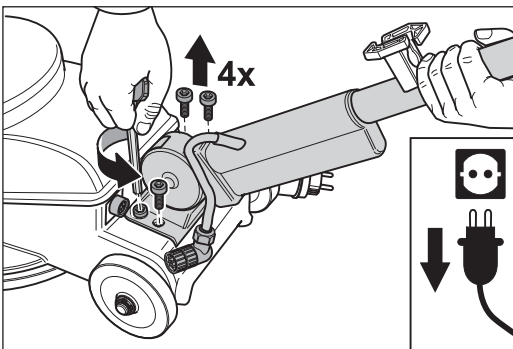

Fig. 30 Unscrew the guide tube.

### Professional tip

**When the machine is out of use for extended periods, you should remove the sanding plate from the machine, otherwise the weight of the machine can damage the flexible underlay of the sanding plate.**

**Also, when the machine is out of use for extended periods, you should place the machine on the bottom part of the transport packaging in which it is delivered.**

## 5.1 DISMANTLING AND ASSEMBLING THE MACHINE

For transportation, the machine can be dismantled into three parts: the guide tube as one element, the sanding plate and the drive unit (machine housing with motor). All parts must be adequately secured against slipping while being transported in the delivery van etc.

- 1 **Switch off the machine and pull the extension cable out of the socket.**
- 2 Take the motor cable and the extension cable out of the cable holder on the guide tube.
- 3 Remove the sanding plate (see *Section 4.2, Changing the sanding plate*).
- 4 Release the cable plug of the guide tube by turning the threaded ring on the cable plug and pull out the plug (Fig. 28).
- 5 Pull the adjusting lever on the handle towards you to release the lock of the guide tube (Fig. 29) and push the guide tube back into a horizontal position.
- 6 Use a hexagonal socket wrench to release the four fastening screws at the base of the guide tube. Steady the guide tube with one hand as you do so (Fig. 30).

To reassemble the machine, mount the individual components again in reverse order to that described above.

## 5.2 STORAGE

If you wish to keep the machine in storage for a protracted period, ensure that it is kept dry and free of the influence of frost in a location without excessive temperature fluctuations.



# Maintenance and replacement of wearing parts

Periodically, but at the latest when you notice that damage has occurred, a variety of maintenance procedures have to be performed. For this work, always use original spare parts manufactured by LÄGLER®. Work in a clean, well lit location and proceed in accordance with these instructions.

For safety reasons, more extensive maintenance work, especially on the electrical equipment, must be carried out by a qualified specialist.

## 6.1 CLEANING AND CARE INSTRUCTIONS

**Never use cleaning agents containing solvents.**

Before starting work, you should perform the following care procedure in order to ensure that the machine is in full working order and produces the customary high-quality sanding finish:

- Clean the machine's wheels.
- Clean all dust or other residues off the moving parts at the base of the guide tube.
- Carry out a visual inspection of the electrical equipment (extension cable, plug, couplings).

## 6.2 REPLACING THE PLATE MOUNTING AND THE SHOCK ABSORBER

Always use original LÄGLER® plate mountings and shock absorbers (For part nos. please see *Section 11, Spare parts*).

- 1 Switch off the machine and pull the extension cable out of the socket.**
- 2 Pull the adjusting lever on the handle towards you to release the lock of the guide tube, and push the guide tube into and past the vertical position until it reaches the mechanical stop (Fig. 31).**

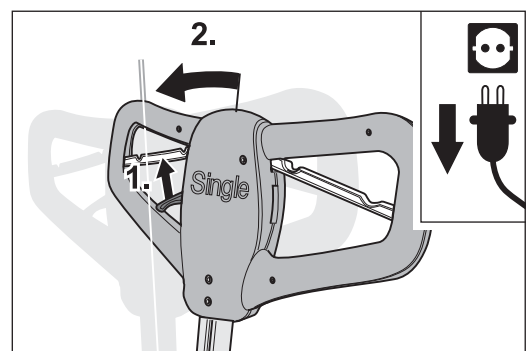

Fig. 31 Pull the adjusting lever to release the lock and push the guide tube up until it reaches the mechanical stop.

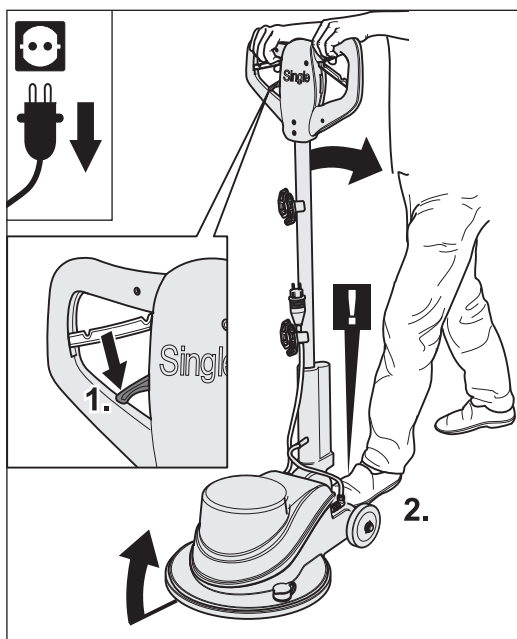

Fig. 32 Release the adjusting lever and carefully tilt the machine backwards. Ensure that the machine is stable!

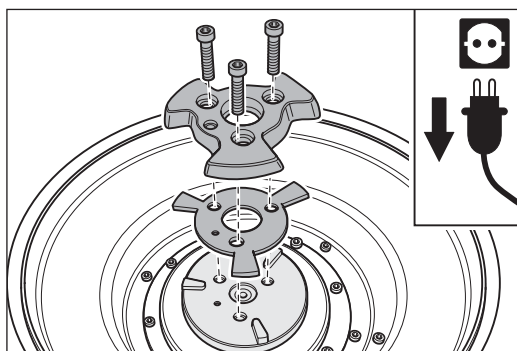

Fig. 33 Replace the plate mounting and the shock absorber.

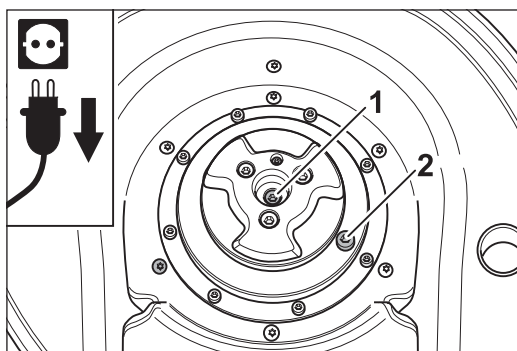

Fig. 34 The two screws with markings are oil drainage screws. **DO NOT UNSCREW THEM!**

- 3 Release the adjusting lever so that the guide tube can engage again. Carefully tilt the machine backwards on the wheels. As you do so, steady the machine with your foot to stop it rolling away (Fig. 32). **Please ensure that the machine is stable before commencing work!**
- 4 Release and remove the three screws that fasten the plate mounting in place.
- 5 Use two screwdrivers or something similar to lever the plate mounting off the retaining pin.
- 6 Remove the shock absorber (Fig. 33).
- 7 Replace the parts that are damaged or worn.
- 8 The gear of the SINGLE is maintenance-free and contains a special oil. The incorrect volume of oil can cause severe damage to the gear.  
**For this reason, NEVER open the oil drainage screws in the motor shaft or in the gear cover (Fig. 34).**
- 9 To assemble, follow the instructions above in reverse order. Please ensure that the pattern of holes on the shock absorber and the plate mounting match the pattern on the gear output.

### 6.3 REPLACING THE WHEELS

Always use original LÄGLER® wheels (For part nos. please see *Section 11, Spare parts*).

- 1 **Switch off the machine and pull the extension cable out of the socket.**
- 2 Use a suitable pair of circlip pliers to remove the retaining ring from the wheel axle. Remove the washer and the wheel (Fig. 35).
- 3 To mount the new wheel, follow the instructions above in reverse order.

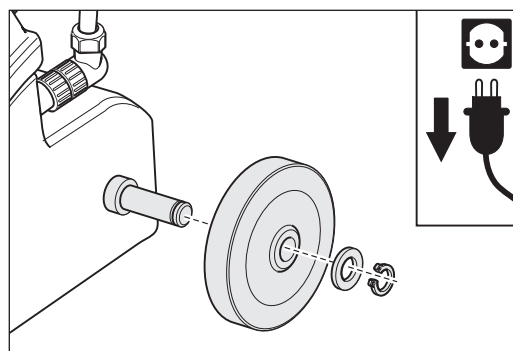

Fig. 35 Remove the retaining ring and remove the washer and the wheel. Install again in reverse order.

### 6.4 REPLACING THE CENTERING DOME ON THE SANDING PLATE

- 1 Remove the sanding plate from the SINGLE and lay it on the floor with the flat side down.
- 2 Turn the centering dome **clockwise** out of the sanding plate with an open-ended or ring spanner (LEFT-HANDED THREAD, Fig. 36)!
- 3 To mount the new centering dome, screw it **anti-clockwise** into the sanding plate (LEFT-HANDED THREAD)!

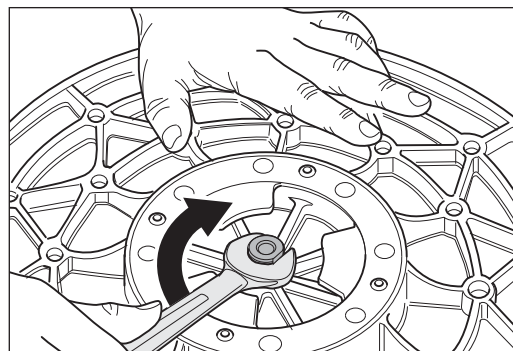

Fig. 36 To remove the centering dome, turn it **in a clockwise** direction (LEFT-HANDED THREAD)!

# Regular maintenance and testing in accordance with accident prevention regulations

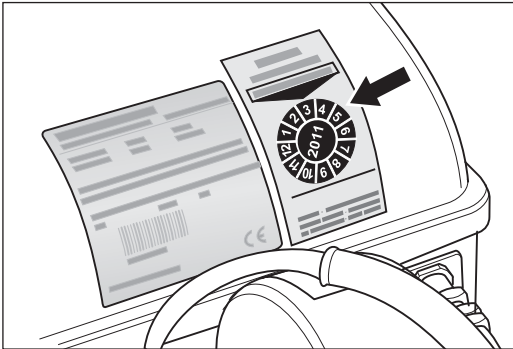

Fig. 37 The test seal is proof of safety certification.

The electrical operating equipment and machine components must be checked for their electrical and mechanical safety at least once a year by a specialist, repaired if necessary and then their safety certified by application of a test seal on the machine.

The elements required for dust pick-up must be checked at least once a year by a specialist and also repaired if necessary. They must also be certified as being in good working order.

Ensure that only original LÄGLER® spare parts are used for maintenance work. After-sales servicing should only be performed by LÄGLER® or by a LÄGLER®-approved workshop.

The service passport inside the back cover of these operating instructions (*Section 12*) documents when and where you have had your machine serviced.

**Please enter the serial number and the year of construction of your machine in the space provided on the back cover of these operation instructions (please see the rating plate). If you do not do this, the service passport is invalid.**

Ensure that maintenance work is recorded in the service passport by completing the relevant box with date, stamp and signature.

# Troubleshooting

## MACHINE FAILS TO START UP

---

### The machine fails to start up

- The guide tube is in the vertical position.
- To start the machine, pull both start levers towards you at **the same time**.
- Check the power supply, connect if applicable (Is the extension cable plug in a wall socket? Have the motor cable and the extension cable been disconnected from each other?).
- Check the fuses.
- Have the electrical equipment tested by a qualified electrician (e.g. capacitors, contactor, relays, cable and switches).
- The thermal switch has tripped. Allow the machine to cool down.

### The machine attempts to start up but is inhibited

- At low temperatures: allow the machine to warm up to room temperature in a warm room.
- Insufficient voltage: check the lead quality and length. Insufficiently dimensioned cable cross-sections (strand dia. less than 2.5 sq.mm) and excessively long supply lines should be avoided, if necessary use a transformer (Part. no. 708.00.00.100 for 230 Volts).

## MACHINE RUNS BADLY

---

### The machine runs but with no or insufficient sanding effect

- At low temperatures: allow the machine to warm up to room temperature in a warm room.
- Insufficient voltage: check the lead quality and length. Insufficiently dimensioned cable cross-sections (strand dia. less than 2.5 sq.mm) and excessively long supply lines should be avoided, if necessary use a transformer (Part. no. 708.00.00.100 for 230 Volts).
- Check that the drive elements are not blocking or sticking.
- Incorrect or blunt sanding abrasive.

**This section indicates how possible errors can be remedied. Should the actions outlined here fail to bring about a solution to the problem, please do not hesitate to contact our Customer Services Department, which will be pleased to advise you. Our fully trained and qualified service technicians are very familiar with the SINGLE and will be able to provide any assistance you may need.**

---

 GENERAL SAFETY REMARKS
 

---

**The machine is creating excessive noise and vibrations**

- Check the sanding disc for damage.
- Check that the sanding disc is positioned in the centre of the sanding plate.
- Check the flexible underlay between the sanding plate and sanding disc for damage.
- Check the machine for blockages and build-up of deposits.

**The machine runs well but creates dust**

- Check the suction system for blockages and clean if necessary.
- More than one sanding disc has been mounted.

**Sanding effect is not satisfactory**

- The machine is being moved too slowly.
- Too much additional pressure is being exerted.
- The machine is being moved incorrectly (i.e. not in a circular movement).
- The sanding disc has not been mounted properly.

## General safety remarks

**NOTE:**

**When working with power tools and machines, the following fundamental safety measures must be observed at all times in order to protect against electric shocks and danger of fire and injury. Read and remember these instructions before using the machine. Take good care of these safety instructions and keep them to hand at all times!**

**Keep the work area tidy**

Untidiness in the work area is a potential safety hazard.

**Be aware of environmental influences**

Never leave the machine out in the rain. Do not use the machine in humid or wet atmospheres. Ensure that good lighting is provided. Never use the machine close to sources of fire, combustible fluids or gases.

**Keep away from sources of fire. Do not smoke when there is dust in the atmosphere (e.g. while working with the machine or emptying out the dust) → this could cause a dust explosion.**

**Guard against electric shocks**

Avoid physical contact with earthed components such as pipes, radiators, stoves and fridges. Use the DI safety plug (For part nos. please see *Section 11, Spare parts*).

---

## GENERAL SAFETY REMARKS

---

**Keep children and unauthorised persons at a distance**

Do not allow children or any unauthorised persons to touch the machine or the cable, keep them away from the work area.

**Keep the machine in a safe place**

Machines that are not in use should be kept in a dry, locked location out of the reach of children.

**Do not overload the machine**

You will be able to work better and more safely within the specified performance range.

**Use the right machine**

Do not subject underpowered machines or attachments to excessive work loads. Refrain from using machines for purposes and work for which they are not intended.

**Wear suitable work clothing**

Do not wear loose clothing or jewellery which could get caught in moving parts of the equipment.

**Use safety gear**

Use respiratory masks with filter class P3 when working in dust-laden atmospheres.

**Only use the cable for its intended purpose**

Never use the cable to carry or pull the machine, or to pull the plug out of the socket. Protect the cable from the effects of heat, oil and sharp edges.

**Never bend too far over the machine**

Avoid any abnormal posture. Make sure you are standing steadily, keeping your balance at all times.

**Take good care of your machine**

Keeping your machine clean will allow you to work more efficiently and safely. Comply with the maintenance regulations and the tool changing instructions. Check the cables regularly and have them replaced by a qualified expert if damaged. Check extension cables regularly and replace if damaged. Keep the handles dry and free of oil and grease.

**Pull the plug out of the socket**

When the machine is not in use, before performing maintenance work and when changing tools, the mains plug must be pulled out of the socket.

**NOTE:**

**For your own safety, only use accessories and attachments which are specified in the operating instructions or offered in the relevant catalogue. The use of other tools or accessories than those recommended in the operating instructions can result in danger of personal injury.**

**Take care of these instructions and keep them within easy reach.**

**Observe the valid regulations of your employers' liability insurance association.**

**Never leave setting tools in the machine**

Before switching on, always check that you have removed all spanners and setting tools.

**Avoid unintentional start-up**

Ensure that the ON/OFF switch is not activated when connecting the machine to the mains.

**Be alert to potential dangers**

Always concentrate on what you are doing. Act sensibly, never use the machine when you are having difficulty concentrating.

**Check your machine for damage**

Before making further use of the machine, check the safety devices or damaged parts with care and test that all machine functions are in correct working order. Check whether moving parts are working correctly, whether they are jamming, whether any parts are broken, whether all other parts are correctly mounted and all other conditions which could influence operation of the machine are correct.

Unless otherwise specified in the operating instructions, damaged safety devices and parts must be repaired or replaced professionally by an after-sales workshop. Damaged switches must be replaced by an after-sales workshop. Never use machines with switches which cannot be turned on or off.



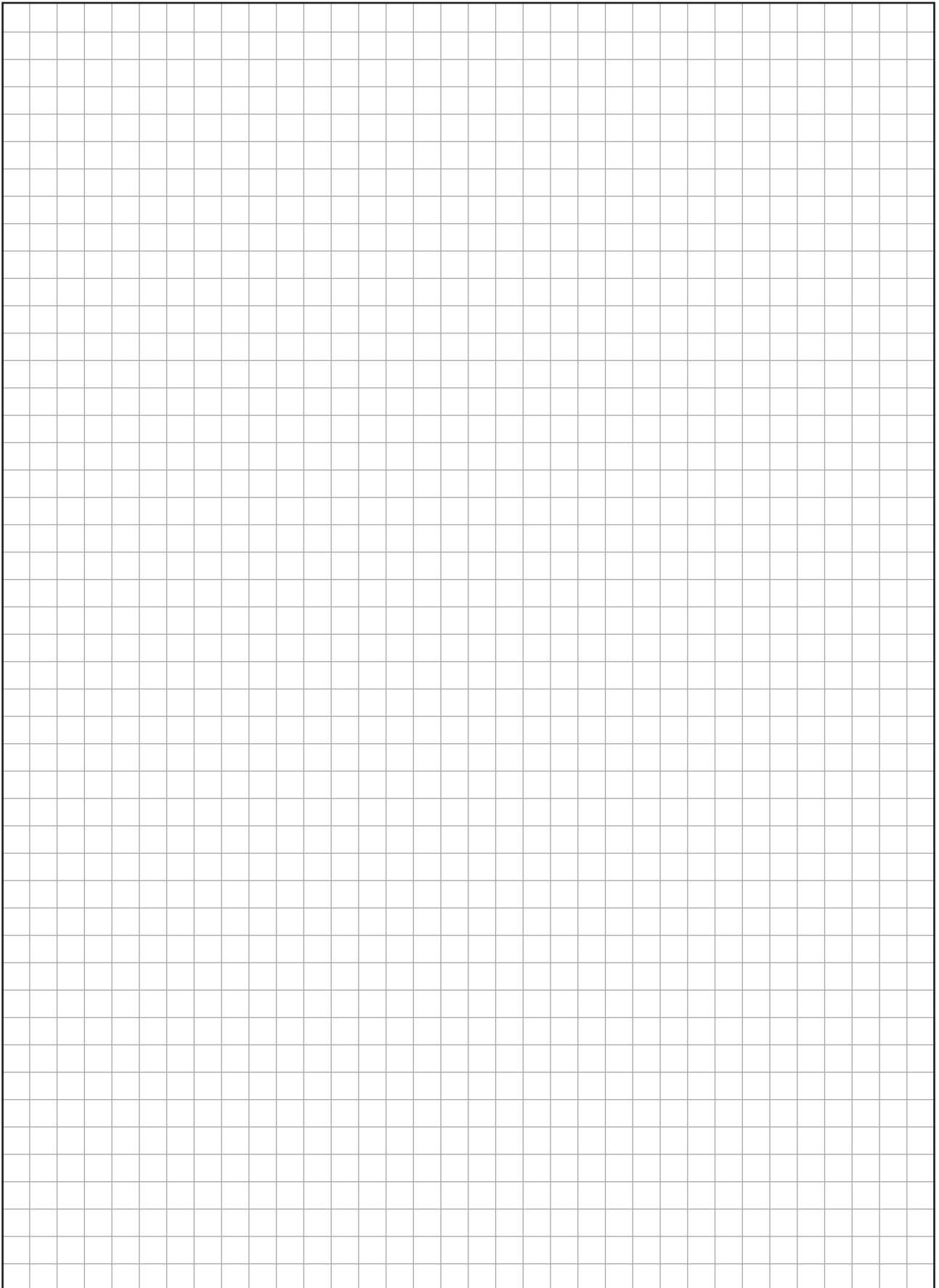

CIRCUIT DIAGRAMS

K1 = Contactor  
 K2 = Relay  
 F1 = Fuse  
 S1 = Switch

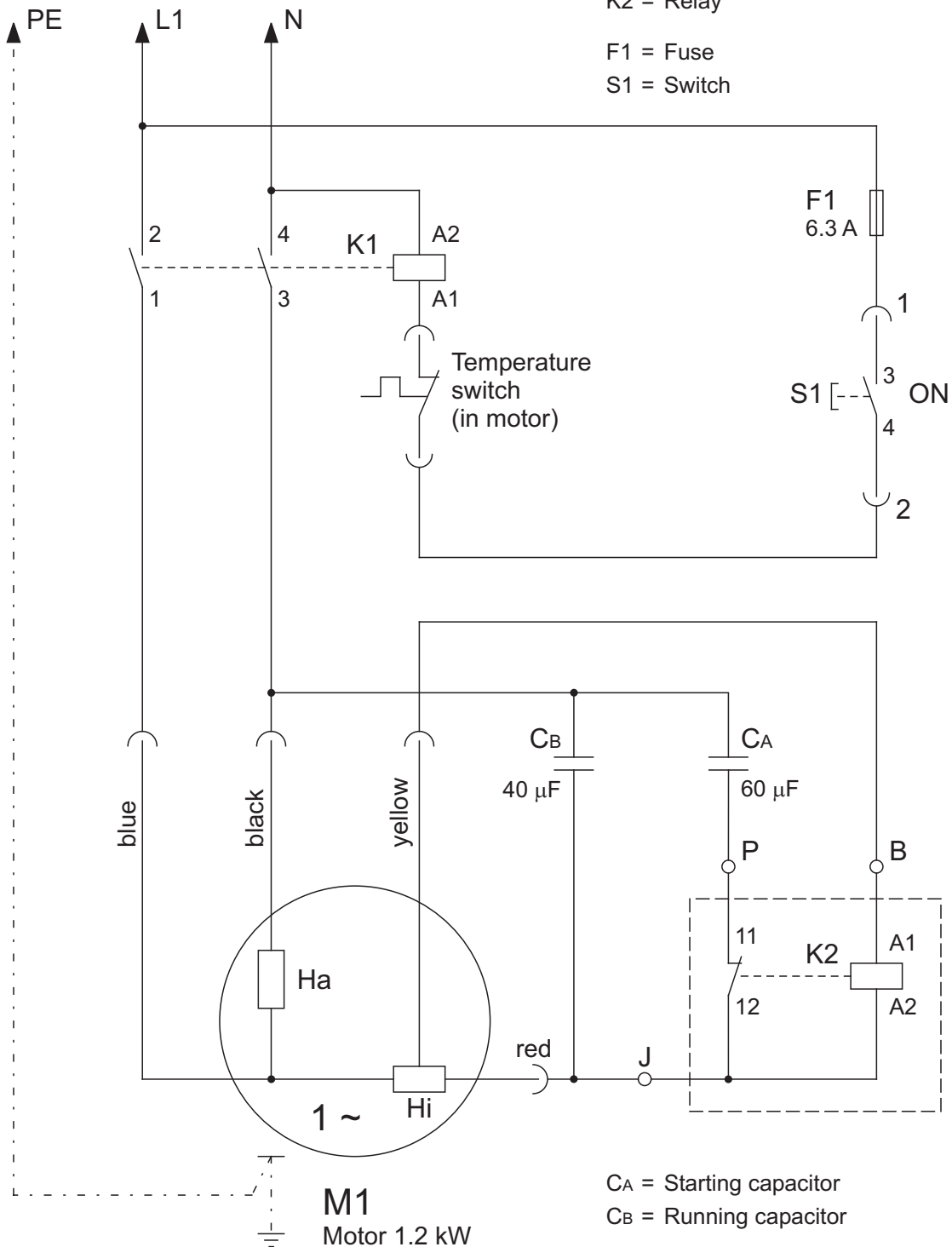

**M1**  
 Motor 1.2 kW  
 230 V / 50 CPS  
 230 V / 60 CPS

CA = Starting capacitor  
 CB = Running capacitor  
 Ha = Main winding  
 Hi = Auxiliary winding

01.09.2006

**SINGLE: Single-phase AC motor**

1.2 kW / 230 V / 50 CPS  
 1.2 kW / 230 V / 60 CPS

EUGEN LÄGLER GMBH  
 Kappelrain 2  
 D-74363 Güglingen-Frauenzimmern

Phone: 0049 - 7135 - 98 90 - 0  
 Fax: 0049 - 7135 - 98 90 - 98

E-mail: info@laegler.com  
 Internet: http://www.laegler.com

CIRCUIT DIAGRAMS

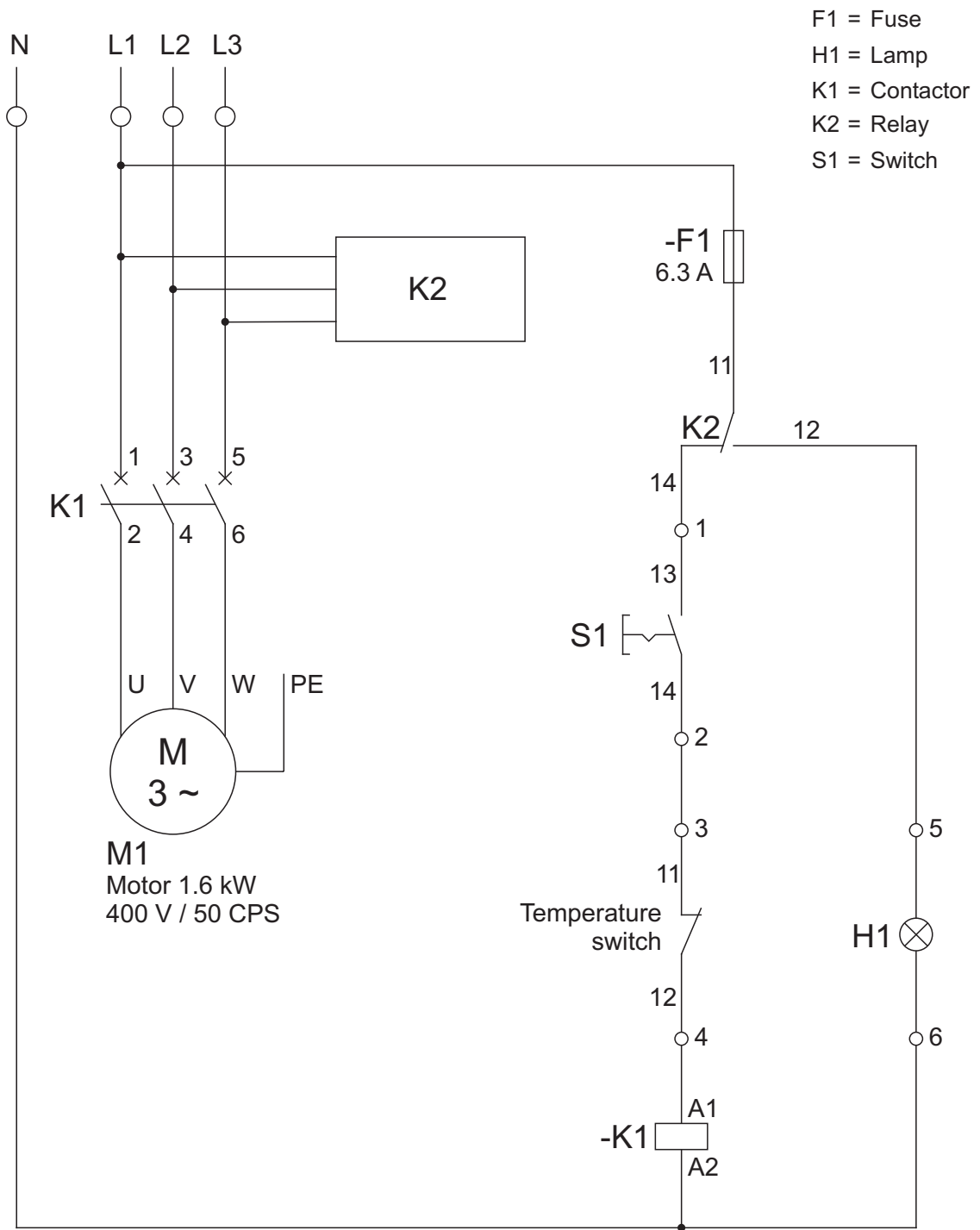

Correct rotating direction of the motor:  
 Look to the gear unit    Look to the fan wheel



01.06.2008

|  |   |  |
|--|---|--|
| SINGLE: Three-phase AC motor   |   | 1.6 kW / 400 V / 50 CPS                                      |
| EUGEN LÄGLER GMBH<br>Kappelrain 2<br>D-74363 Güglingen-Frauenzimmern | Phone: 0049 - 7135 - 98 90 - 0<br>Fax: 0049 - 7135 - 98 90 - 98 | E-mail: info@laegler.com<br>Internet: http://www.laegler.com |

SPARE PARTS

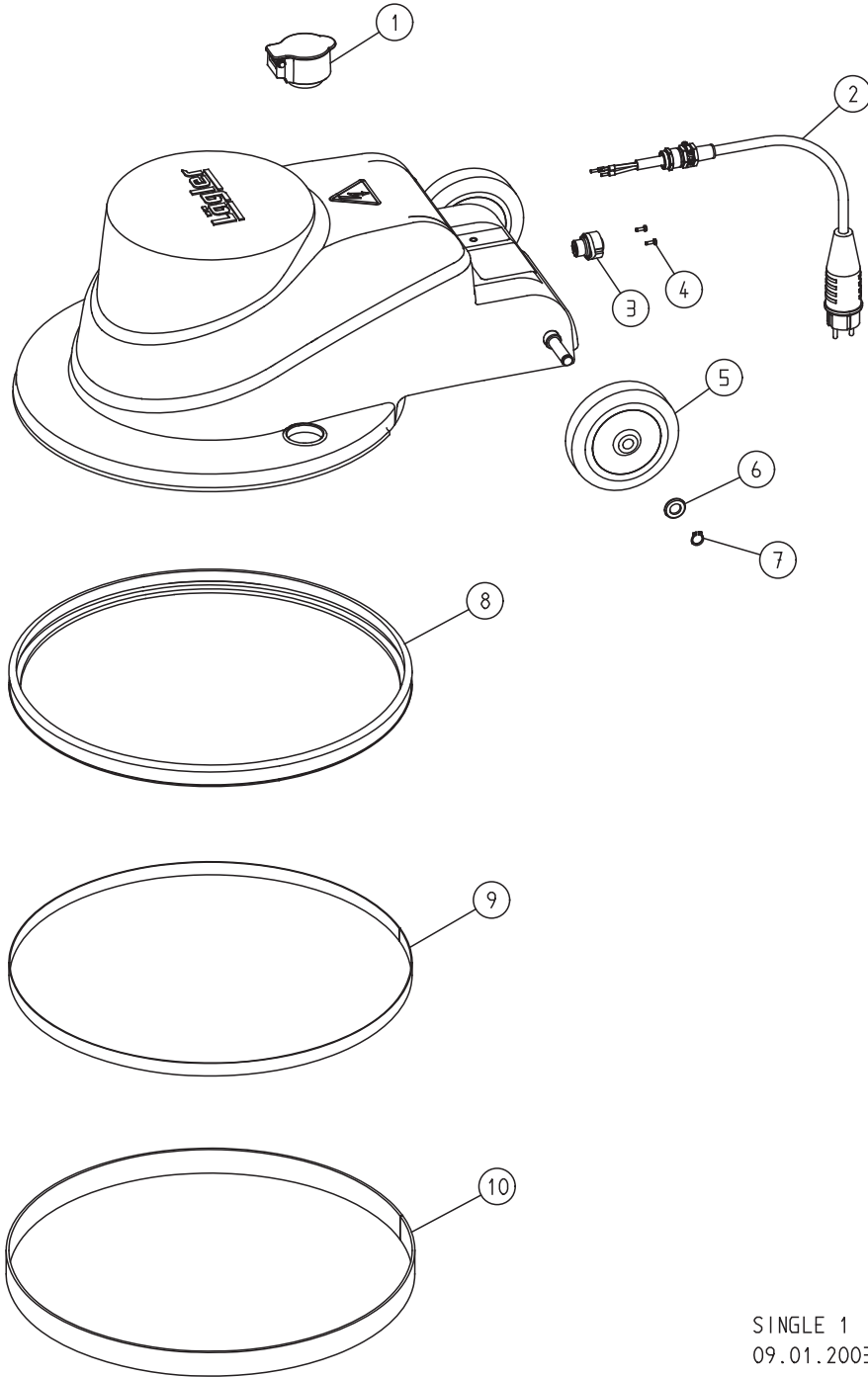

SINGLE 1  
09.01.2003

## SPARE PARTS

| Item | Part number   | Description                         |
|------|---------------|-------------------------------------|
| 1    | 850.01.80.200 | Dust extraction socket              |
| 2    | 000.65.43.252 | Motor cable 3 x 2.5 mm <sup>2</sup> |
| 3    | 000.65.71.040 | Integrated socket                   |
| 4    | 7500.1003.010 | Screw                               |
| 5    | 850.05.09.105 | Wheel                               |
| 6    | 0125.1012.000 | Washer                              |
| 7    | 0471.0012.000 | Circlip                             |
| 8    | 850.01.02.105 | Buffer                              |
| 9    | 850.01.40.100 | Velcro                              |
| 10   | 850.01.51.100 | Fluffy sealing strip                |

SPARE PARTS

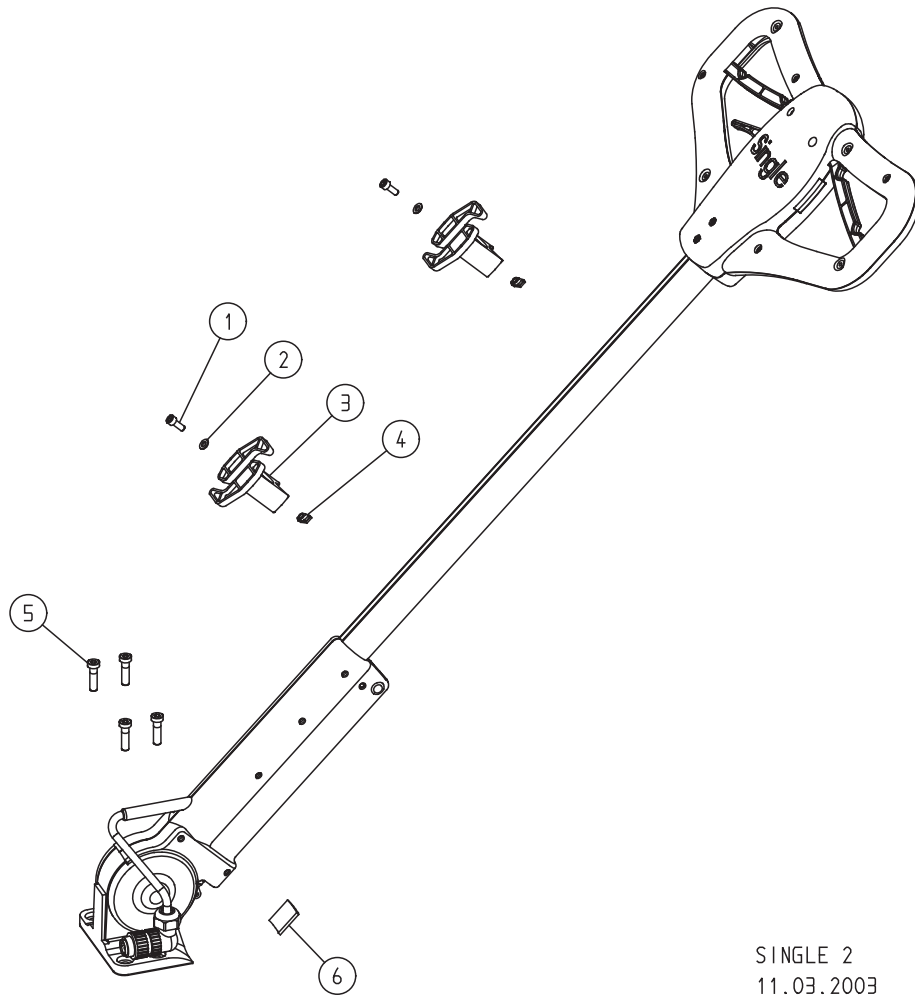

SINGLE 2  
11.03.2003

## SPARE PARTS

| Item | Part number   | Description   |
|------|---------------|---------------|
| 1    | 0912.1006.016 | Screw         |
| 2    | 0125.1006.000 | Washer        |
| 3    | 850.20.28.105 | Cable holder  |
| 4    | 850.20.29.100 | Sliding block |
| 5    | 7984.1008.030 | Screw         |
| 6    | 900.70.25.105 | Bumper felt   |

SPARE PARTS

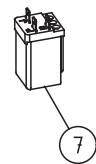
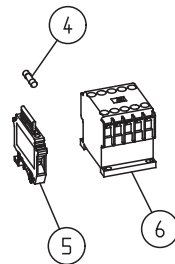
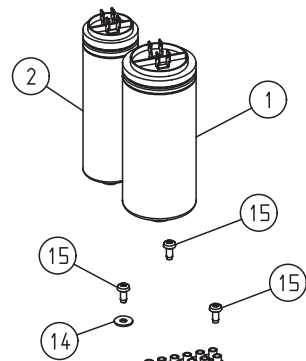
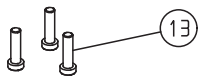
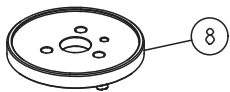
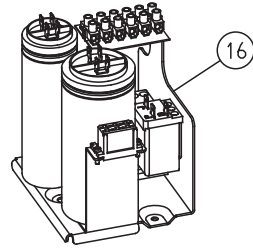
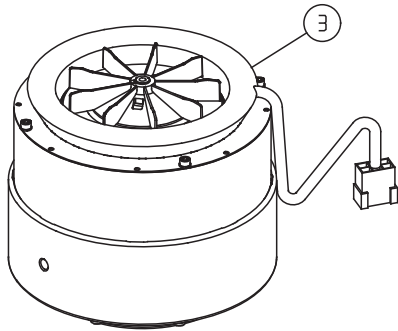

SINGLE 3  
01.01.2013



## SPARE PARTS

| Item | Part number   | Description                                     |
|------|---------------|---|
| 1    | 000.65.10.041 | Running capacitor 40 $\mu$ F                    |
| 2    | 000.65.10.061 | Starting capacitor 60 $\mu$ F                   |
| 3    | 850.65.00.200 | Motor, 230 V / 50 CPS / 1.2 kW                  |
| 4    | 000.65.80.061 | Fuse, 6.3 A                                     |
| 5    | 000.65.82.010 | Fuse holder                                     |
| 6    | 000.65.20.012 | Contacto  |
| 7    | 000.65.20.230 | Relay   |
| 8    | 850.64.06.100 | Adapter mounting                                |
| 9    | 850.64.07.205 | Shock absorber                                  |
| 10   | 850.64.08.100 | Plate mounting                                  |
| 11   | 1481.0006.032 | Spring type straight pin                        |
| 12   | 6797.1008.000 | Washer  |
| 13   | 7984.1008.030 | Screw   |
| 14   | 9021.1005.000 | Washer  |
| 15   | 7500.1005.012 | Screw   |
| 16   | 850.65.80.100 | Control electric system complete, 230 V / 50 Hz |

## SPARE PARTS

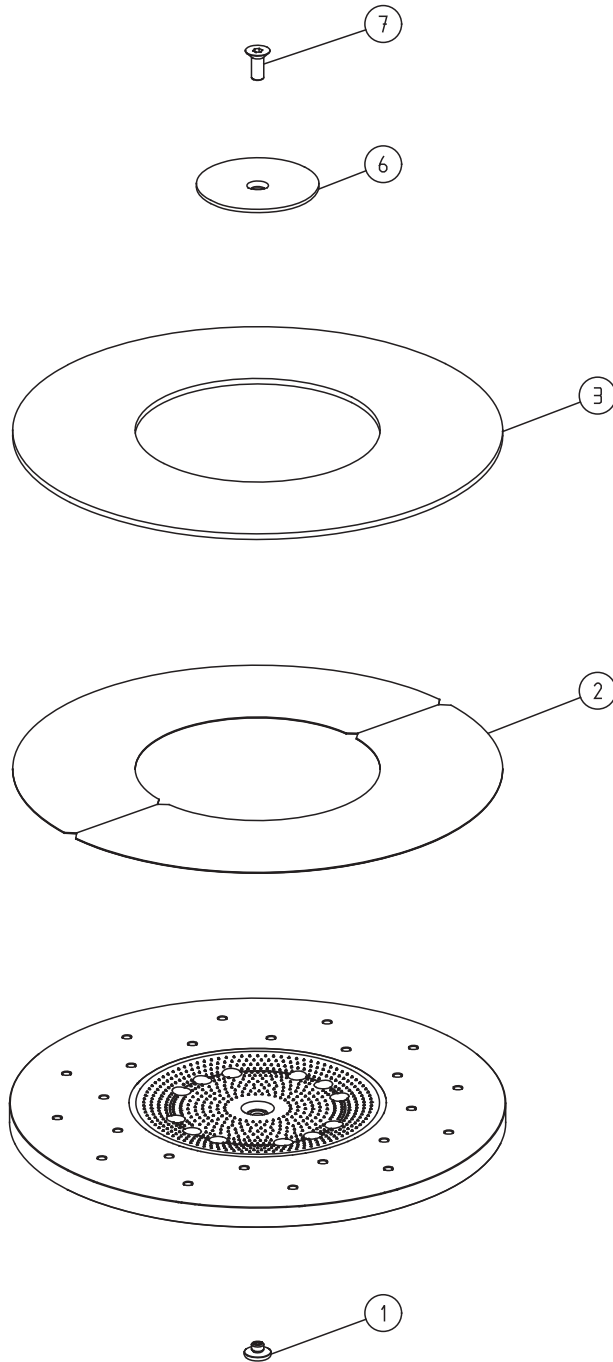

SINGLE 4  
01.01.2010

## SPARE PARTS

| Item | Part number   | Description   |
|------|---------------|---|
|      | 850.02.10.100 | Sanding plate SINGLE complete   |
| 1    | 850.02.06.200 | Centering dome  |
| 2    | 850.02.11.100 | Velcro coating, for pad and Velcro sanding disc (two parts necessary) |
| 3    | 850.02.13.105 | Velcro ring flexible  |
| 6    | 850.02.05.100 | Paper tensioning disc   |
| 7    | 7991.1010.725 | Screw, left-handed thread   |

SPARE PARTS

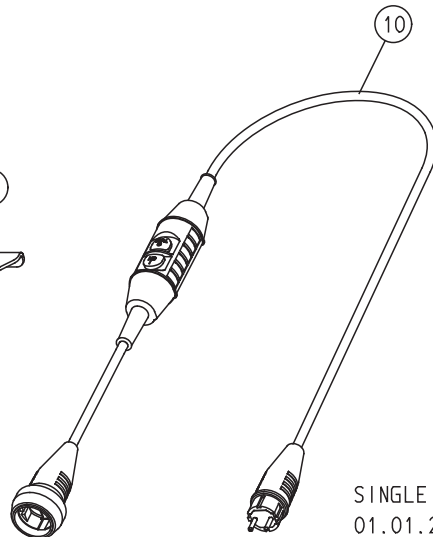
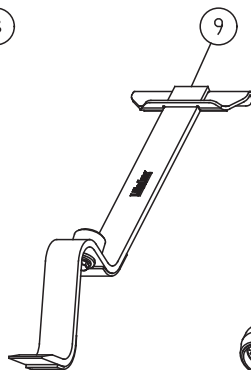
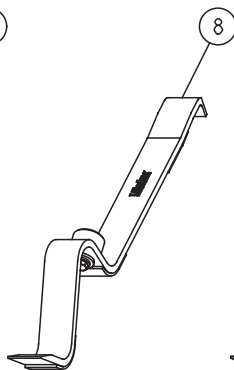
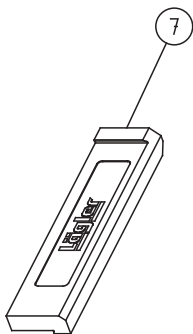
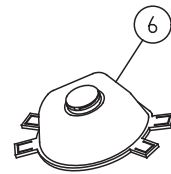
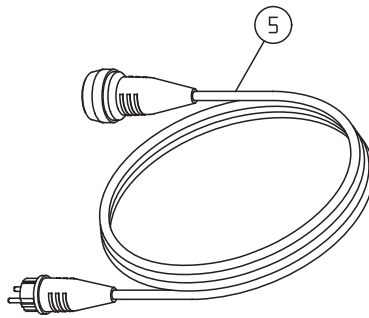
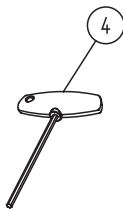
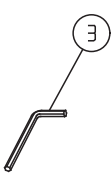
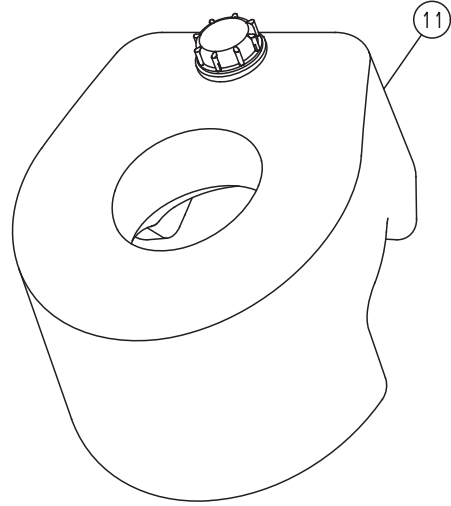
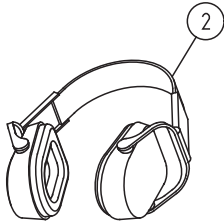
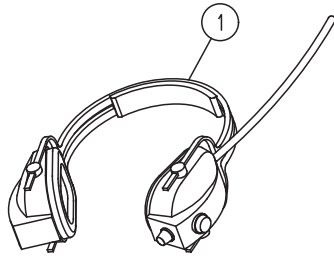

SINGLE 5  
01.01.2008

## SPARE PARTS

| Item | Part number   | Description   |
|------|---------------|---|
| 1    | 000.01.10.011 | Foldable earmuff type MUSIMUFF with FM radio        |
| 2    | 000.01.10.021 | Foldable earmuff type POCKET                        |
| 3    | 000.93.11.061 | Hexagonal socket screw wrench 6 mm                  |
| 4    | 000.93.12.052 | Hexagonal socket screw wrench 5 x 150 mm            |
| 5    | 000.65.53.251 | Extension cable 3 x 2.5 mm <sup>2</sup> , 10 m long |
| 6    | 000.01.20.010 | Respiratory protection mask P3                      |
| 7    | 701.10.00.100 | Impact tool   |
| 8    | 702.00.00.200 | Parquet layer tool ZUGEISEN, small                  |
| 9    | 703.00.00.200 | Parquet layer tool ZUGEISEN, broad                  |
| 10   | 000.01.65.020 | Safety switch PRCD-S (for German mains supply)      |
| 11   | 850.80.10.105 | Additional weight SINGLE                            |

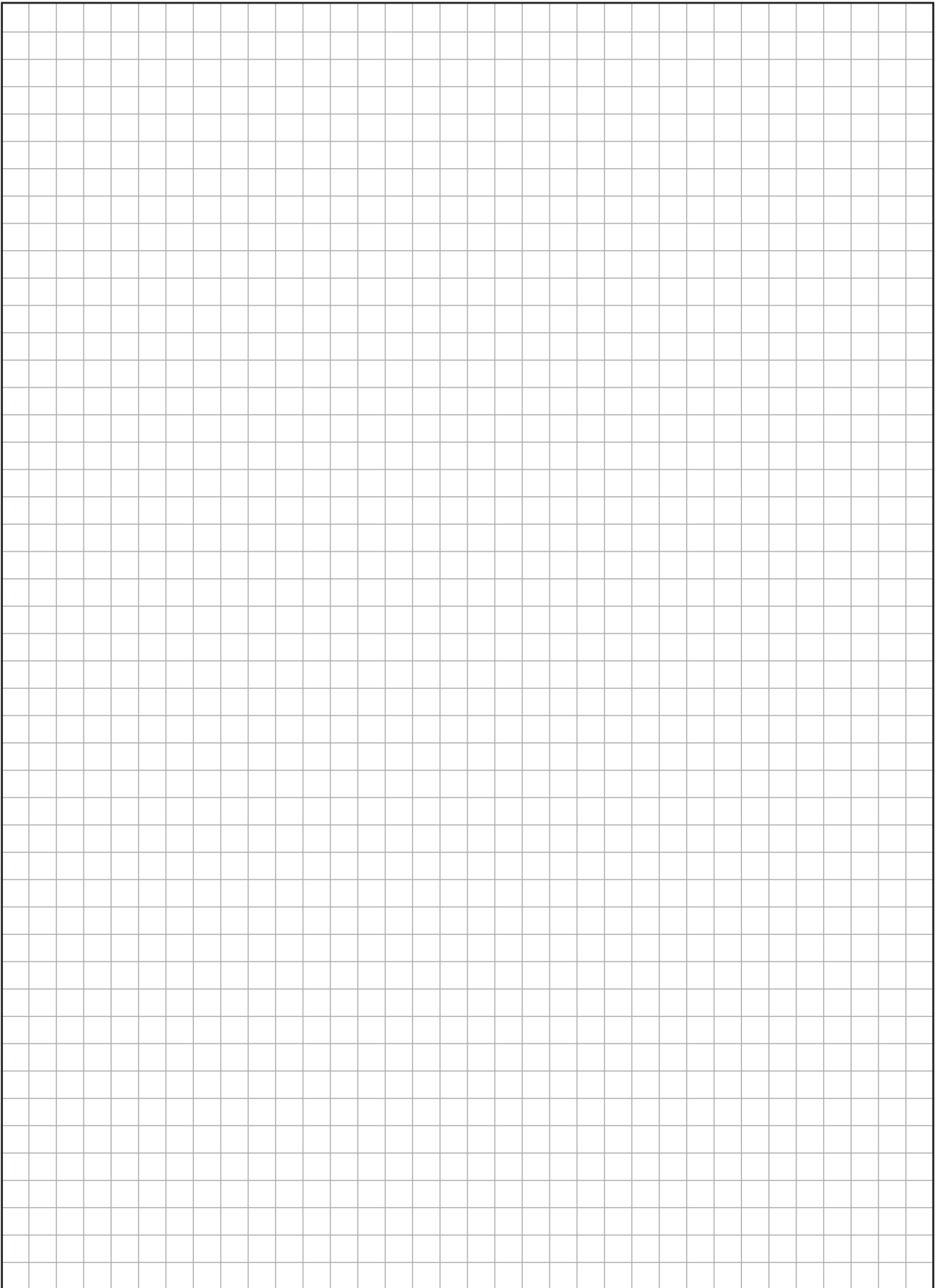

# Service passport

**Please enter the serial number and the year of manufacture of your machine on the rear side of these operating instructions (see type plate)! Otherwise the service passport will not be valid!**

This service passport is a document. Make sure that all the tests and maintenance work carried out on the machine are confirmed by the servicing company here.

|   |   |   |
|---|---|---|
| <b>Date of test and maintenance work:</b> _____<br><br><br><br><br><br><br><br><br><br><b>Signature and company stamp</b> | <b>Date of test and maintenance work:</b> _____<br><br><br><br><br><br><br><br><br><br><b>Signature and company stamp</b> | <b>Date of test and maintenance work:</b> _____<br><br><br><br><br><br><br><br><br><br><b>Signature and company stamp</b> |
| <b>Date of test and maintenance work:</b> _____<br><br><br><br><br><br><br><br><br><br><b>Signature and company stamp</b> | <b>Date of test and maintenance work:</b> _____<br><br><br><br><br><br><br><br><br><br><b>Signature and company stamp</b> | <b>Date of test and maintenance work:</b> _____<br><br><br><br><br><br><br><br><br><br><b>Signature and company stamp</b> |
| <b>Date of test and maintenance work:</b> _____<br><br><br><br><br><br><br><br><br><br><b>Signature and company stamp</b> | <b>Date of test and maintenance work:</b> _____<br><br><br><br><br><br><br><br><br><br><b>Signature and company stamp</b> | <b>Date of test and maintenance work:</b> _____<br><br><br><br><br><br><br><br><br><br><b>Signature and company stamp</b> |
| <b>Date of test and maintenance work:</b> _____<br><br><br><br><br><br><br><br><br><br><b>Signature and company stamp</b> | <b>Date of test and maintenance work:</b> _____<br><br><br><br><br><br><br><br><br><br><b>Signature and company stamp</b> | <b>Date of test and maintenance work:</b> _____<br><br><br><br><br><br><br><br><br><br><b>Signature and company stamp</b> |
| <b>Date of test and maintenance work:</b> _____<br><br><br><br><br><br><br><br><br><br><b>Signature and company stamp</b> | <b>Date of test and maintenance work:</b> _____<br><br><br><br><br><br><br><br><br><br><b>Signature and company stamp</b> | <b>Date of test and maintenance work:</b> _____<br><br><br><br><br><br><br><br><br><br><b>Signature and company stamp</b> |

# EU Declaration of conformity for machines (EU Directive 2006/42/EC)

The manufacturer **Eugen Lägler GmbH, Kappelrain 2, D-74363 Güglingen-Frauenzimmern**  
Tel.: 0049 - (0)7135 - 98 90-0 · Fax: 0049 - (0)7135 - 98 90-98  
E-Mail: info@laegler.com · http://www.laegler.com

certified herewith, that the machine Generic denomination: **Floor sanding machine**  
Function: **Dry sanding of wooden floors**  
Model: **SINGLE**  
Serial number: **See type plate**  
Commercial name: **Single-disc sanding machine**

fulfils all the relevant provisions of the specified above European Directive.

The machine also fulfils all the relevant provisions of the European Directive  
**Electromagnetic compatibility (2004/108/EG).**

**The following harmonized standards have been applied:**

**DIN EN ISO 12100:** Safety of machinery - General principles for design - Risk assessment and risk reduction

**DIN EN 60204-1:** Safety of machinery - Electrical equipment of machines - Part 1

**DIN EN 55014-1:** Electromagnetic compatibility - Requirements for household appliances, electric tools and similar apparatus - Part 1

**DIN EN 55014-2:** Electromagnetic compatibility - Requirements for household appliances, electric tools and similar apparatus - Part 2

**DIN EN 61000-3-2:** Electromagnetic compatibility (EMC) - Part 3-2: Limits

**DIN EN 61000-3-3:** Electromagnetic compatibility (EMC) - Part 3-3: Limits

Güglingen-Frauenzimmern, February 1, 2013

*Volker Wörner*

Dipl.-Ing. (FH) Volker Wörner, Design Engineer

Person Responsible for Documents

Eugen Lägler GmbH, Kappelrain 2

D-74363 Güglingen-Frauenzimmern

**SINGLE**

**Serial number:**

**Year of manufacture:**