

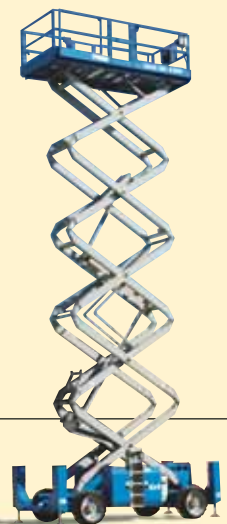

# Rough Terrain Self-Propelled Scissor Lift

GS™-4390 RT  
GS™-5390 RT

- Ready to tackle the most rigorous job sites with superior gradeability and traction-controlled four-wheel drive.



**Genie Industries**

## GS-4390 RT and GS-5390 RT

- Large platform with durable diamond-plate aluminum flooring. A single 60 in (1.52 m) multi-position slide-out extension deck, on the front of the machine, comes standard. A second 48 in (1.22 m) slide-out extension deck, on the rear of the machine, is available as an option.
- Rear platform railing can be removed for easier loading and unloading of materials.
- Slide-out engine tray allows easy access to components.
- Automatic leveling hydraulic outriggers are standard on the GS-5390 RT, optional on the GS-4390 RT.

### Standard Features

- GS-4390 has 49 ft (15.1 m) working height and GS-5390 RT has 59 ft (18.2 m) working height
- 1,500 lb (680 kg) load capacity
- Positive traction-controlled four-wheel drive
- Meets current emissions requirements
- 50% gradeability
- Proportional drive/lift
- Two-speed lift functions
- Troubleshooting diagnostics
- Two self-closing entry gates
- Foam-filled tires
- AC wiring to platform
- Descent alarm
- Tilt sensor with an audible alarm
- Horn
- Hour meter



### Options and Accessories

- Motion alarm
- Dual flashing beacons
- Propane tank kit (single and/or additional)
- Dual slide-out extension deck package (front and rear)
- Hydraulic oil cooler
- 2,000 watt generator (110 volt/60 hz)
- Automatic leveling hydraulic outriggers (GS-4390 RT)
- Non-marking tires

### Standards Compliance

- ANSI/SIA A92.6
- CSA CAN3-B354.2
- CE compliance option
- AS 1418.10

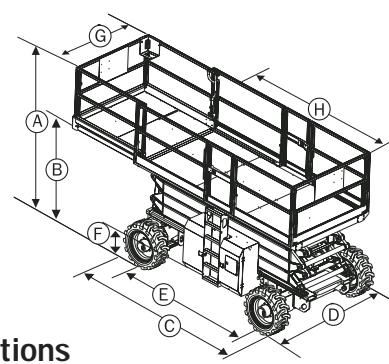

### Specifications

Model	GS-4390 RT		GS-5390 RT	
	US	Metric	US	Metric
Working height**	49 ft	15.1 m	59 ft	18.2 m
Platform height	43 ft	13.1 m	53 ft	16.2 m
(A) Height – stowed				
guardrails	115 ½ in	2.93 m	124 in	3.15 m
guardrails lowered	88 ¾ in	2.25 m	97 ¼ in	2.47 m
(B) Height – stowed (platform)	71 in	1.80 m	79 ½ in	2.02 m
(C) Length – stowed				
w/ single deck extension	155 ¼ in	3.94 m	n/a	n/a
w/ dual deck extension	156 ½ in	3.98 m	n/a	n/a
w/ outriggers	192 in	4.88 m	192 in	4.88 m
(D) Width	90 in	2.29 m	90 in	2.29 m
(E) Wheelbase	112 in	2.84 m	112 in	2.84 m
(F) Ground clearance	14 in	36 cm	14 in	36 cm
(G) Platform width	72 in	1.83 m	72 in	1.83 m
(H) Platform length				
single deck extended	210 ½ in	5.34 m	210 ½ in	5.34 m
dual decks extended	258 ½ in	6.57 m	258 ½ in	6.57 m
Slide-out deck extension(s)				
standard front deck	60 in	1.52 m	60 in	1.52 m
optional rear deck	48 in	1.22 m	48 in	1.22 m
Lift capacity	1,500 lb	680 kg	1,500 lb	680 kg
Extension deck capacity (max)	500 lb	227 kg	500 lb	227 kg
Turning radius – outside	210 in	5.33 m	210 in	5.33 m
Turning radius – inside	85 in	2.16 m	85 in	2.16 m
Power source	Ford Gas/LPG 82 hp (61 kw) Deutz Diesel 49 hp (36 kw)			
Auxiliary power unit	12V DC	12V DC	12V DC	12V DC
Drive speed – stowed	5 mph	8.0 km/h	5 mph	8.0 km/h
Drive speed – raised	0.7 mph	1.1 km/h	0.7 mph	1.1 km/h
Raise/lower speed	45 sec / 39 sec		55 sec / 49 sec	
Self-leveling capability w/ outriggers				
- side/side	10°		10°	
- front/rear	7.2°		7.2°	
Controls	Proportional drive/lift			
Tires	12-21.5 NHS foam filled			
Gradeability (4x4)	50%		40%	
Drive	four wheel			
Multiple disc brakes	dual rear wheel			
Fuel tank capacity	30 gal	114 litre	30 gal	114 litre
Hydraulic tank capacity	30 gal	114 litre	30 gal	114 litre
Weight *	13,086 lb	5,936 kg	16,616 lb	7,537 kg

#### Unit weight modifiers for options

\* Basic unit consists of dual fuel, 4-wheel drive with one extension deck. GS-5390 RT basic unit includes weight of outriggers.

Diesel	add 0 lb	add 0 kg
Outriggers	add 1,930 lb	add 875 kg
Dual extension decks	add 295 lb	add 134 kg
CE link guard	add 180 lb	add 82 kg

\*\*The metric equivalent of working height adds 2 m to platform height. U.S. adds 6 ft to platform height.

Distributed By:

## Genie Industries

#### GENIE UNITED STATES

18340 NE 76th Street  
P.O. Box 97030  
Redmond, Washington 98073-9730  
Telephone (425) 881-1800  
Toll Free in USA/Canada 800-536-1800  
Fax (425) 883-3475  
http://www.genieindustries.com

#### GENIE UNITED KINGDOM

The Maltings, Wharf Road  
Grantham  
Lincolnshire NG31 6BH  
England  
Telephone: +44 (0)1476 584333  
Fax: +44 (0)1476 584334  
http://www.genieindustries.com