

MAST SPECIFICATIONS and RATED CAPACITIES

B15T-7

Mast type	Maximum Fork Height	Fully Lowered Height	Fully Extended Height		Free Lift		Rated Load Capacities					
			with Load Backrest	without Load Backrest	with Load Backrest	without Load Backrest	Single Solid Tire			Single Cushion Tire		
							Tilt Angle		Load Cap.	Tilt Angle		Load Cap.
							FWD	BWD	LC 500mm	FWD	BWD	LC 500mm
mm	mm	mm	mm	mm	mm	deg	deg	kg	deg	deg	kg	
STD	3,000	2,000	4,045	3,600	130	130	5	7	1,500	5	7	1,500
	3,300	2,150	4,345	3,900	130	130	5	7	1,500	5	7	1,500
	3,500	2,250	4,545	4,100	130	130	5	7	1,500	5	7	1,500
	3,700	2,350	4,745	4,300	130	130	5	7	1,500	5	7	1,500
	4,000	2,550	5,045	4,600	130	130	5	7	1,500	5	7	1,500
4,500	2,800	5,545	5,100	130	130	5	7	1,425	5	7	1,450	
FF	2,700	1,850	3,745	3,325	845	1,265	5	5	1,500	5	5	1,500
	3,000	2,000	4,045	3,625	995	1,415	5	5	1,500	5	5	1,500
	3,300	2,150	4,345	3,925	1,145	1,565	5	5	1,500	5	5	1,500
FFT	4,000	1,880	5,050	4,630	875	1,295	5	5	1,450	5	5	1,475
	4,500	2,045	5,545	5,125	1,040	1,460	5	5	1,400	5	5	1,425
	4,750	2,130	5,795	5,375	1,125	1,545	5	5	1,350	5	5	1,375
	5,000	2,245	6,045	5,625	1,240	1,660	5	5	1,300	5	5	1,350
	5,500	2,480	6,550	6,130	1,475	1,895	5	5	975	5	5	1,275
	6,000	2,645	7,045	6,625	1,640	2,060	5	5	650	5	5	1,225

B18T-7, B18TL-7

Mast type	Maximum Fork Height	Fully Lowered Height	Fully Extended Height		Free Lift		Rated Load Capacities					
			with Load Backrest	without Load Backrest	with Load Backrest	without Load Backrest	Single Solid Tire			Single Cushion Tire		
							Tilt Angle		Load Cap.	Tilt Angle		Load Cap.
							FWD	BWD	LC 500mm	FWD	BWD	LC 500mm
mm	mm	mm	mm	mm	mm	deg	deg	kg	deg	deg	kg	
STD	3,000	2,000	4,045	3,600	130	130	5	7	1,750	5	7	1,750
	3,300	2,150	4,345	3,900	130	130	5	7	1,750	5	7	1,750
	3,500	2,250	4,545	4,100	130	130	5	7	1,750	5	7	1,750
	3,700	2,350	4,745	4,300	130	130	5	7	1,750	5	7	1,750
	4,000	2,550	5,045	4,600	130	130	5	7	1,750	5	7	1,750
4,500	2,800	5,545	5,100	130	130	5	7	1,650	5	7	1,650	
FF	2,700	1,850	3,745	3,325	845	1,265	5	5	1,750	5	5	1,750
	3,000	2,000	4,045	3,625	995	1,415	5	5	1,750	5	5	1,750
	3,300	2,150	4,345	3,925	1,145	1,565	5	5	1,750	5	5	1,750
FFT	4,000	1,880	5,050	4,630	875	1,295	5	5	1,675	5	5	1,700
	4,500	2,045	5,545	5,125	1,040	1,460	5	5	1,600	5	5	1,650
	4,750	2,130	5,795	5,375	1,125	1,545	5	5	1,525	5	5	1,625
	5,000	2,245	6,045	5,625	1,240	1,660	5	5	1,400	5	5	1,575
	5,500	2,480	6,550	6,130	1,475	1,895	5	5	1,025	5	5	1,500
	6,000	2,645	7,045	6,625	1,640	2,060	5	5	700	5	5	1,400

B20T-7, B20TL-7

Mast type	Maximum Fork Height	Fully Lowered Height	Fully Extended Height		Free Lift		Rated Load Capacities					
			with Load Backrest	without Load Backrest	with Load Backrest	without Load Backrest	Single Solid Tire			Single Cushion Tire		
							Tilt Angle		Load Cap.	Tilt Angle		Load Cap.
							FWD	BWD	LC 500mm	FWD	BWD	LC 500mm
mm	mm	mm	mm	mm	mm	deg	deg	kg	deg	deg	kg	
STD	3,000	2,000	4,050	3,605	135	135	5	7	2,000	5	7	2,000
	3,300	2,150	4,350	3,905	135	135	5	7	2,000	5	7	2,000
	3,500	2,250	4,550	4,105	135	135	5	7	2,000	5	7	2,000
	3,700	2,350	4,750	4,305	135	135	5	7	2,000	5	7	2,000
	4,000	2,550	5,050	4,605	135	135	5	7	2,000	5	7	2,000
4,500	2,800	5,550	5,105	135	135	5	7	1,950	5	7	2,000	
FF	2,700	1,850	3,750	3,330	845	1,265	5	5	2,000	5	5	2,000
	3,000	2,000	4,050	3,630	995	1,415	5	5	2,000	5	5	2,000
	3,300	2,150	4,350	3,930	1,145	1,565	5	5	2,000	5	5	2,000
FFT	4,000	1,880	5,055	4,635	875	1,295	5	5	1,950	5	5	2,000
	4,500	2,045	5,550	5,130	1,040	1,460	5	5	1,900	5	5	1,975
	4,750	2,130	5,800	5,380	1,125	1,545	5	5	1,825	5	5	1,925
	5,000	2,245	6,050	5,630	1,240	1,660	5	5	1,800	5	5	1,900
	5,500	2,480	6,555	6,135	1,475	1,895	5	5	1,700	5	5	1,800
	6,000	2,645	7,050	6,630	1,640	2,060	5	5	1,575	5	5	1,500

Note: These load capacities are based on the standard chassis without side shifter.

Specification values quoted in this catalog have been rounded.

Products and specifications are subject to improvement and change without notice.

Performance may vary due to operating conditions.

The performance shown represents nominal values obtained under typical operating conditions.

B16X-7

Mast type	Maximum Fork Height	Fully Lowered Height	Fully Extended Height		Free Lift		Rated Load Capacities					
			with Load Backrest	without Load Backrest	with Load Backrest	without Load Backrest	Single Solid Tire			Single Pneumatic Tire		
							Tilt Angle		Load Cap.	Tilt Angle		Load Cap.
							FWD	BWD	LC 500mm	FWD	BWD	LC 500mm
mm	mm	mm	mm	mm	mm	deg	deg	kg	deg	deg	kg	
STD	3,000	2,000	4,045	3,600	130	130	5	7	1,600	5	7	1,600
	3,300	2,150	4,345	3,900	130	130	5	7	1,600	5	7	1,600
	3,500	2,250	4,545	4,100	130	130	5	7	1,600	5	7	1,600
	3,700	2,350	4,745	4,300	130	130	5	7	1,600	5	7	1,600
	4,000	2,550	5,045	4,600	130	130	5	7	1,600	5	7	1,600
4,500	2,800	5,545	5,100	130	130	5	7	1,600	5	7	1,600	
FF	2,700	1,850	3,745	3,325	845	1,265	5	5	1,600	5	5	1,600
	3,000	2,000	4,045	3,625	995	1,415	5	5	1,600	5	5	1,600
	3,300	2,150	4,345	3,925	1,145	1,565	5	5	1,600	5	5	1,600
FFT	4,000	1,880	5,050	4,630	875	1,295	5	5	1,600	5	5	1,600
	4,500	2,045	5,545	5,125	1,040	1,460	5	5	1,550	5	5	1,525
	4,750	2,130	5,795	5,375	1,125	1,545	5	5	1,500	5	5	1,475
	5,000	2,245	6,045	5,625	1,240	1,660	5	5	1,450	5	5	1,450
	5,500	2,480	6,550	6,130	1,475	1,895	5	5	1,350	5	5	1,350
	6,000	2,645	7,045	6,625	1,640	2,060	5	5	1,250	5	5	1,075

B18X-7

Mast type	Maximum Fork Height	Fully Lowered Height	Fully Extended Height		Free Lift		Rated Load Capacities					
			with Load Backrest	without Load Backrest	with Load Backrest	without Load Backrest	Single Solid Tire			Single Pneumatic Tire		
							Tilt Angle		Load Cap.	Tilt Angle		Load Cap.
							FWD	BWD	LC 500mm	FWD	BWD	LC 500mm
mm	mm	mm	mm	mm	mm	deg	deg	kg	deg	deg	kg	
STD	3,000	2,000	4,045	3,600	130	130	5	7	1,800			
	3,300	2,150	4,345	3,900	130	130	5	7	1,800			
	3,500	2,250	4,545	4,100	130	130	5	7	1,800	n/a	n/a	n/a
	3,700	2,350	4,745	4,300	130	130	5	7	1,800			
	4,000	2,550	5,045	4,600	130	130	5	7	1,800			
4,500	2,800	5,545	5,100	130	130	5	7	1,700				
FF	2,700	1,850	3,745	3,325	845	1,265	5	5	1,800			
	3,000	2,000	4,045	3,625	995	1,415	5	5	1,800	n/a	n/a	n/a
	3,300	2,150	4,345	3,925	1,145	1,565	5	5	1,800			
FFT	4,000	1,880	5,050	4,630	875	1,295	5	5	1,800			
	4,500	2,045	5,545	5,125	1,040	1,460	5	5	1,750			
	4,750	2,130	5,795	5,375	1,125	1,545	5	5	1,600	n/a	n/a	n/a
	5,000	2,245	6,045	5,625	1,240	1,660	5	5	1,550			
	5,500	2,480	6,550	6,130	1,475	1,895	5	5	1,475			
	6,000	2,645	7,045	6,625	1,640	2,060	5	5	1,350			

B20X-7

Mast type	Maximum Fork Height	Fully Lowered Height	Fully Extended Height		Free Lift		Rated Load Capacities					
			with Load Backrest	without Load Backrest	with Load Backrest	without Load Backrest	Single Solid Tire			Single Pneumatic Tire		
							Tilt Angle		Load Cap.	Tilt Angle		Load Cap.
							FWD	BWD	LC 500mm	FWD	BWD	LC 500mm
mm	mm	mm	mm	mm	mm	deg	deg	kg	deg	deg	kg	
STD	3,000	2,000	4,050	3,605	135	135	5	7	2,000			
	3,300	2,150	4,350	3,905	135	135	5	7	2,000			
	3,500	2,250	4,550	4,								

MAIN SPECIFICATIONS

CHARACTERISTICS	1	Manufacturer		DOOSAN	DOOSAN	DOOSAN	DOOSAN	DOOSAN		
	2	Model		B15T-7	B18T-7	B18TL-7	B20T-7	B20TL-7		
	3	Load Capacity	at rated load center	kg	1,500	1,750	1,750	2,000	2,000	
	4	Load Center		mm	500	500	500	500	500	
	5	Power type		AC Electric	AC Electric	AC Electric	AC Electric	AC Electric		
	6	Operator type		Driver Seated	Driver Seated	Driver Seated	Driver Seated	Driver Seated		
	7	Tire type	P= pneumatic, E= solid, C= cushion	E/C	E/C	E/C	E/C	E/C		
	8	Wheels (x = driven)		number of front/rear	x 2/2	x 2/2	x 2/2	x 2/2	x 2/2	
DIMENSIONS	9	Max. Fork Height		with STD 2-stage mast	mm	3,300	3,300	3,300	3,300	3,300
	10	Free Lift		mm	130	130	130	135	135	
	12	Fork carriage		ISO Class	II	II	II	II	II	
	13	Forks		Thickness x Width x Length	mm	35 x 100 x 900	35 x 100 x 900	35 x 100 x 900	40 x 100 x 900	40 x 100 x 900
		Fork Spacing (min. x max.)		mm	240 x 905	240 x 905	240 x 905	240 x 905	240 x 905	
	14	Tilt of Mast		Forward / Backward	deg	5/7	5/7	5/7	5/7	
	15	Length to Fork Face		mm	1,891	1,991	2,132	2,029	2,137	
	16	Overall Width		mm	1,090	1,090	1,090	1,119	1,119	
		Mast Lowered Height		mm	2,150	2,150	2,150	2,150	2,150	
		Mast Extended Height		mm	4,345	4,345	4,345	4,350	4,350	
		Overhead Guard Height		mm	2,010	2,010	2,010	2,010	2,010	
Seat Height		mm	919	919	919	919	919			
21a	Outer Turning Radius		mm	1,515	1,615	1,756	1,648	1,756		
21b	Inner Turning Radius		mm	-	-	-	-	-		
22	Load Moment Center		Center of drive axle to fork face	mm	376	376	376	381	381	
23	Right Angle Stacking Aisle Width (with Pallets & Clearance)		Pallet 1000 x 1200 crossways	mm	3,216	3,316	3,457	3,354	3,462	
	Pallet 800 x 1200 lengthways		mm	3,341	3,441	3,582	3,479	3,587		
	Travel		Loaded / Unloaded	km/h	17/17	17/17	17/17	17/17	17/17	
PERFORMANCE	24	Speed		Lifting	Loaded / Unloaded	mm/s	400/600	400/600	400/600	400/600
		Lowering		Loaded / Unloaded	mm/s	500/450	500/450	500/450	500/450	500/450
		Max. Drawbar pull		Loaded at 1.6 km/h	kg	1,300	1,300	1,300	1,300	1,300
30	Max. Gradeability		Loaded at 1.6 km/h	%	26	25	25	24	24	
WEIGHT	32	Total weight		with min. weight of battery	kg	3,028	3,142	3,333	3,472	3,333
	33	Axle Load		Loaded, Front / Rear	kg	3,988/540	4,358/534	4,372/712	4,841/631	4,769/564
		Unloaded, Front / Rear		kg	1,495/1,533	1,530/1,612	1,635/1,698	1,623/1,849	1,635/1,698	
CHASSIS	35	Number of Wheels (Front/Rear)				2/2	2/2	2/2	2/2	2/2
	36	Tires		Size	Front	18x7-8 (1)	18x7-8 (1)	18x7-8 (1)	200x50-10 (1)	200x50-10 (1)
		Rear		15x4.5-8 (2)	15x4.5-8 (2)	15x4.5-8 (2)	16x6-8 (2)	16x6-8 (2)		
	38	Wheel Base		Distance	mm	1,323	1,423	1,554	1,495	1,495
		Tread Width		Front	mm	902	902	902	912	912
	40	Ground clearance		Rear	mm	167	167	167	201	201
		Loaded		at lowest	mm	86	86	86	86	86
41	at center of wheel base		mm	100	100	100	100	100		
42	Brakes		Service	hydraulic	hydraulic	hydraulic	hydraulic	hydraulic		
	Parking		auto-electric	auto-electric	auto-electric	auto-electric	auto-electric			
POWER TRAIN	45	Battery		Type	lead-acid	lead-acid	lead-acid	lead-acid	lead-acid	
		Voltage		V	48	48	48	48	48	
		Capacity (5 Hours Rating)	Normal	BS type	AH	460	630	690	630	690
				DIN type	AH	460	525	690	575	690
			Max.	BS type	AH	500	750	860	750	860
		DIN type		AH	500	625	750	625	750	
		Battery compartment sizes (W x L x H)		Normal	mm	528 x 992 x 698	638 x 992 x 698	746 x 992 x 698	638 x 992 x 698	746 x 992 x 698
		BS Type		mm	528 x 992 x 698	638 (608) x 992 x 698 (3)	-	638 (608) x 992 x 698 (3)	-	
		Max.		DIN Type	mm	528 x 992 (842) x 698 (4)	638 x 992 (842) x 698 (4)	746 x 992 (842) x 698 (4)	638 x 992 (842) x 698 (4)	746 x 992 (842) x 698 (4)
		Min. Weight		kg	700	800	1,000	1,000	1,000	
47	Electric Motors		Drive motor rating at S2 60 minute	kW	6.0 x 2	6.0 x 2	6.0 x 2	6.0 x 2	6.0 x 2	
48	Lifting motor rating at S3 15%		kW	14	14	14	14	14		
54	Control Type		Drive and Hydraulic	type	MOSFET inverter	MOSFET inverter	MOSFET inverter	MOSFET inverter	MOSFET inverter	
55	Drive Axle		Brake type	type	ODB	ODB	ODB	ODB	ODB	
	Relief Pressure		System	kpa	17,600	19,900	19,900	21,600	21,600	
Attachment		kpa	14,000	14,000	14,000	14,000	14,000			

(1) optional: cushion Tires 18x7 - 12.12 (3) if the operator uses a BS Type Battery (608mm length/575, 630, 690AH/5h capacity), a special accessory (stopper) should be chosen.
 (2) optional: cushion Tires 15 x 6 - 11.25 (4) if the operator uses a DIN Type Battery (842mm width), a special accessory (bracket) should be chosen.

DOOSAN	DOOSAN	DOOSAN
B16X-7	B18X-7	B20X-7
1,600	1,800	2,000
500	500	500
AC Electric	AC Electric	AC Electric
Driver Seated	Driver Seated	Driver Seated
P/E	E	E
x 2/2	x 2/2	x 2/2
3,300	3,300	3,300
130	130	135
II	II	II
35 x 100 x 900	35 x 100 x 900	40 x 100 x 900
240 x 905	240 x 905	240 x 905
5/7	5/7	5/7
2,120	2,120	2,125
1,090	1,119	1,119
2,150	2,150	2,150
4,345	4,345	4,350
2,010	2,010	2,010
919	919	919
1,886	1,886	1,886
494	496	496
376	376	381
3,466	3,466	3,471
3,662	3,662	3,667
17/17	17/17	17/17
400/600	400/600	400/600
500/450	500/450	500/450
1,300	1,300	1,300
26	25	24
3,189	3,281	3,461
4,235/553	4,551/530	4,871/590
1,698/1491	1,696/1585	1,692/1769
2/2	2/2	2/2
18x7-8 (5)	200x50-10	200x50-10
16x6-8 (6)	16x6-8	16x6-8
1,495	1,495	1,495
902	912	912
890	890	890
86	86	86
100	100	100
hydraulic	hydraulic	hydraulic
auto-electric	auto-electric	auto-electric
lead-acid	lead-acid	lead-acid
48	48	48
585	585	585
575	575	575
690	690	690
625	625	625
638 x 992 x 698	638 x 992 x 698	638 x 992 x 698
638 (608) x 992 x 698 (3)	638 (608) x 992 x 698 (3)	638 (608) x 992 x 698 (3)
638 x 992 (842) x 698 (4)	638 x 992 (842) x 698 (4)	638 x 992 (842) x 698 (4)
1,050	1,050	1,050
6.0 x 2	6.0 x 2	6.0 x 2
14	14	14
MOSFET inverter	MOSFET inverter	MOSFET inverter
ODB	ODB	ODB
19,900	19,900	21,600
14,000	14,000	14,000

(5) optional: pneumatic Tires (6) optional: pneumatic Tires

DIMENSIONAL DRAWING - 3-wheel

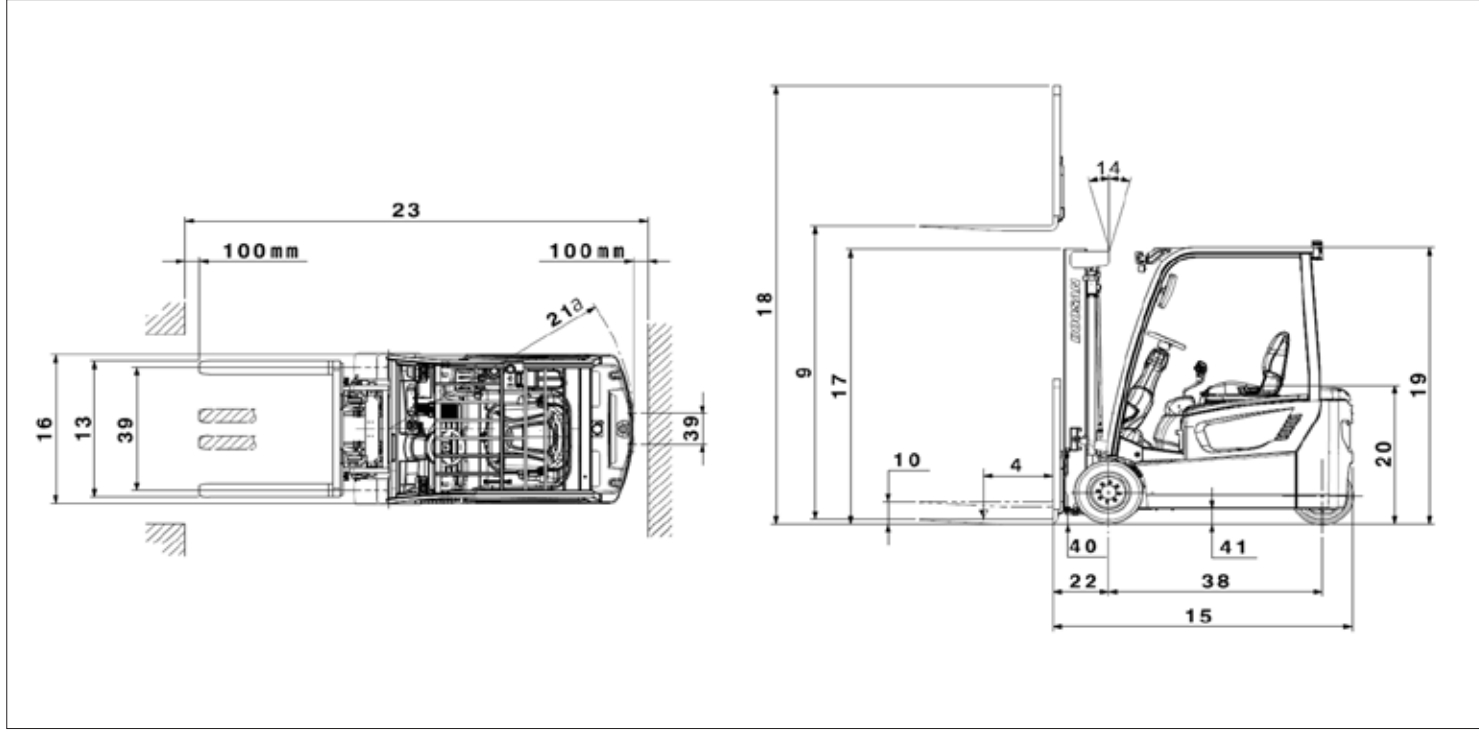

DIMENSIONAL DRAWING - 4-wheel

