

ACCESS WITH ZOOMLION GREEN

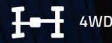

NEW ELECTRIC ZT22JE/ZT26JE

Comply with CE/ANSI/CSA Standard

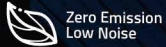

HIGHLIGHTS

- ▶ Customized lithium-ion battery features green, environmental protection, lownoise and zero-emission, ideal for construction and plant maintenance.
- ▶ 460Ah lithium-ion batteries combined with excellent energy management system provide longer running time.
- ▶ Low-temperature regenerative current control and power self-adaptive control effectively improve the safety of Li-ion battery and greatly prolong the batteries service life of at least 10%.
- ▶ Provide a variety of standard charging plugs and 10A/ 16A/ 32A multi-power optional charging mode featuring strong charging adaptability.
- ▶ Brand-new appearance with lightweight GFRP composite material hood and integrally formed coating features anti-corrosion, heat preservation, aging resistance and easy cleaning.
- ▶ Assembled large-opening component box, open-close hood, and a variety of reserved inspection holes easy to service.
- ▶ Accurate and efficient traveling AC drive system provides strong power and stable control. Gradeability reaches 45% and motor is maintenance-free for its lifetime.

FEATURES

Standard Features

Horn	Auto-leveling system
Proportional control	On-board diagnostic system
All motion alarm	Tilt protection system
Flashing beacon	Oscillating axle
Self-closing entry gate	Load sensing system
Emergency descent system	4.3' Led display
Emergency stop button	Swing-out engine tray

Accessories & Options

- ▶ Platform work light
- ▶ Secondary guarding system
- ▶ AC power to platform

ZOOMLION

ELECTRIC TELESCOPIC BOOM LIFTS

NEW ELECTRIC ZT22JE/ZT26JE
Comply with CE/ANSI/CSA Standard

Model	ZT26JE		ZT22JE	
Size				
	Metric	Imperial	Metric	Imperial
Work Height	28.70m	94ft 2in	24.40m	80ft 1in
Platform Height	26.70m	87ft 7in	22.40m	73ft 6in
Horizontal Outreach	22.1m	82ft 6in	17.9m	58ft 9in
A - Stowed Length	11.91m	39ft 1in	10.3m	33ft 10in
B - Stowed Width	2.49m	8ft 2in	2.49m	8ft 2in
C - Stowed Height	2.82m	9ft 3in	2.76m	9ft 1in
D - Platform Length	2.44m	8ft	2.44m	8ft
E - Platform Width	0.91m	3ft	0.91m	3ft
F - Wheelbase	2.80m	9ft 2in	2.52m	8ft 3in
Tread	2.1m	6ft 11in	2.13m	6ft 12in
G - Ground Clearance	0.41m	1ft 4in	0.41m	1ft 4in
Performance				
Platform Capacity (Unrestricted/Restricted)	300/454kg	660/1000lb	300/454kg	660/1000lb
Drive Speed (Stowed)	5.5km/h	3.42mph	5.5km/h	3.42mph
Gradeability	45% (24°)		45% (24°)	
Turning Radius (Inside)	3.11m	10ft 2in	2.72m	8ft 11in
Turning Radius (Outside)	6.16m	20ft 3in	5.58m	18ft 4in
Turntable Swing	360° continuous		360° continuous	
Platform Rotation	±90°		±90°	
Tail Swing	1.61m	5ft 3in	1.61m	5ft 3in
Jib Rotation	130° (-55°~75°)		130° (-55°~75°)	
Max. Wind Speed	12.5m/s	28mph	12.5m/s	28mph
Power				
Battery	80V/460Ah		80V/460Ah	
Charger	6KW/80V		5KW/80V	
Drive Motor	5.2KW		4.2KW	
Lifting Motor	30KW		21KW	
Auxiliary Power	12V DC		12V DC	
Hydraulic Tank	120L	32 US gal	120L	32 US gal
Tire				
Type	15-625 Foam-filled tire		355/55D-625 Foam-filled tire	
Weight				
Gross	17900kg	39462lb	13200kg	29101lb

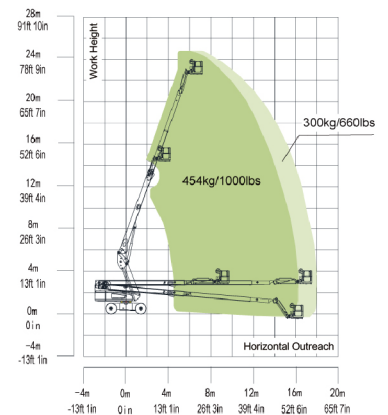
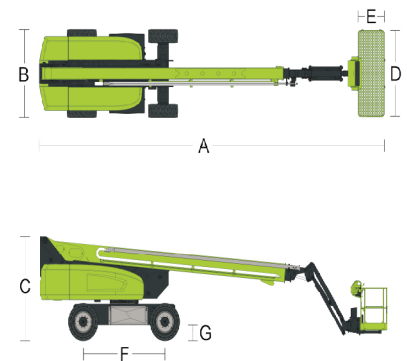

Range of Motion ZT22JE

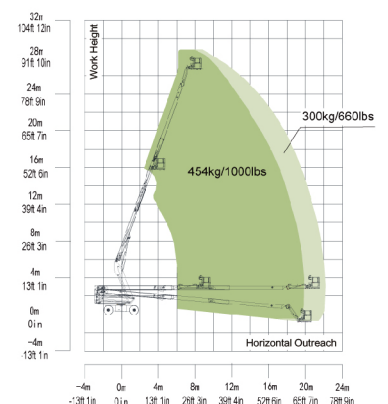

Range of Motion ZT26JE

ZOOMLION ACCESS reserves the right to make specification and/or equipment changes without prior notification.